

Location: _____



T1400-SD

T1400-SD - 8" DEEP POLYPROPYLENE BODY SLOT DRAIN WITH 1/2" ADA COMPLIANT SLOT OPENINGS

Specification: MIFAB® Series T1400-SD, 39.40" long (or length as needed), 13 3/8" deep, 4" internal body width, neutral sloped slot drain system. Body is manufactured from polypropylene. Each body has six tabs, 18" apart, for #3 rebar tie down and leveling. Bodies have flanged ends and a radiused bottom for efficient liquid drainage. Complete with 1/2" wide (ADA compliant) slot opening top assembly for surface drainage. The slot opening top assembly is manufactured from 14 gauge steel and finished with an acid resistant powder epoxy coating. The slot opening top assembly is finished with an acid resistant powder epoxy coating. Specify -.250 for 1/4" wide slot opening. Specify -3 for a fabricated Type 304 stainless steel slot opening top assembly. End and bottom outlets are available in 2" no hub connections. Catch basins are also available.

Function: Typically used in areas where the appearance of grates is not preferred. The discreet slot opening in the top of the T1400-SD drain provides adequate surface drainage while maintaining a discreet appearance.

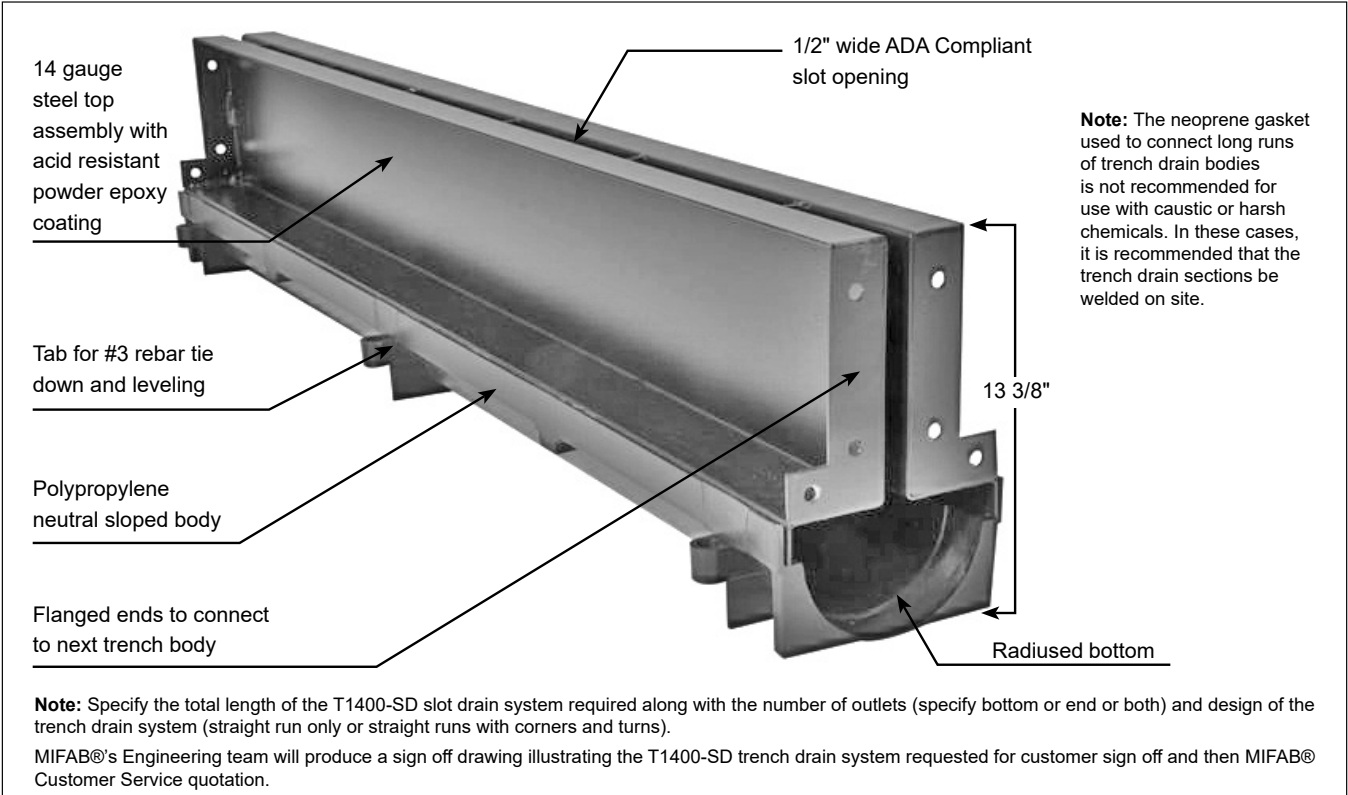

Note: The neoprene gasket used to connect long runs of trench drain bodies is not recommended for use with caustic or harsh chemicals. In these cases, it is recommended that the trench drain sections be welded on site.

End caps / Outlets	
Suffix	Description
-BA	Buy American Act compliant product
-PA	Pennsylvania Steel Act compliant product
-7MG	MI-GARD trap seal protection device (available for 1-1/2", 2", 3", 3-1/2", 4" and 6" outlet connections)
-PEC	Closed end cap
-PEO	2" no hub end outlet
-PBO	2" no hub bottom outlet
Accessories and 45 and 90 Degree Fabrications	
-45	45 Degree Body Section
-90	90 Degree Body Section
-250	1/4" wide heel proof slots in top assembly
-750	3/4" wide heel proof slots in top assembly
Frame Options	
-3	Type 304 Stainless Steel Frame with 1/2" wide slot
-EXT4	4" High extension to the top slot assembly

CALIFORNIA PROPOSITION 65 WARNING. This product contains chemicals known to the State of California to cause cancer and birth defects or other reproductive harm.

Job Name: _____ Page No: _____

Section No: _____ Contractor: _____

Schedule No: _____ Purchase Order No: _____