

Stainless Steel Mesh Grate to suit 4" clear opening channels

Specification: T100-PGA-3-SM stainless steel mesh grates are independently certified to meet Load Class A tested in accordance with EN 1433 (3,372 lbs (15kN)). The grate length is 39.37" (1m). The grates utilize the patented "Clipfix" grate locking mechanism. The system (channel and grate) provides longitudinal shift protection. Optional .5 m grates are also available in Load Class A (Part # T100-PGA-3-SM-500).

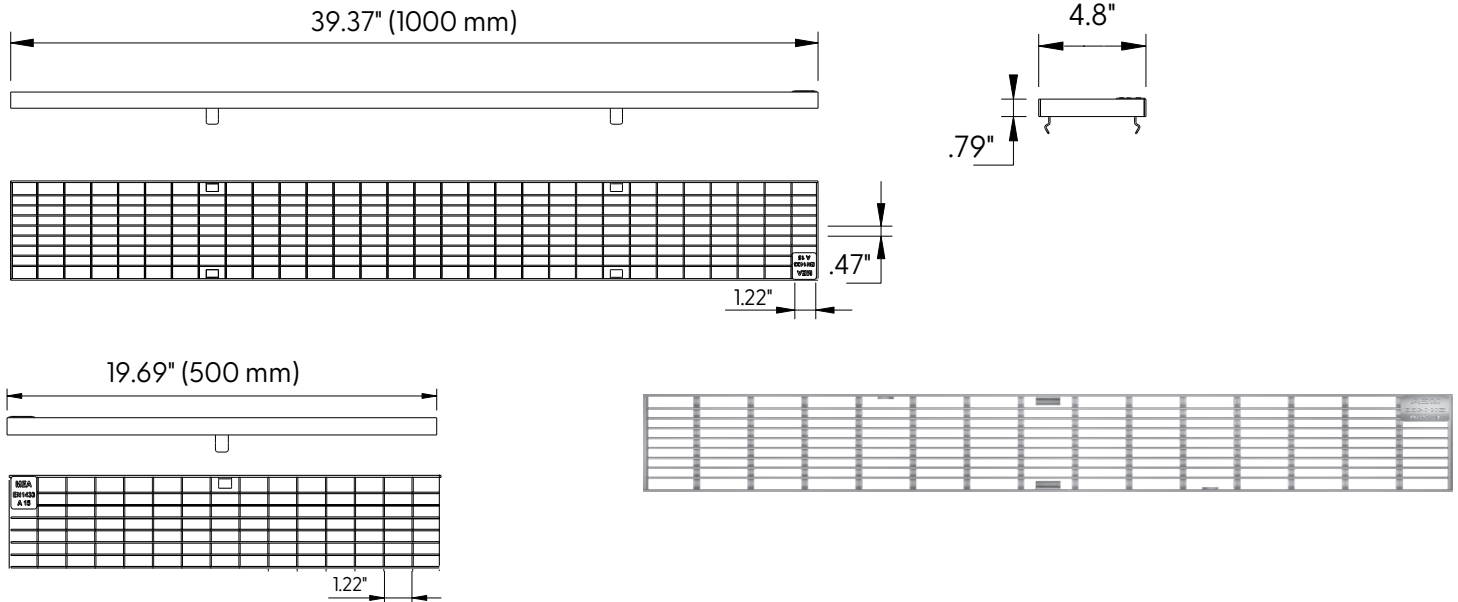

CLIPFIX ADVANTAGE

The MEA polymer concrete and GRP channels are designed for our universal CLIPFIX grate locking mechanism. The system (channel and grate) provides longitudinal shift protection.

LOAD CLASS A



EN 1433 - 3,372 LBS.,
15kN, 70 PSI

Compliance



ADA

GRATE MODEL NUMBER	LENGTH	MATERIAL
T100-PGA-3-SM (TP100-PGA-3-SM)	39.37" (1000 mm)	Stainless Steel Mesh Grate
T100-PGA-3-SM-500 (TP100-PGA-3-SM-500)	19.69" (500 mm)	Stainless Steel Mesh Grate

*For plastic channel use TP100-PGA-3-SM or TP100-PGA-3-SM-500

NOTES:

Revision Date: 08/11/2021

CALIFORNIA PROPOSITION 65 WARNING. This product contains chemicals known to the State of California to cause cancer and birth defects or other reproductive harm.

MIFAB reserves the right to make changes in material and design without formal notice and obligation. USA: 1-800-465-2736 www.mifab.com CAN: 1-800-387-3880