



CERTIFIED
MANAGEMENT SYSTEM
ISO 9001:2015

Cable

Go to
www.mifab.com
for the most
current product
specification
sheets.



Installation Instructions
Industrial Heating Cable Products
LIT-097

IMPORTANT GENERAL INSTRUCTIONS

These instructions are to be followed when installing MIFAB® Heating cables on pipes in ordinary locations. Consult factory for installation of braided cable in hazardous locations. MIFAB® has four basic types of heating cables: Self-Regulating, Constant Wattage, Mineral Insulated and Series Long Line Cable. Although they are all resistance type cables, they each have different operating characteristics. These characteristics may make one type of cable more suitable for a particular application than another. This manual, however, is not intended as a product selection manual. Refer to MIFAB® Design Guide for Heat Tracing Products™ for product selection guidelines. Below is a chart highlighting certain characteristics for MIFAB® heating cables.

1. Open package and visually check for breaks or nicks in the cable jacket. File claim with carrier if any damage is found.
2. Never energize the cable when it's coiled or on a reel. Test only when it is laid out straight.
3. After removing the cable from the carton or wrapping, check the resistance of the unit from buss wires to braid or metal sheath with a 500 VDC (1,000 VDC recommended) megger to assure the cables have not been damaged during shipping and handling. If the cable has no braid or metal sheath, uncoil the cable onto a metal surface and check resistance between the buss wires and the metal surface. See table on page 9 for acceptable minimum insulation resistance readings.

WARNING

ELECTRIC SHOCK HAZARD. Any cable with an insulation resistance reading less than 10 megohms before installation should not be installed. Contact your local MIFAB® representative.

4. The heating cables should be stored in their shipping cartons or on reels in a dry atmosphere until they are ready to be installed.
5. Handle coils and reels utilizing equipment designed for that purpose.
6. Do not drop coils or reels, especially from transporting equipment.
7. Lift or handle reels so that the lifting/handling device does not come in contact with the cable or its protective covering. Coils should be placed on a skid.
8. Handle reels so that the deterioration or physical damage of cable is prevented.

NOTICE**STORE IN DRY AREA**

These products may become damaged by moisture. Damage to electrical components, electrical properties, corrosion or other damage may occur if equipment is not stored in a dry location. Visual inspection and electrical checks must be performed prior to installation to ensure safety and proper operation. See equipment installation manual or contact the factory for more information. 1-800-465-2736 or www.mifab.com.

MIFAB® CABLE TYPES

	Self-Regulating	Constant Wattage	Mineral Insulated	Series Long Line
Hazardous ratings available	Yes	Yes	Yes	Yes
Usable on plastic pipe	Yes*	No	No	No
Can be cut to length in field	Yes	Yes	No	Yes
Can be single overlapped	Yes	No	No	No

* SRL only on plastic pipe.

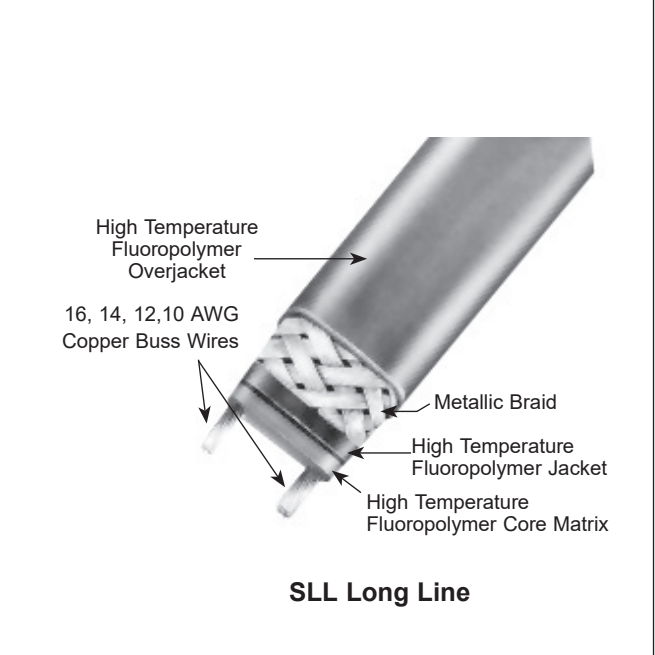
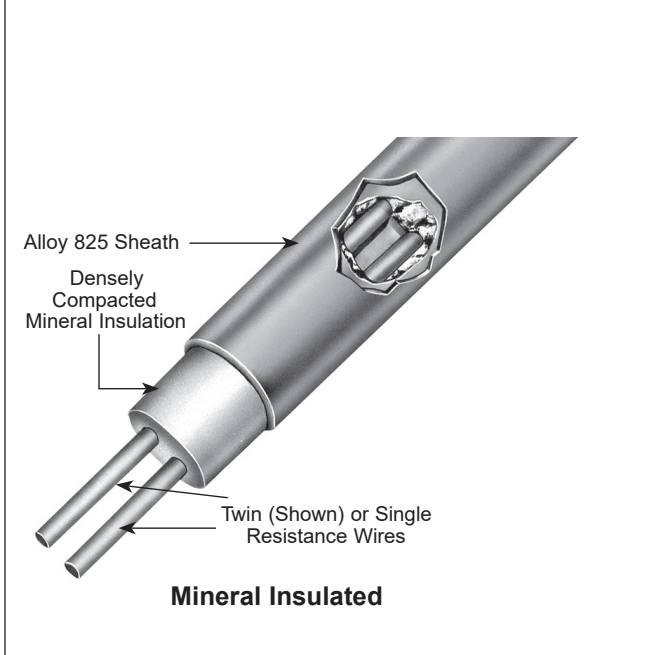
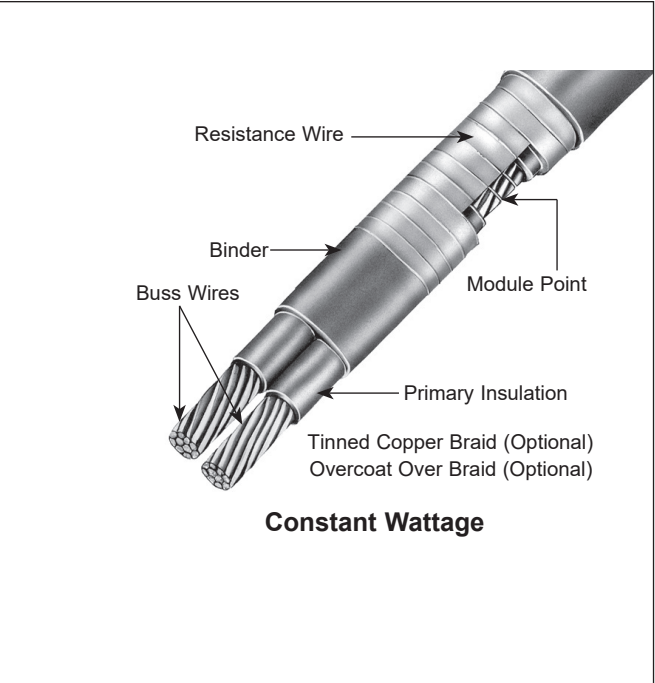
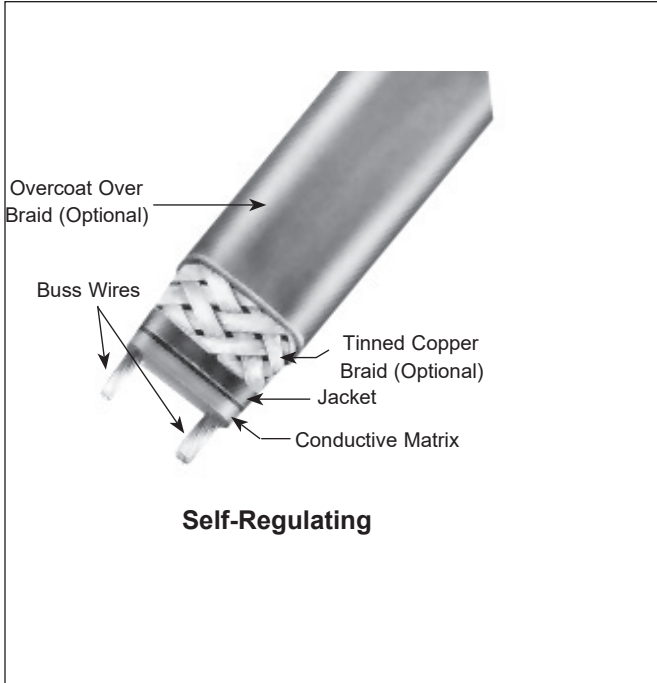

INSTALLATION**A. IMPORTANT — GENERAL NOTES REGARDING INSTALLATION OF HEAT TRACING SYSTEMS.****WARNING****A. FIRE HAZARD. Failure to follow these guidelines could result in property damage or personal injury.**

1. Read this instruction sheet and those enclosed with the accessories to familiarize yourself with the products.
2. Selection of heating cable type and rating should be in accordance with the procedures located in the “MIFAB® Design Guide for Heat Tracing Products”.
3. Ensure all pipes, tanks etc. have been hydrostatically tested prior to the installation of the heating cable.
4. Always install tracing at the 5 or 7 o'clock position on a pipe.
5. Installation Guidelines for fire protection systems:
 - a. For use on insulated UL listed steel schedules 5, 10, 20 and 40 standpipe and sprinkler system pipe up to and including 6 in. size. Includes use on elbows, tees, flanges, hangers and valves as shown. (show figures of heating cable installed to various equipment as mentioned above). UL listed fiberglass insulation with a minimum k-factor of 0.25 BTU/hr °F/ft² -in with weatherproof cladding must be used.
 - b. For systems having piping which connects between buildings in unheated areas, coolers and freezers.
 - c. For systems having sprinkler piping that is installed in coolers or freezers where the temperature is -40°F or greater.

Not intended to be used as the means to prevent freezing of sprinkler branch lines including all accessories for these lines and automatic (deluge, preaction, dry pipe, alarm, etc.) valves as referenced in NFPA 13.

For use in Ordinary Hazard Occupancies only as specified in NFPA 13 the standard for the installation of sprinkler systems. Fire suppression system heater circuits must be connected to monitoring equipment. A listed power supply relay with the appropriate voltage coil shall be connected in parallel prior to the heat tracing (should show figure with typical installation). The output contacts of the listed power supervisory relay should be connected to a listed fire control panel which has provisions for supervisory circuits.

6. Do not attempt to heat trace any piece of equipment which will not be insulated.
7. Do not install heating cable on equipment which could become hotter than the heating cable's maximum exposure temperature.
8. Do not install heating cable in an area or on equipment which contains potentially corrosive materials without having a suitable protective jacket on the cable.
9. The minimum bending radius for all MIFAB® heating cables is six times the minor diameter.
10. Allow a minimum of 2" between cable runs.
11. Always install heat tracing on the outside radius of elbows.
12. Never install heat tracing over expansion joints without leaving slack in the cable.
13. Never use tie-wire or pipe straps to secure Self-Regulating Maximum Circuit length or Constant Wattage heating cables.
14. Observe all published specifications. Do not expose cables to temperatures above their specified maximums. Do not run cables longer than specified maximum circuit lengths. See table 3 for details.
15. Pumps and small vessels should be heat traced and controlled with the piping on the inflow end. The cable on the pump or vessel should be physically separate to permit disconnection during maintenance or removal.
16. Use aluminum foil tape to cover the heating cable whenever the cable is not in good contact with the pipe

(i.e. at supports, valves, pumps, etc.) or whenever its use is specified by the “MIFAB® Design Guide for Heat Tracing Products”.

17. Separately controlled circuits should be provided on dead end legs and closed bypasses.
18. No heat tracing circuit should extend more than two feet beyond a point where two or more pipes join when such junctions permit optional flow paths. In such cases, separately controlled traces should be used.
19. The minimum installation temperature for all MIFAB® heating cables is -76°F (-60°C).
20. MIFAB® Type SRL heating cables are well suited for heat tracing plastic pipes. Consult “MIFAB® Design Guide for Heat Tracing Products” for design recommendations. Installation details AD1 through AD17 apply for plastic pipe only when Type SRL heating cable is used. Consult factory for applications involving other products.

B. INSTALLING A SINGLE RUN OF CABLE ON A PIPE.

1. Mount the reel of cable on a holder and place near one end of the pipe run to be traced. Choose the end from which it will be the easiest to pay out the cable.
2. Pay out the cable from the reel and loosely string along the piping, making sure the cable is always next to the pipe when crossing obstacles. For example, if the heater is on the wrong side of a crossing pipe, you will have to restring the cable or cut and splice it.

CAUTION

To prevent damage to cable, avoid such things as:

- Pulling the cable over sharp edges.
 - Forcibly pulling the cable free if it snags while being paid out.
 - Allowing the cable to be walked on or subjected to other abuse which could cause mechanical damage.
3. When you reach the end of the circuit, secure the heater cable to the pipe using glass tape or plastic cable tie with a temperature rating compatible with the heater cable. If this end is to have an end seal installed, remember to leave about a foot of extra cable. If it is a power connection, leave about two feet of extra heater cable.
 4. (If the heater cable is to be spiralled, go to step 4A.) Begin attaching the cable to the pipe about every foot (.3 meters). Place the cable on the bottom half of the pipe at the 5 or 7 o'clock position. Refer to installation detail AD1. Go to step 5.
 - a. Note the path of the heater cable and the spiral factor of the design. A simple way to think about spiral factor is: A1.1 spiral factor means install 11 feet of heating cable on every 10 feet of pipe, etc. At about every 10 feet of pipe, pull the required amount of cable and let hang in a loop, and attach the cable to the pipe.
 - b. Rotate the loops around the pipe until all the slack has been taken up. Even out the spirals of the heater cable and secure to the pipe as necessary to obtain good contact. The entire circuit can be installed with hanging loops with the spiralling on the pipe being done when you trace the heat sinks. Refer to installation detail AD3.
 5. At a heat sink (pipe supports, valves, pumps, reducers, gauges, bucket strainers, etc.), attach the heater cable to the pipe just before the heat sink. Refer to the design specs to determine the amount of heater cable you need to install on the heat sink. Pull this amount of cable into a loop, attach the heater cable on the other side of the heat sink and continue attaching the cable down the pipe as before.
 6. When you reach the heater cable reel, you should have the heater cable attached all along the pipe, with the correct amount of heater cable pulled in loops at all heat sinks. Attach the cable to the pipe, (leave an extra foot if at an end seal, two feet if at a power connection) and cut the heater cable from the reel.
 7. Install the heater cable loops on the heat sinks. Refer to the proper installation detail (AD5-AD12) for a

Design and dimensions are subject to modification. Prices do not include applicable taxes. Visit www.mifab.com for the most recent product information.

general idea of how to install the cable, but remember:

- It is important to get the proper amount of heater cable on the heat sink, rather than exactly as the detail shows. The detail is just a guide.
- Self-Regulating heater cables are very flexible and can be single overlapped for installation ease. Feel free to use this feature when you can.

WARNING

FIRE HAZARD. Do not overlap constant wattage or mineral insulated heating cables.

- By having the cable installed this way, it can be removed easily from the heat sink without cutting if access to, or removal of the heat sink is required.

Note: If a tee is designed into the system, or if you are using two or more short cable lengths to complete a circuit, allow two or three feet of each cable to overlap. This will allow flexibility in assembling the connection kit and locating it on the pipe.

C. INSTALLING MORE THAN ONE HEATING CABLE ON A PIPE.

There are two cases where you will need to install more than one heater cable on a pipe:

- When the design calls for more than one cable.
- When the lines being heat traced are considered important enough to install a backup (redundant) heat tracing system.

The installation requirements are different for these cases.

1. Installing multiple heater cables for design requirements.

The most common multiple cable requirement is two cables on a pipe. Below are the recommended techniques for the two cable systems. They also apply to installations where three or more cables are to be installed on a pipe. There are two ways of paying out two heater cables along a pipe. The first is to locate two reels of heater cable and supply one cable from each. This method works for all types of piping runs.

However, it may increase material waste by leaving unusable lengths from two reels. The second way is to supply both cables from one reel. This method is generally the easiest for relatively straight, simple piping runs. For each circuit, decide which method to use and then go to the appropriate part below.

a. Supplying cable from two reels.

The general procedure here is the same as given earlier, but there are a few things to do to make sure the system is correctly done.

- i. At each heat sink, the easiest thing to do is supply the extra heater called for by the design drawing from only one heater cable. This avoids having to measure out half of the requirement from each cable.
- ii. When doing the previous step, leave a small loop other cable at equipment which may be serviced, such as pumps, valves, instruments, etc. This is so both heater cables may be removed enough for future access.

b. Supply heater cables from one reel.

The general procedure is the same as given earlier, but there are a few things to do to make sure the system is correctly done.

- i. With this method, a loop is pulled for the entire circuit. To do this, attach the end of the heater cable to the pipe near the heater cable reel. Remember to leave enough extra cable for the type of connection to be installed.
- ii. Begin pulling the cable off the reel in a large loop down the piping run. Be sure to keep the cable next to the pipe. Moving down the run, continue attaching the cable to the pipe, leaving the side of the loop going back to the reel unattached.

- iii. You will want both sides of the loop to be about the same length to avoid future problems. Also, it is easier to install the extra cable required at each heat sink from only one cable. Therefore, pull the right amount of extra heater cable needed at every second heat sink from the side of the loop you are attaching to the pipe. At the remaining serviceable heat sinks (pumps, valves, instruments, etc.) don't forget to leave a short loop of cable for slack when access to the equipment is needed.
- iv. When the end of the piping run is reached, pull the proper amount of extra cable for the connection to be installed.
- v. Now, begin working the remaining side of the loop back toward the reel, installing it on the pipe and heat sinks as required.

2. Installation for Backup (Redundant) Systems.

The purpose of a backup system is to provide the proper amount of heat from the second heater cable if there are problems with the first. Therefore, each cable must be installed so it can do the job alone. The simplest way to do this is to install the first heater cable as given in Section B. Then, go back and install the backup heater cable the same way.

There are several things to keep in mind:

- The power connections and end seals for the two cables are often designed to be at opposite ends of the run in a redundant system. Remember to leave the proper amount of extra cable for the connection to be installed on each cable at that end.
- On piping one inch IPS or smaller, it can be difficult to apply both heater cables with good contact at all places. The main thing is to get the correct amount of cable installed. However, try to get as much contact with the piping and heat sinks from both cables as possible.

Supplementary Instructions for ATEX and IECEx Applications SRL and SRM/E Self-Regulating Heating Cables, U Series Connection Accessories Type UPC, UMC, UES and RTES

1. Do not bend the cable for a length of 300mm from the cable gland inlet.
2. Connection and termination of Chromalox ATEX and IECEx certified cable must be carried out by using the U Series of certified cable connection kits as supplied by MIFAB®, Inc. These are only to be used for the operations for which they were designed.
3. The supply circuit to the heating cables must be protected by a safety differential device or equivalent ground fault protection.
4. The earthing braid of the heat trace cable must be bonded to a suitable earth terminal.
5. The minimum cable installation temperature for SRL and SRM/E cable is -40°C (-40°F).
6. The certified minimum cable exposure temperature for SRL and SRM/E cable is -60°C (-76°F).

WARNING

ELECTRIC SHOCK HAZARD. Disconnect all power before installing or servicing heating cable. Failure to do so could result in personal injury or property damage. Heaters must be installed by a qualified person in accordance with IEC 62086-2 2001.

Any installation involving electric heating cables must be performed by a qualified person and must be effectively grounded in accordance with IEC 62086-2:2001 to eliminate shock hazard.

TYPICAL INSTALLATION DETAIL

Note: Cable located at nominal 45° below horizontal centerline.

AD1 - One Run of Cable

Note: Cable located at nominal 45° below horizontal centerline on either side.

AD1 - Two Runs of Cable

Note:
1. Do not spiral if ratio of heater length to pipe length is greater than 1.5. Instead, use two cables or choose a higher wattage heater.
2. Refer to pitch chart in design data section on circuit drawing for proper pitch length.

AD3 - One Cable-Spiralling Method

Note: Heating cable is applied to the outside (long) radius of the pipe elbow.

AD4 - One Run of Cable at Pipe Elbow

Note: Insulate over flanges & orifice plate and weatherseal. All piping must be fully insulated and weathersealed.

AD5 - Orifice Flange

Note: All piping must be fully insulated and weathersealed.

AD6 - Expansion Joint

Design and dimensions are subject to modification. Prices do not include applicable taxes. Visit www.mifab.com for the most recent product information.

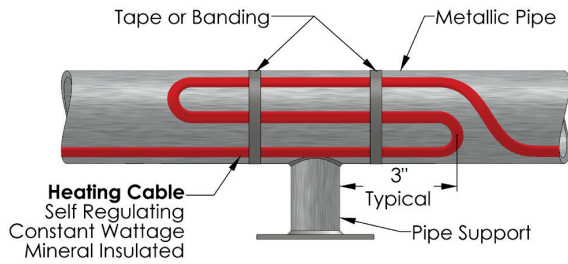

Note: Pipe support to be insulated two feet below pipe and weathersealed. All piping must be fully insulated and weathersealed.

AD7 - Welded Support

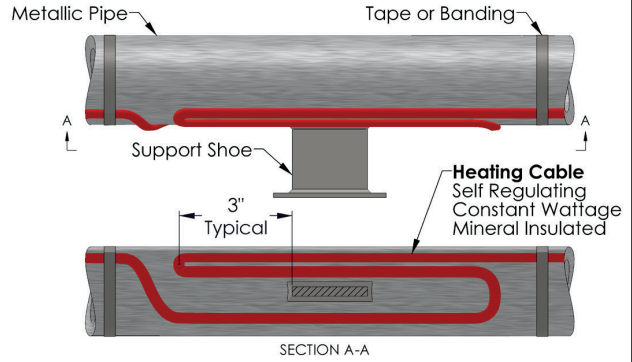

Note: Insulate and weatherseal support. All piping must be fully insulated and weathersealed.

AD8 - Shoe Support

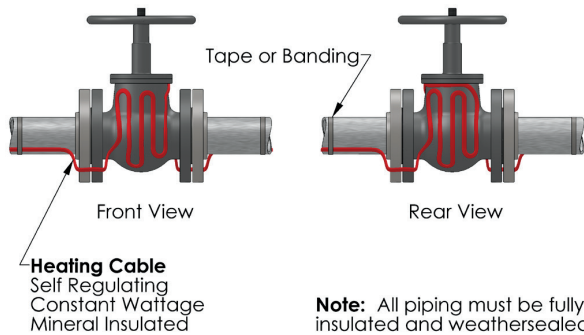

Note: All piping must be fully insulated and weathersealed.

AD9 - Valve

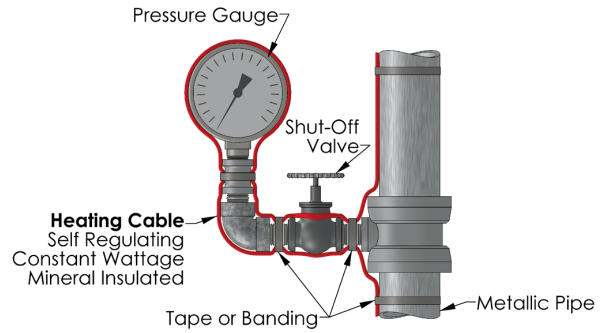

Note: Completely insulate & weatherseal line and gauge. All piping must be fully insulated and weathersealed.

AD10 - Pressure Gauge

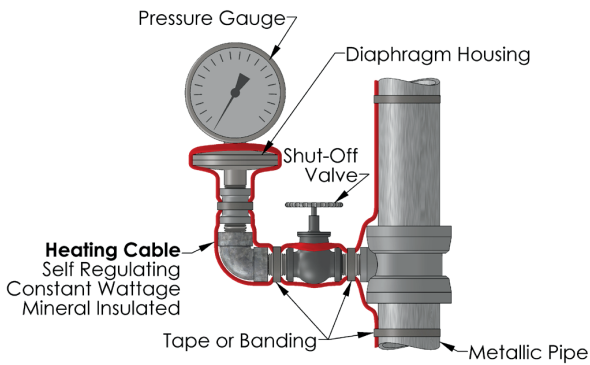

Note: Completely insulate & weatherseal line. All piping must be fully insulated and weathersealed.

AD11 - Diaphragm Pressure Gauge

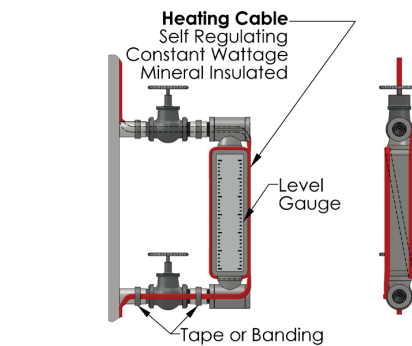

Note: All piping must be fully insulated and weathersealed.

AD12 - Level Gauge

UPC Junction Box Connection
(See Instruction Sheet PJ495 for installation instructions.)

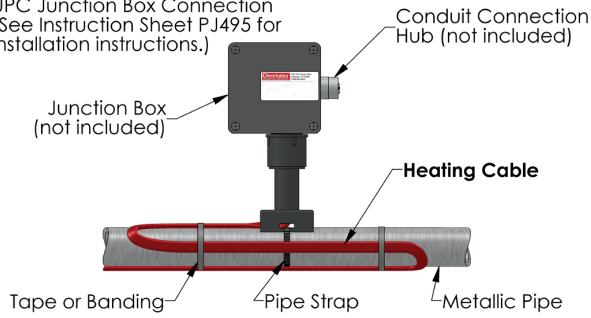

Note: All piping must be fully insulated and weathersealed.

AD13 - U Series Power Connection

Splice or Tee Connection using UMC Kit.
(See Instruction Sheet PJ497 for installation instructions.)

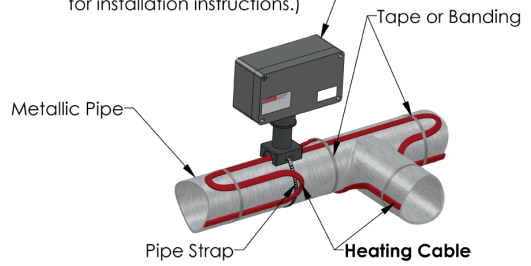

Note: All piping must be fully insulated and weathersealed.

AD14 - U Series Splice & Tee Connection

Splice Connection
(See Instruction Sheets PJ445 or PJ446 for installation instructions.)

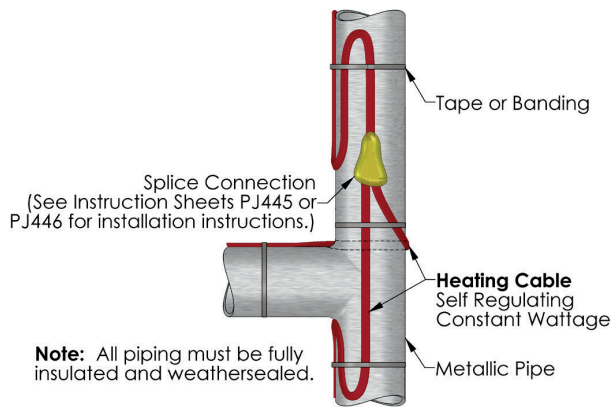

Note: All piping must be fully insulated and weathersealed.

AD14 - EL Series Splice and Tee Kit

End Seal Kit
(See Instruction Sheet PJ450 for installation instructions.)

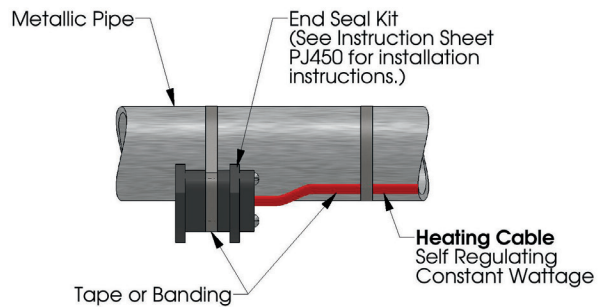

Note: All piping must be fully insulated and weathersealed.

AD15 - End Seal

End Seal Kit
(See Instruction Sheet PJ496 for installation instructions.)

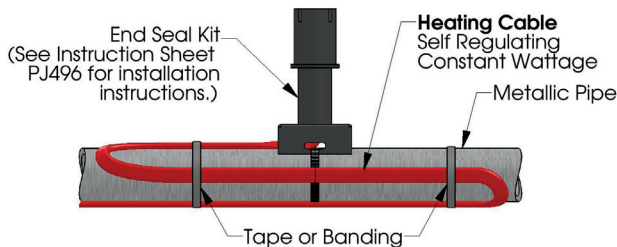

Note: All piping must be fully insulated and weathersealed.

Conduit Connection Hub
(not included)

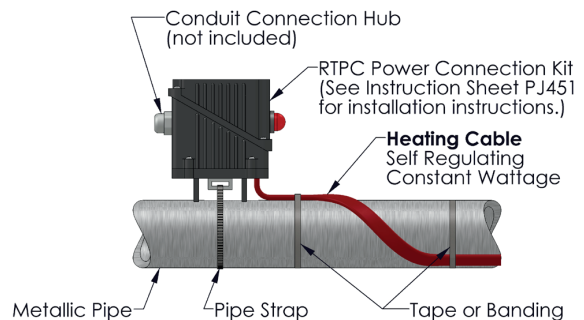

Note: All piping must be fully insulated and weathersealed.

Design and dimensions are subject to modification. Prices do not include applicable taxes. Visit www.mifab.com for the most recent product information.

MIFAB®, Inc., 1321 West 119th Street, Chicago, Illinois 60643-5109, USA
All sales subject to MIFAB's® Terms and Warranties. Please refer to inside front cover.

USA Toll Free: 1-800-465-2736 • Fax: 1-773-341-3049
Canada Toll Free: 1-800-387-3880 • sales@mifab.com

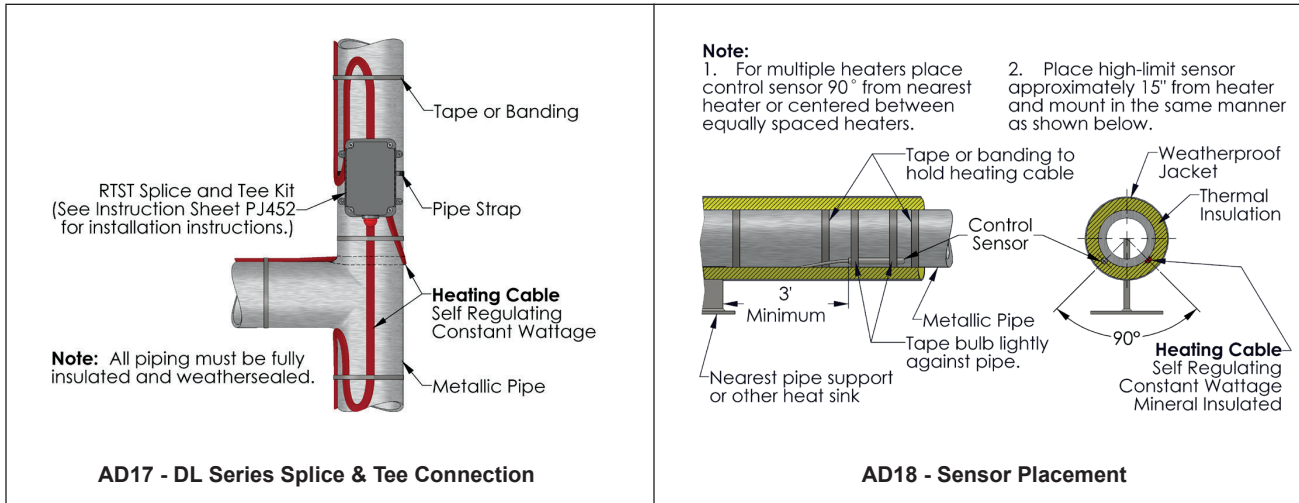

WIRING

WARNING

ELECTRIC SHOCK HAZARD. Disconnect all power before installing or servicing heating cable. Failure to do so could result in personal injury or property damage. Heater must be installed by a qualified person in accordance with the National Electrical Code, NFPA 70.

ELECTRIC SHOCK HAZARD. Any installation involving electric heating cables must be performed by a qualified person and must be effectively grounded in accordance with the National Electrical Code to eliminate shock hazard.

ACCESSORIES:

1. Selection of installation accessories should be in accordance with ChromaTrace 3.0 design software program. Ensure accessories are rated for the area where they are located. If MIFAB® accessories are not used with cable, all third party approvals are voided.
2. Only use MIFAB® installation kits and use them only for the operations for which they are designed.
3. The instructions included in the MIFAB® installation accessories must be followed in order for the third party approvals (UL, FM, CSA, ATEX, IECEx, etc.) to apply.
4. Junction boxes must be in accordance with the requirements of the area classification.
5. All outdoor junction boxes must be located above grade level. Covers should be kept on the boxes at all time when not being worked in.
6. All terminations must be protected from the weather and from physical damage by locating them either under the weatherproof insulation or inside an appropriate junction box.
7. All equipment must be properly grounded.
8. Install installation accessories according to the instructions included in the kits and per installation details AD13 through AD17.

CAUTION

To prevent equipment damage, Circuits fed from overhead lines should be protected by secondary lighting arrestors.

CONTROLS:

1. All heating circuits should have temperature controls. Temperature control of the pipeline can be obtained through various MIFAB® temperature controls.
2. Contactors must be used when load currents exceed the rating of the thermostat contacts. Equipment protection ground fault (30 mA EPD) thermal breakers are recommended with type SRL, SRM/E, SRP & SLL.

- The temperature control should be mounted in a location where it will not be subjected to excessive shock or vibration.
- Line sensing temperature sensors should be mounted in accordance with Installation Detail AD18 (see Detail above).
- Ambient sensing temperature sensors should be located at a point where the lowest ambient temperature is expected.

CAUTION

To prevent equipment damage, handle and secure temperature sensors, especially thermostat bulbs and capillaries with care to avoid distortion or crimping which might impair control accuracy.

- Exposed thermostat capillaries should have mechanical protection.

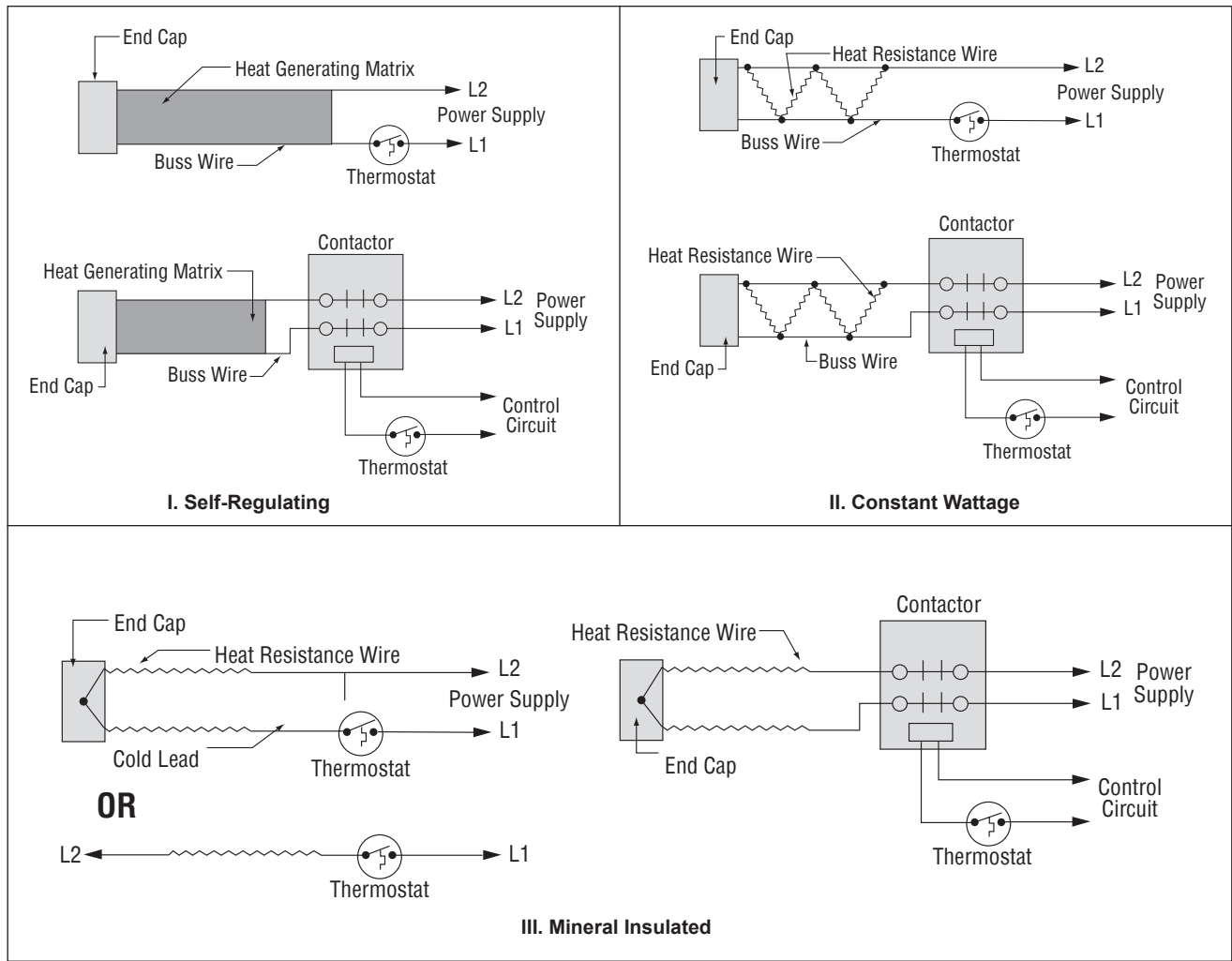

INSTALLATION TESTING

When the heater cable and connections for a circuit have been completed, immediately perform the following checks.

- Visually inspect the heater cable and temperature controls for signs of mechanical damage. If damage is seen, either replace the complete heater cable, or cut out the damaged section and replace using the proper splice connection for the area and cable you are using.
- Inspect all connections to be sure they are correctly assembled. Be sure each heater cable entry to a

connection has a grommet and the compression plates and caps are properly tightened.

3. Inspect the insulation resistance of the circuit using a 500 VDC (1,000 VDC recommended) megger. Always perform this test at the power connection. See the following table for minimum insulation resistance readings. Any cable with an insulation resistance below the recommended value should be removed and factory should be contacted.

	Delivery	Installed	Maintenance
MIFAB® SR	20 MΩ	5 MΩ	5 MΩ
MIFAB® MI	20 MΩ	5 MΩ	5 MΩ
MIFAB® Snow Melt	20 MΩ	5 MΩ	5 MΩ

4. Check voltage at end of circuit and record in log.(See page 14).

THERMAL INSTALLATION

An installed heating circuit should be thermally insulated immediately to provide protection from damage from ongoing work. Things to remember about insulating:

1. Insulate the equipment being heat traced as soon as possible after the heating cable is installed. This will protect the cable from possible physical damage.
2. The type and thickness of thermal insulation specified on the design drawing must be used. If you use another type or thickness, the heater cable type or amount may have to be changed.
3. Never install wet insulation. Both the piping and the insulation must be dry when thermally insulating a circuit. Wet insulation may cause start-up or operational problems.
4. Properly weatherproof the thermal insulation. All places where valve stems, conduits, pipe supports, connection housing, thermal capillary tubes, etc. extend outside the insulation jacketing must be sealed with a suitable compound to keep water out.
5. Insulate valves fully up to, and including, the packing gland.
6. Heat trace and fully insulate the face of all non-diaphragm pressure instruments.
7. Insulation must be covered by a weatherproof barrier, such as an aluminum jacket.
8. If you are using metal jacketing and sheet metal screws, be sure the screws are not long enough to penetrate the thermal insulation and damage the heater cable.
9. Again, perform the megger test on the circuit immediately after the thermal insulation is installed to detect if any mechanical damage may have occurred.
10. When the insulation and the weatherproofing is complete, attach "Electric Traced" labels on the outside of the insulation. These should be installed where they are visible from normal operations, usually on alternating sides about every 10 feet. It is also useful to mark the location of any connections buried under the insulation.

Additional requirements for rigid thermal insulations:

1. In the standard single heater cable installation, rigid insulations do not need to be oversized. However, they should be carved so there is no gap in the insulation.
2. In case of redundant or multiple heater cables, rigid insulations which are .500 inches oversized should be used.

COMMISSION TESTING

1. Again, visually inspect the piping, insulation and connections for the heater cable to make sure no physical damage has occurred if some time period has elapsed since the installation and start-up.
2. Megger the system again to determine if damage not readily visible has occurred.
3. Turn all branch circuit breakers to the OFF position.

For systems controlled by ambient-sensing thermostats:

1. If the actual ambient temperature is higher than the desired thermostat setting, turn the thermostat setting up high enough to turn the system ON or (some models) turn the selector switch to the ON position.
2. Turn the main circuit breaker ON.
3. Turn the branch breakers ON one-by-one until all are on.
4. Allow system to run at least four hours in order to let all pipes reach steady-state.
5. Measure the amperage draw, ambient temperature and pipe temperature for each circuit and record in the installation log. This information may be needed for future maintenance and troubleshooting.
6. When the system is completely checked out, reset the thermostat to the proper temperature.

For systems controlled by line-sensing thermostats:

1. Set the thermostat to the desired control temperature.
2. Turn the main circuit breaker ON.
3. Turn ON the branch circuit breakers controlled by the thermostat.
4. Allow the pipe temperatures to be raised to the control point. This may take up to four hours for most circuits (large full pipes may take longer).
5. Measure the amperage draw, ambient temperature, and pipe temperature for each circuit and record in the installation log.

This information may be needed for future maintenance and troubleshooting.

For redundant systems:

Follow the procedure above for the type of control system you have, but commission the systems one at a time. Start up the primary system, qualify it and shut it down. Then start up the backup system, qualify it and shut it down.

SPECIFICATIONS

Table 1 – Maximum Temperatures

Cable Type	Max. Maintain (Power On)	Max. Exposure (Power Off)
SRL / HSRL	150°F	185°F
SRM/E / HSRM	302°F	420°F
CWM	See table below	See table below
SRF	150°F	185°F
SRP	230°F	275°F
SLL	302°F	450°F

Table 2 – CWM Cable Maximum Maintenance Temperatures

Output (W/Ft.)	Temperatures (°F)								
	3	4	6	6.7	8	9	10.1	10.6	12
w/o AT-1 Tape	340	325	293	282	262	246	229	222	200
w AT-1 Tape	350	344	332	328	320	314	307	304	296

Design and dimensions are subject to modification. Prices do not include applicable taxes. Visit www.mifab.com for the most recent product information.

Table 3 – Maximum
SRL / HSRL Circuit Breaker Selection (Max. Circuit Lengths in Ft.)

Cable Rating	50°F Start-Up (Ft.)						0°F Start-Up (Ft.)						-20°F Start-Up (Ft.)					
	10A	15A	20A	25A	30A	40A	10A	15A	20A	25A	30A	40A	10A	15A	20A	25A	30A	40A
SRL / HSRL3-1C	205	305	360	NR	NR	NR	135	200	270	330	360	NR	120	185	245	300	360	NR
SRL / HSRL3-2C	400	600	660	NR	NR	NR	275	415	555	660	NR	NR	245	370	495	600	660	NR
SRL / HSRL5-1C	125	185	250	270	NR	NR	90	135	180	225	270	NR	80	120	160	205	245	270
SRL / HSRL5-2C	250	375	505	540	NR	NR	180	270	360	450	540	NR	160	245	325	405	490	540
SRL / HSRL8-1C	100	150	200	215	NR	NR	70	110	145	180	215	NR	65	100	130	165	200	210
SRL / HSRL8-2C	185	285	375	420	NR	NR	135	200	265	335	395	420	120	175	235	300	350	420
SRL / HSRL10-1C	60	95	130	160	180	NR	50	80	105	130	155	180	45	70	95	120	140	180
SRL / HSRL10-2C	100	160	210	260	315	360	80	125	170	210	255	340	75	120	160	195	240	320

SRP Circuit Breaker Selection (Max. Circuit Lengths in Ft.)

Cable Rating	50°F Start-Up (Ft.)						0°F Start-Up (Ft.)						-20°F Start-Up (Ft.)					
	15A	20A	30A	40A	50A	40A	15A	20A	30A	40A	50A	40A	15A	20A	30A	40A	50A	40A
SRP 5/1	145	195	295	390	490	NR	110	145	215	295	360	NR	70	90	135	180	225	NR
SRP 10/1	100	135	200	270	330	NR	70	95	145	190	240	NR	65	85	130	175	215	NR
SRP 15/1	75	100	150	200	250	NR	60	80	120	160	200	NR	55	70	110	145	180	270
SRP 5/2	295	385	580	750	750	NR	220	290	430	580	720	NR	135	180	270	360	450	540
SRP 10/2	200	270	400	530	665	NR	145	190	290	380	480	NR	130	175	260	350	440	210
SRP 15/2	150	195	295	390	500	NR	120	160	235	320	400	420	110	145	220	290	360	420

SRM/E / HSRM Circuit Breaker Selection (Max. Circuit Lengths in Ft.)

Cable Rating	50°F Start-Up (Ft.)					0°F Start-Up (Ft.)					-20°F Start-Up (Ft.)				
	15A	20A	30A	40A	50A	15A	20A	30A	40A	50A	15A	20A	30A	40A	50A
SRM/E / HSRM 3-1	285	385	NR	NR	NR	275	375	385	NR	NR	265	365	385	NR	NR
SRM/E / HSRM 3-2	575	770	780	NR	NR	540	750	780	NR	NR	525	740	780	NR	NR
SRM/E / HSRM 5-1	180	240	360	375	NR	165	220	330	375	NR	155	210	310	375	NR
SRM/E / HSRM 5-2	360	480	720	750	NR	325	430	645	750	NR	310	415	620	750	NR
SRM/E / HSRM 8-1	145	190	285	325	NR	135	175	265	325	NR	130	165	250	325	NR
SRM/E / HSRM 8-2	285	380	575	650	NR	255	345	520	650	NR	245	335	490	650	NR
SRM/E / HSRM 10-1	95	125	190	250	NR	90	110	175	250	NR	85	100	170	245	250
SRM/E / HSRM 10-2	190	255	385	490	NR	165	225	345	490	NR	155	215	330	470	490
SRM/E / HSRM 15-1	70	95	145	190	210	65	85	125	165	210	60	80	120	150	210
SRM/E / HSRM 15-2	145	190	290	385	420	120	175	270	360	420	115	165	260	340	420
SRM/E / HSRM 20-1	60	75	115	155	160	50	65	105	140	160	45	65	100	135	160
SRM/E / HSRM 20-2	115	155	230	305	350	100	135	200	270	350	90	130	195	255	335

CWM Specifications

Model	Circuit Load (Amps / Ft.)	Max Circuit Length (Ft.)
CWM 4-1CT	0.033	350
CWM 8-1CT	0.067	240
CWM 12-1CT	0.100	200
CWM 4-2CT	0.017	700
CWM 8-2CT	0.033	480
CWM 12-2CT	0.050	400
CWM 12-4CT	0.025	780

SRF Circuit Breaker Selection (Max. Circuit Lengths in Ft.)

Cable Rating	40°F Start-Up (Ft.)			0°F Start-Up (Ft.)		
	15A	20A	30A	40A	50A	50A
SRF 3-1C	350	360	NR	270	360	NR
SRF 3-2C	660	NR	NR	555	660	NR
SRF 5-1C	230	270	NR	180	270	NR
SRF 5-2C	450	540	NR	360	540	NR
SRF 8-1C	180	215	NR	145	215	NR
SRF 8-2C	330	420	420	265	395	420

SLL SPECIFICATIONS

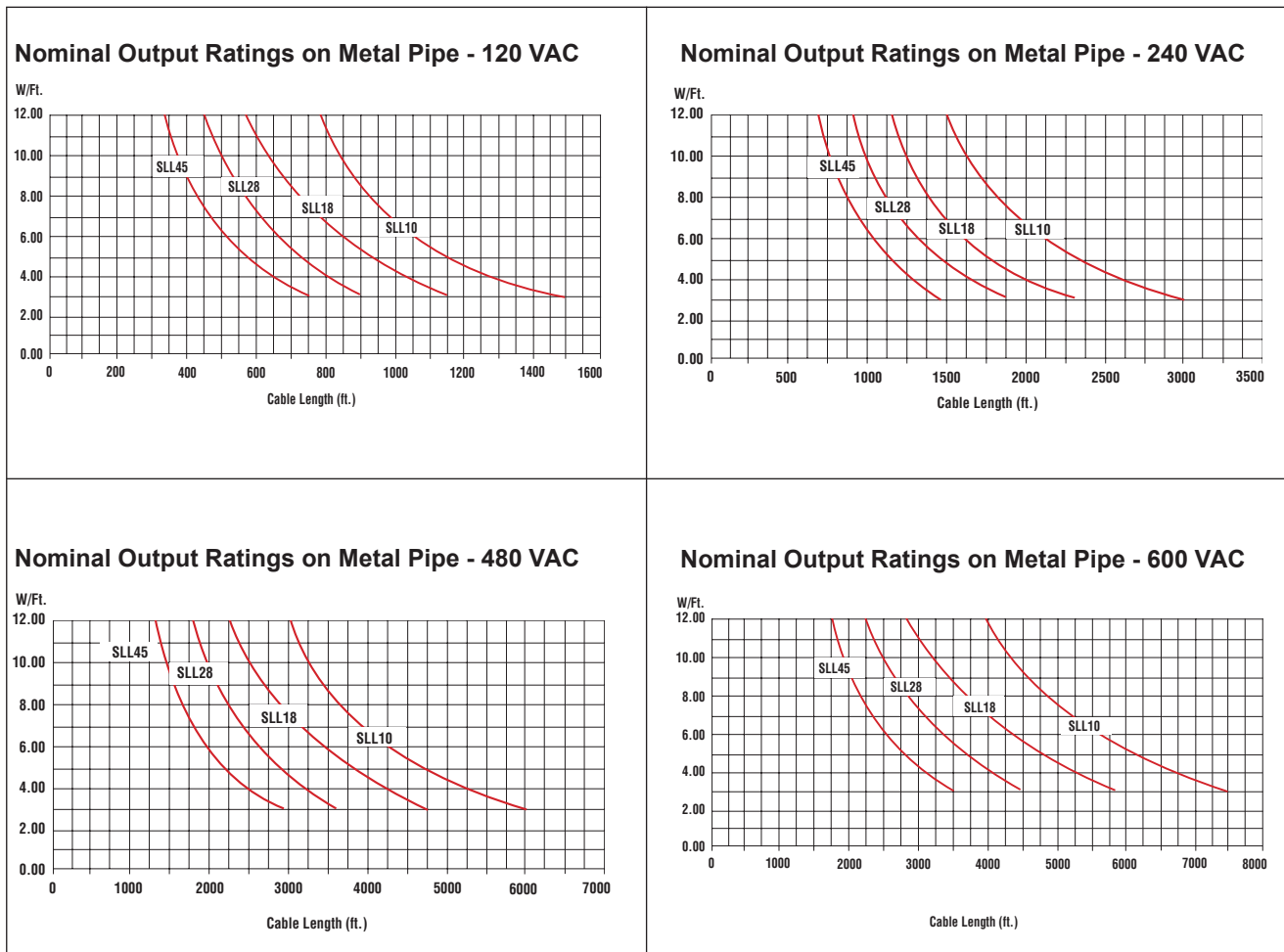

NR = Not Required. Maximum circuit length has been reached in a smaller breaker size.

Note — Thermal magnetic circuit breakers are recommended since magnetic circuit breakers could “nuisance trip” at low temperature.

MAINTENANCE

Recommended maintenance for MIFAB® heat tracing systems consists of performing the steps involved in the commission testing on a regular basis. For those systems controlled by line sensing thermostats, MIFAB® recommends checking the system at least twice per year. Systems controlled by an ambient-sensing thermostat should be checked when the season requiring their use is approaching.

Repair or replace all damaged heater cable, connections, thermal insulation and weatherproofing using only MIFAB® connections and methods before testing the system. Record all repairs made and measurements taken in the installation and maintenance log.

INSTALLATION AND MAINTENANCE LOG

Reference Information

Circuit Number								
Circuit Breaker Number								
Drawing Number								
Circuit Length								

Heat Tracing Visual Checks

No Signs of Moisture, Corrosion or Damage	Initial							
	Date							
Proper Electrical Connection	Initial							
	Date							
Proper Grounding of the Braid	Initial							
	Date							

Heat Tracing Electrical Checks

Megger Test (500 VDC) (Bypass Controls)	Meg Ohms							
	Date							
Amperage Draw Test Compare to design Amperage Draw	Amperage							
	Amp. Temp							
	Date							
Voltage at end of Circuit*	Voltage							
	Date							

Accessories/Control Checks

Temperature Control Properly Set	Setpoint							
	Date							
Sensors Protected and Undamaged	Initial							
	Date							
All Enclosures and Kits Closed and Sealed	Initial							
	Date							

Thermal Insulation Checks

Location of Kits Visible on Outside of Insulation	Initial							
	Date							
Insulation is Complete, Dry and Weatherproof	Initial							
	Date							

* This test must be performed at installation or at any time the cable is cut or damaged in any way.

DIVISION 1 / ZONE 1 – CHECKLIST EXAMPLE

Location:	System / Project Number	Reference Drawing(s)	
Circuit ID #	Test Value / Remarks	Date	Initials
Area:			
Ignition Temperature			
Group Classification			
Trace Heater Circuit:			
Trace Heater type			
Supply Voltage			
Circuit Length			
Design Maximum Pipe Temperature			
Trace Heater Device Temp Identification Number (T-rating)			
Components:			
Power Connection			
End Seal			
Tee Connection			
Splice			
Ground-Fault Protection			
Make & Model			
Ground Leakage			
Trip Level (mA)			
Installation Instructions:			
Correct Components Per Manufacturers Specification			
Seal Fittings (when used) Opened and Inspected (properly poured)			
Ground-Leakage Device Tested			
Insulation Resistance Testing:			
Instrument Used			
Calibration Date			
Megohmmeter Test Voltage (minimum 500 VDC, recommended 1000 VDC for MI, 2500 VDC for polymeric)			
Electrical Jacket Before Thermal Insulation Installed (minimum value shall be 20 megohms)			
Overjacket Before Thermal Insulation Installed (minimum value shall be 20 megohms- Div. 1 only)			
Overjacket After Thermal Insulation Installed (minimum insulation resistance value shall be 20 megohms- Div. 1 only)			

Circuit Ready to Commission

Name (Print): _____ Signed: _____

Company: _____ Date: _____



**CERTIFIED
MANAGEMENT SYSTEM
ISO 9001:2015**

Cable



Download this catalog
to your digital device

**Installation Instructions
Industrial Heating Cable Products
LIT-097**