

Location: _____



MIFAB® T1500-PG-FPC-500

**6" WIDE, 19.68" LONG, GALVANIZED STEEL,
PERFORATED, HEAVY DUTY (LOAD CLASS C) GRATE**

Specification: : MIFAB T1500-PG-FPC-500, heavy duty, (Load Class C), galvanized steel, reinforced perforated grate is 4.80" wide x 19.68" long, weighing 3.22 lbs. per linear foot. The grate has 1/4" diameter holes and has a free open area of 14.11 square inches and is ADA compliant and H-20 load rated. The grate is secured to the body with a four point self-locking (snap in) system. Galvanized steel conforms to ASTM Standard A653, galvanized coating designation G60. The grate also complies with ASME Standard A112.6.3-2001: Section 7.12, Heel Resistant Strainers and Grates.

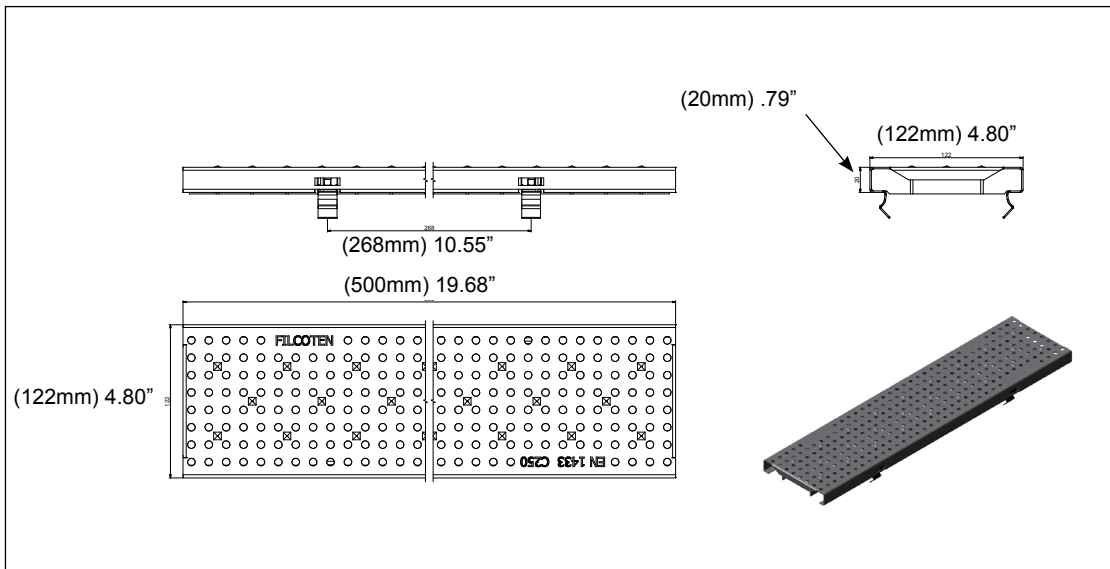
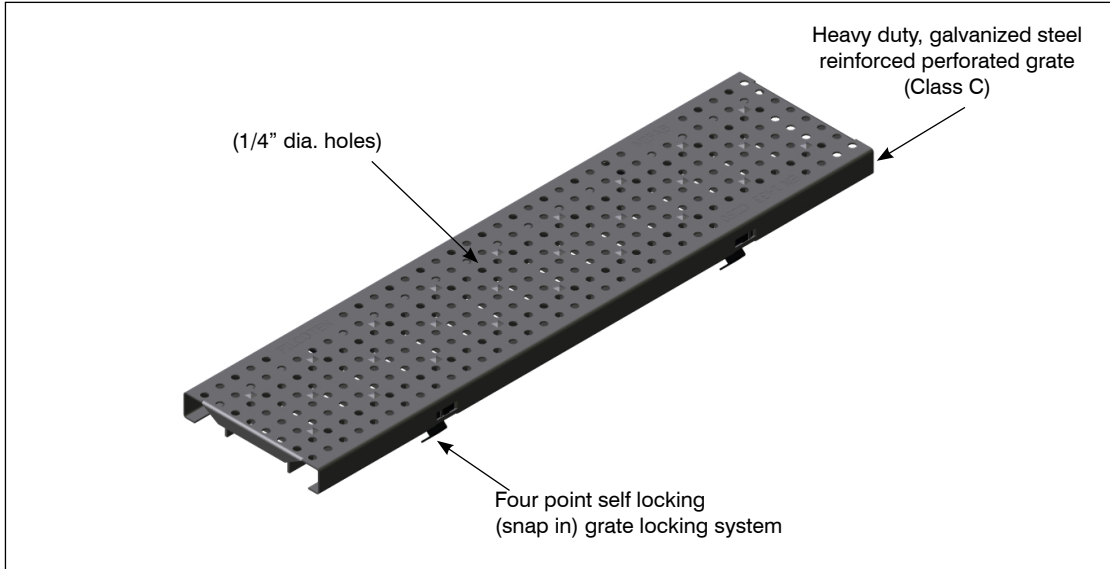

Load Class C- Heavy Duty, DIN 19580, 56,000 lbs. 1.162 psi. For commercial pneumatic tire traffic patterns and tractor trailers.

Job Name: _____
Section No: _____
Schedule No: _____

Page No: _____
Contract: _____
Purchase Order No: _____

MIFAB reserves the right to make changes in material and design without formal notice or obligation.

USA: 1-800-465-2736 www.mifab.com CAN: 1-800-387-3880