

Specification: MIFAB® Series XL-MI-G-PL parallel installation of multiple Mig Max units for higher grease storage and flow rate requirements. It is recommended to install a cleanout prior to the first unit, after the last unit, and between each unit if long runs of pipe are required.

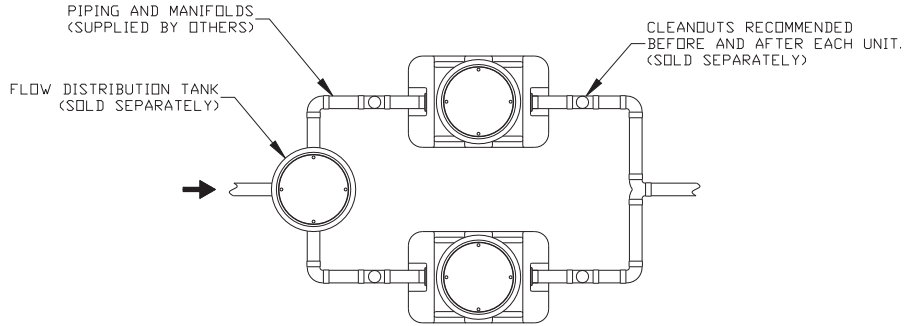

XL-MI-G-PL-750 TWO IN PARALLEL
150 GPM, 1500 GREASE LBS. CAPACITY

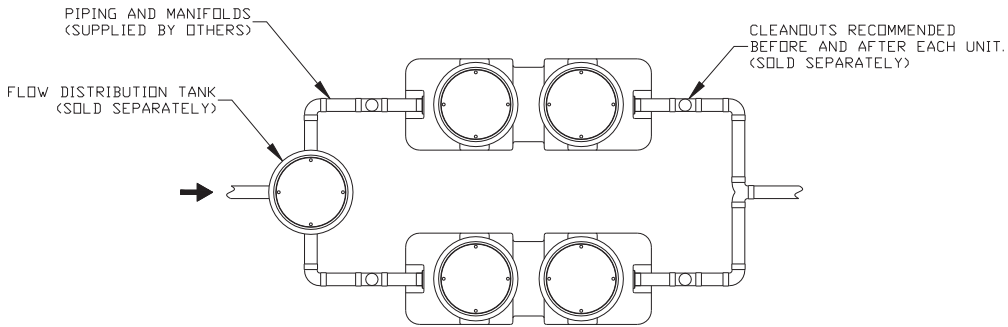

XL-MI-G-PL-1150 TWO IN PARALLEL
200 GPM, 2300 GREASE LBS. CAPACITY

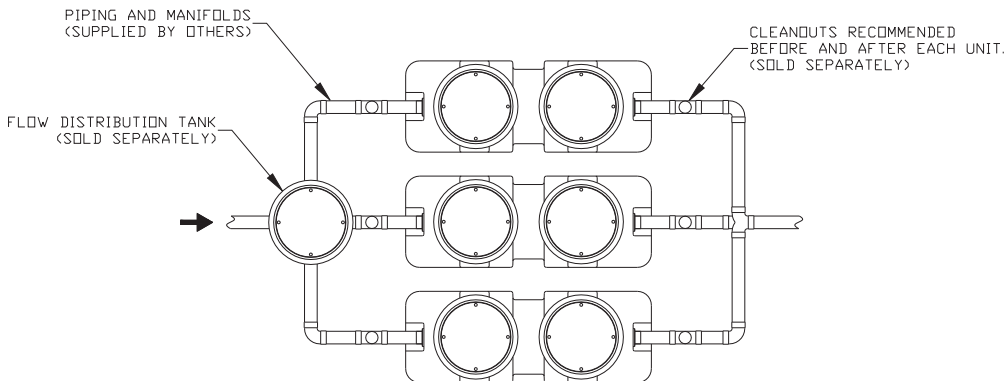

XL-MI-G-PL-1150 THREE IN PARALLEL
300 GPM, 3450 GREASE LBS. CAPACITY

Job Name: _____	Page No: _____
Section No: _____	Contractor: _____
Schedule No: _____	Purchase Order No: _____