

D-B; 6MC H 9FG
FD9F @ 7 5 @ 7 C 8 9L

i 5 @ D-B; K @-B GH5 @ 98 '6MC H 9FG' 5 B 8 'G < C I @ 8 : C @ C K '
@ 7 5 @ F 9; I @ 5 H C B G ' 5 B 8 ' 5 D D F C J 9 8 ' 6 M D F C > 9 7 H 9 B; B 9 9 F "

i 5 @ 9 @ 7 H F = 7 5 @ G < C I @ 8 ' 6 9 ' B GH5 @ 98 ' 6 M @ 7 9 B G 9 8 '
D F C : 9 G G C B 5 @ 5 B 8 ' G < C I @ 8 : C @ C K '@ 7 5 @ F 9; I @ 5 H C B ' 5 B 8 '
5 D D F C J 9 8 ' 6 M D F C > 9 7 H 9 B; B 9 9 F "

DFC: 4B F M 5 B 8 7 C B: 6 9 B H 5 @
H 9 B: C F A 5 H C B 7 C B 1 6 B 9 8 B H G
B F 5 K B: G H 9 C C @ 9 D F C D F M C:
A = 5 6 2 B 7 * 5 B M F 9 D F C 8 1 7 H C B B
D 5 F H C F 5 G 5 K < C @ 9 K # C I H H 9
K F H H B D 9 F A G G C B C : A = 5 6 2 B 7 * G
D F C < 6 4 9 B *

@ 5 G 9 F # G < 9 5 F .	I B @ 9 G C H 9 F K @ 9 D 9 7 = 9 8 .	B 5 A 9	B 5 H 9		
6 F 5 ? 9 D F 9 G G	8 A 9 8 G C B G 5 F 9 B B 7 < 9 G H C @ F 5 B 7 9 G : F 5 7 H C B 5 @ 9 9 9 5 B : 1 @ 5 F ' A 5 7 < ± 9 6 9 8 B ± 9 H C D @ 5 7 9 B 9 7 ' A 5 @ ± 5 9 H F 9 9 D @ 5 7 9 B 9 7 ' A 5 @ ± 5 9 H D 7 5 @ 8 F 5 : H 5 B : @ 9 &	8 F 5 K B	A A		H @ 9 % \$ \$: DA < 8 D 9 ; FG B H # 9 9 \$
K 9 @ 8 9 8 ' 6 M	A 5 H F 6 9 8 6 7 F @ H C B G 9 9 1 6 C A	7 < 9 7 9 9 8	LL		@ G ; FG < @ 7 5 D " G 9 @ ! 7 @ 9 5 B B ; ' G M G 9 A
7 @ 9 5 B # D 5 B H		9 8 : 5 D D F "	E 5 "	GN 9 8 K ; " " B C "	
7 C A D @ 9 8 ' 6 M		A : : 5 D D F "	E 1 5 B H M	6 ÷ ! 9 9 9 \$! G 7	
F 9 J 9 K 9 8 ' 6 M				F 9 J	
B 9 L H 5 G M	I 9 9 8 C B	: B G : D 5 F H	G 9 9 1 D C .	G 7 5 @ 9 . % & (K 9 ÷ < H ' G < 9 9 H % C : *	
5 D D @ 7 5 H C B		LL			
		8 C B C H 7 5 @ 9 8 F 5 K B :			

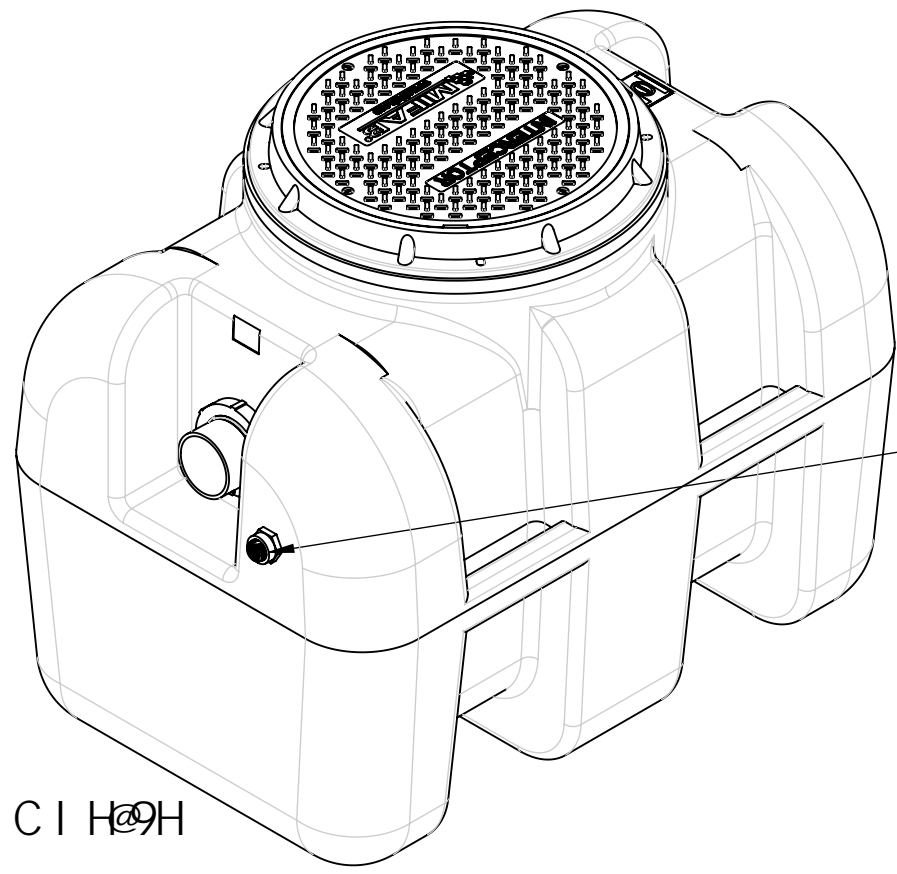

C I H@H

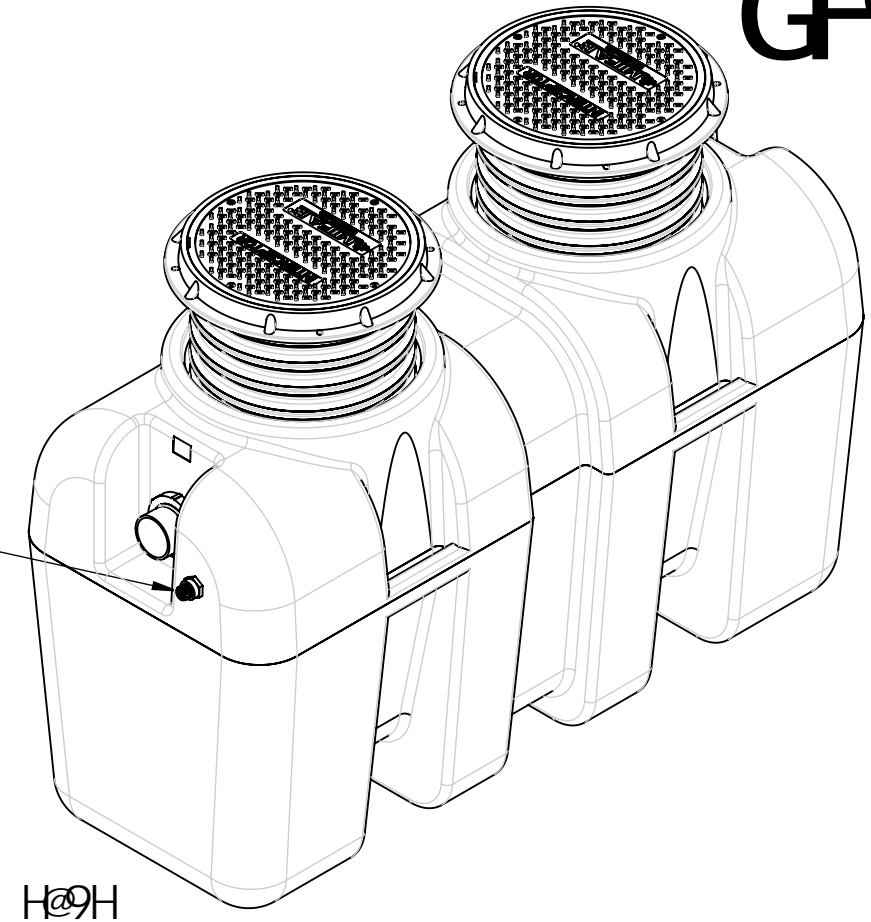
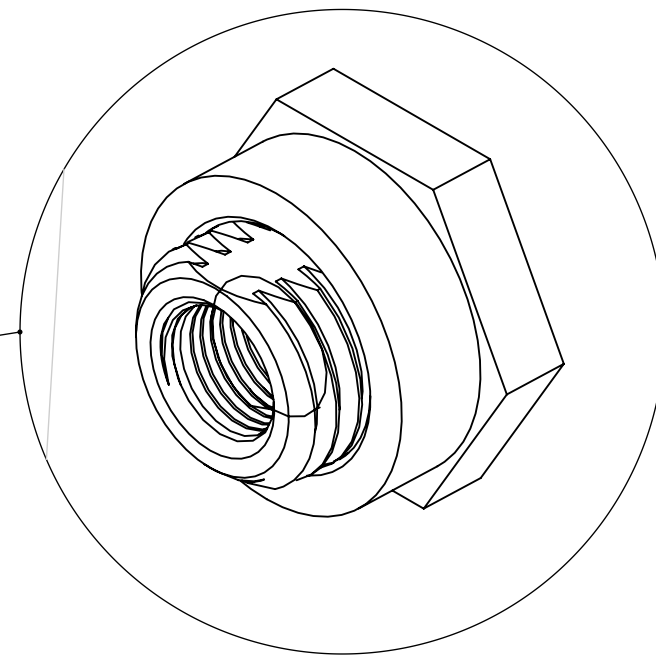

C I H@H

G-PD. %

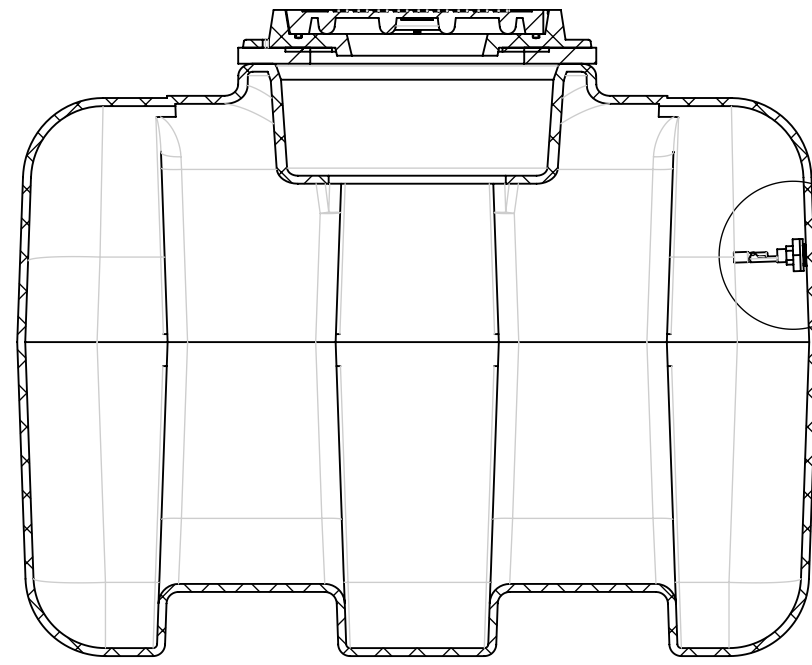

B@H

C I H@H

GK #7 < 'G'G<C K B 'B' H'K 9 'CB' DC G+H< B "
GK #7 < K @@<5B; '8C K B'K <9B 'C::"

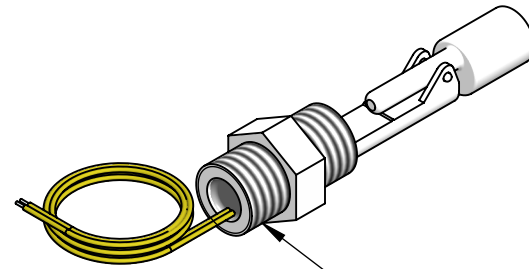

K F5 D'H'k'F958G'K #k 'H9. @C B 'H5D9
69:C F9'H'k'F958-B; 'BHC '7 C I D@B; "
7CF8G'5F9&f@C B; "'# @C B; 9F @9B; H'k'GF9E I #98
I G9'&&'U" \$\$J 'K #9: C F'GD@7 B; "

G-PD. &

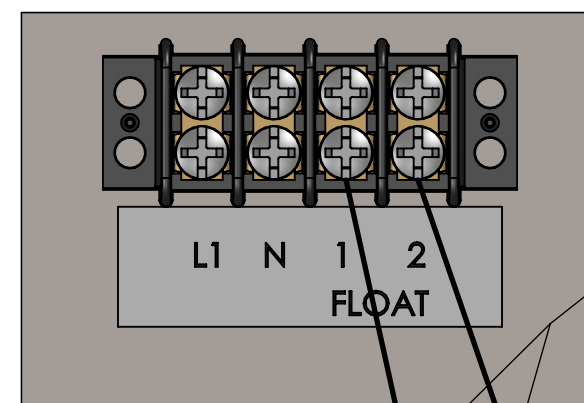

CB 7 9'G'K #7 < 'K #9G'5F9; 998 'BHC '6C L
7 C BB97 HC B9'K #9'HC 'DC FH%K 9B
C B9'K #9'HC 'DC FH&'C: '5@FA 'GMGH9A "

G-PD. ' "

8 9H @7
G7 5 @9% %

BC H@.

- i 7 CBHC @6CL '5FFJ 9G'K #k 'H'95@FA ' K #9G>I A D98"
- i <# < @J 9@5@FA 'G<C I @8 '69'K #98 'HC ' 7CBHC @6CL 'D9'K #B; 'BGFI 7HCBG'
- i <# < @J 9@5@FA 'G'K #7 < 'A I GH69'K #98 'B'7 C A D@5B79K #k '@75@7C 89G'

7 C BHC @6CL 'G<C I @8 '69
A C I BH@8 'HC 'H'9'B95F9GHK 5 @
C F 'D9FA 5B9BHGF I 7 H F9"

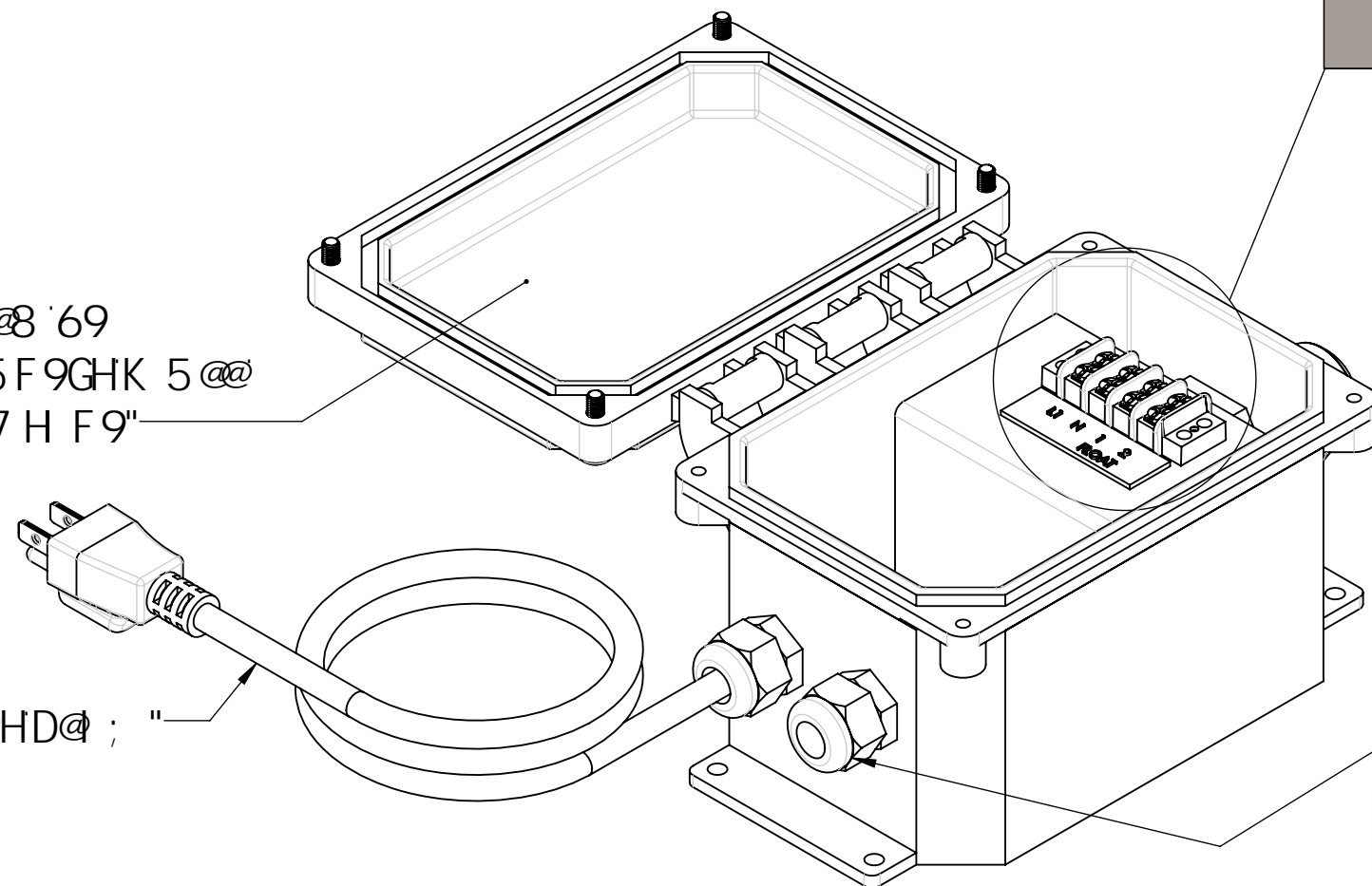

: 998 'G'K #7 < 'G'K #9G
'BHC 'C D9B 'DC FH'

* f@C B; '%&\$'J 57
GH5B85F8 'C I H@HD@ ; "

D'CF@BFM588 7CB: @98H5@
H'9'B: CFA 5HC B 7 C B16 B98 'B'K-G
BF5K: B: 'G'H'9CC@9DFC D9FHC.
OBGFH7 C A D5BMB5A 9<9'92" 5BM
F9DF B I 7 HC B 'B D5FHC F 5G5 K <C @
K #k C I H'k'9'K F #H@B 'D9FA 6GC B C:
OBGFH7 C A D5BMB5A 9<9'92 G
D'K <@H@

@G9F #G< 95 F.	I B @9G C H: 9'K @9'D97 = 98.	B5A 9	B5H@	
6F5?9DF9GG	8 A 9B GC BG5F9-B #7 <9G H@F5B7 9G : F57 HC B5 @9%9@ 5B: I @F 'A 57 < 9' 698 B ±% H' C D@5 7 9 B97 'A 5 @' ±5% H: F99 D@5 7 9 B97 'A 5 @' ±5% H D7 5 @8 F5: H5 B: @9' & "	8F5K B	LL \$' #&' #98%	
K 9@8 98 '6M	A 5H@F 5@8 G7 F @H C B D@5 G H7	7 < 97 798	98: '5DDF"	H@9 G-8 9'A C I BHD'Ug]WCK #7 <
7 @95 B #D5-BH	'B G: D5FH	A:: '5DDF"	E '5"	
7 C A D@H98 '6M			E I 5BHM	
F9J 9K 98 '6M				
B9LH5GM	I98 C B			G99: 6C A
	5DD@7 5HC B			
	8 C B CHG7 5@8 8F5K B:			

GN9 8K: "'BC"
7 <# < @J 9@5@FA ' F9J
GK #7 <
G7 5 @9. %&'K 9# <H'LLLLLLIQ: 99H&C: *

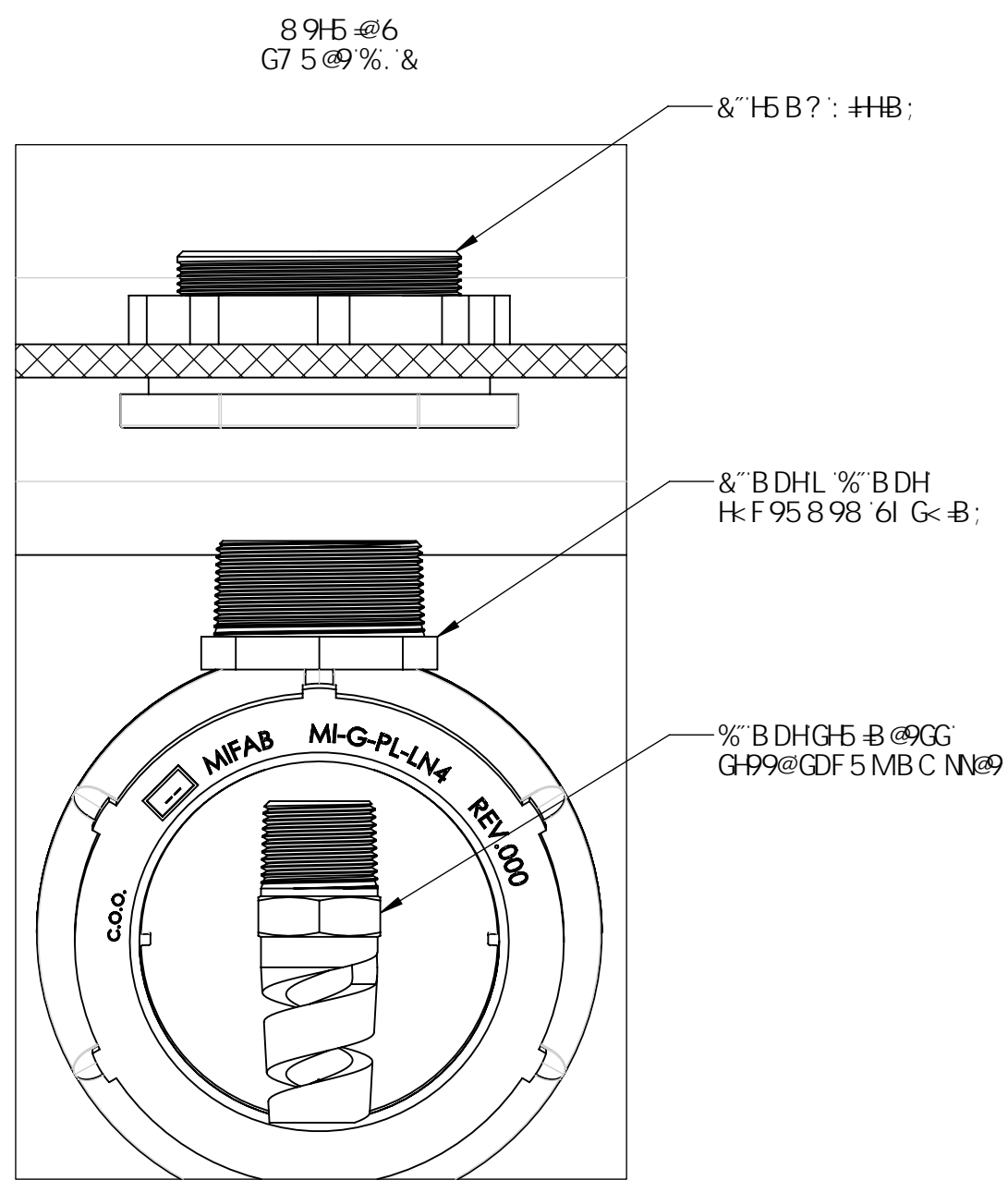

fIB @HIF5D < 889B
: CF 7 @5F9F J 9K L

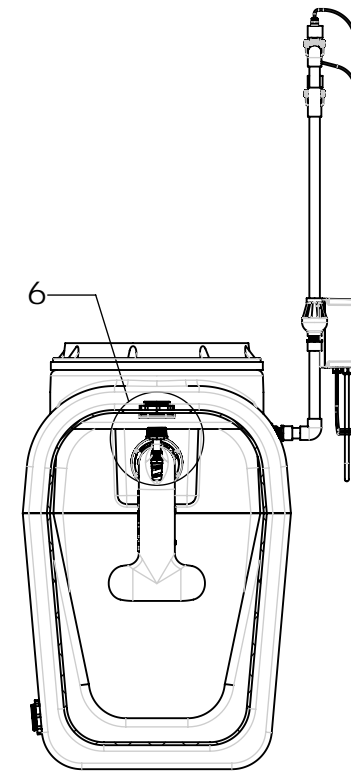

G97 HC B '515

C D9F5HC F IG 6C L
fIG99K F-B ; 8-5 ; F5A
: CF 89H5 @L

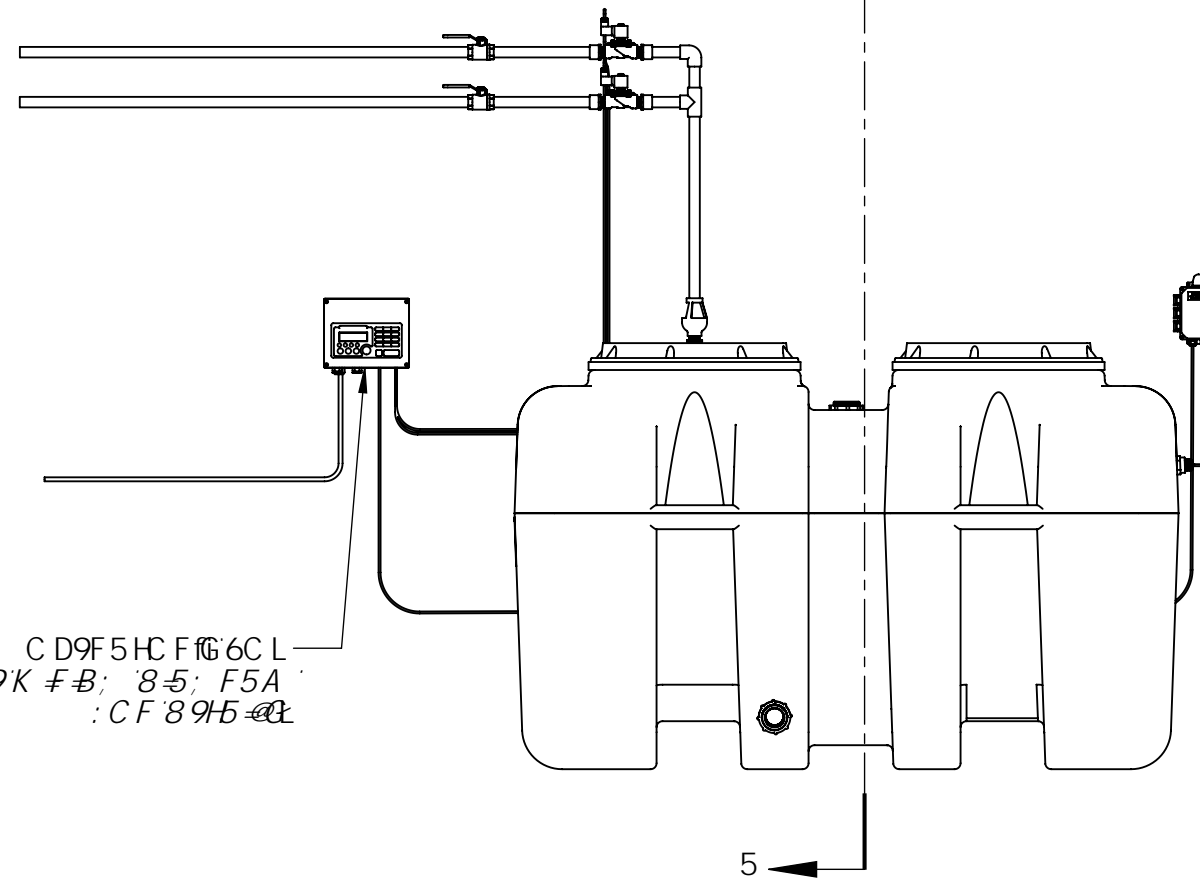

- % "I G9D: H9'H5 D9'CF 'HkF958 'G95 @BHC BHC 'Hk9' &"HkF95898 '6l G<B ;
5B8 'BG5 @-BHC '&"H5B? : #HB ; "
- & "I G9D: H9'H5 D9'CF 'HkF958 'G95 @BHC BHC 'Hk9' %"HkF95898 'GDF5MBC NN@9
5B8 'BG5 @-BHC 'Hk9' %"BDHkF958-B ; 'CB 'Hk9'6l G<B ; "

DFC#4#FMS887CB: 89H5@
H-9-B: CFA5HC B 7C B16 B98 B Hk-G
BFSK-B: G1H-9CC-99DFC D9FIMC:
A=562-B7 "SBMF9DFC817HC B-B
D5FHCF5G5 K <C @9K #K C1 Hk-9
K F Hk8 D9FA 4GC B C: A=562-B7 "G
DFC < 4#98"

@G9F #G< 95 F .	1 B @9GC H: 9FK 69 QD97 = 98.	B5A 9	85H9	
6F5?9DF9GG	8A 98GC BG5F9-B #7 <9G HC @F5B7 9G : F57HC B5 @-%98 5B: 1 @5F 'A 57 < ±% "698 B ±% Hk C D#57 9B97 'A 5 @ ±% Hk F 99 D#57 9B97 'A 5 @ ±% Hk D 7 5 @8F5: H5B: @9 &	8F5K B	A A	
K 9@898 '6M	A 51#F 5@98 67 F #HC B G99!6C A	7 < 97 798	LL	H#9 %\$ \$: DA < 8D9; FG-BH#%0 \$
7 @95 B #D5-BH		98: '5DDF"		@G; FG < @ 7 5 D "G9@!
7 C A D @H98 '6M		A: '5DDF"		7 @95 B-B; 'GMH-9A
F9J 9K 98 '6M		E '5"		GN9 8K ; "'BC"
B9LH5GGM	I 998 C B	E I 5B#M		7 6 ÷ !%0 \$!G7
	LL			F9J
	5DD#7 5HC B			G7 5 @. %& (K 9# < H'
				G< 99H' 'C: *

G99!DC

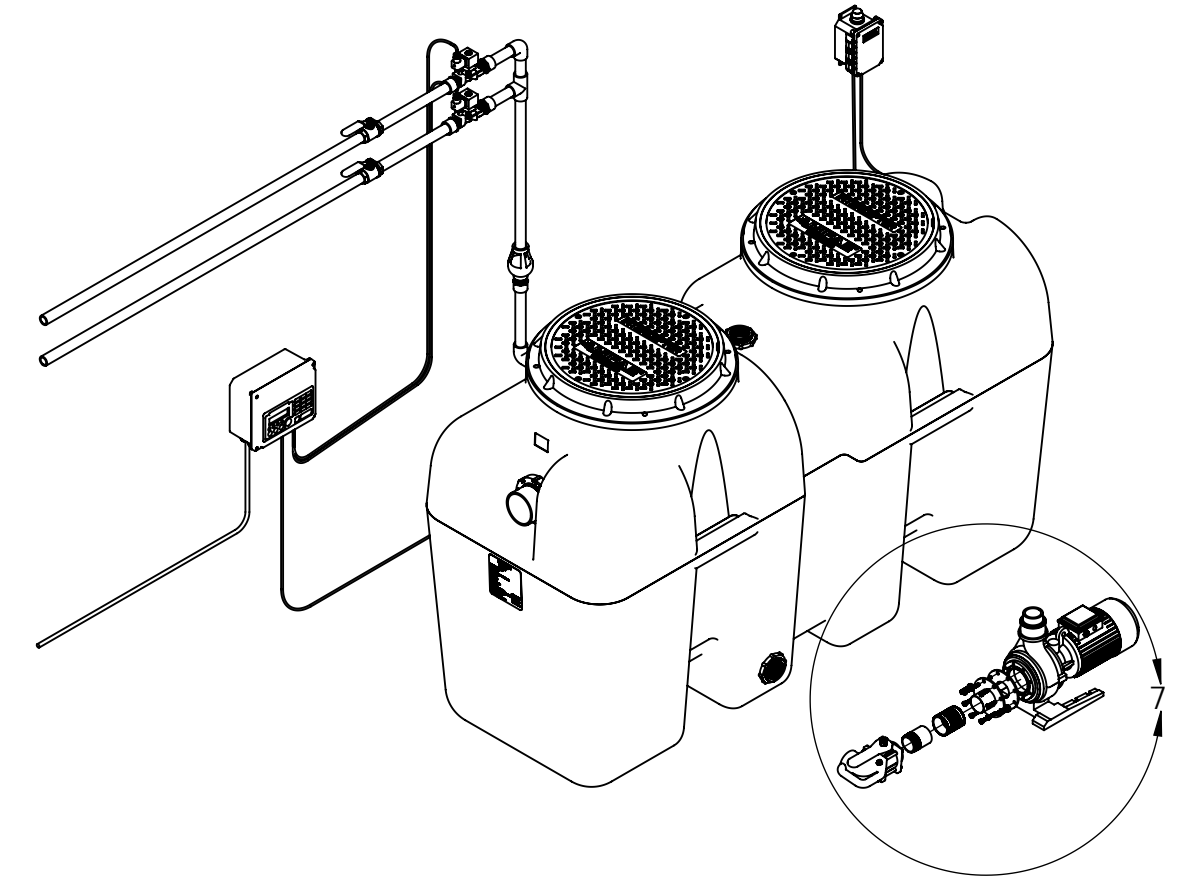
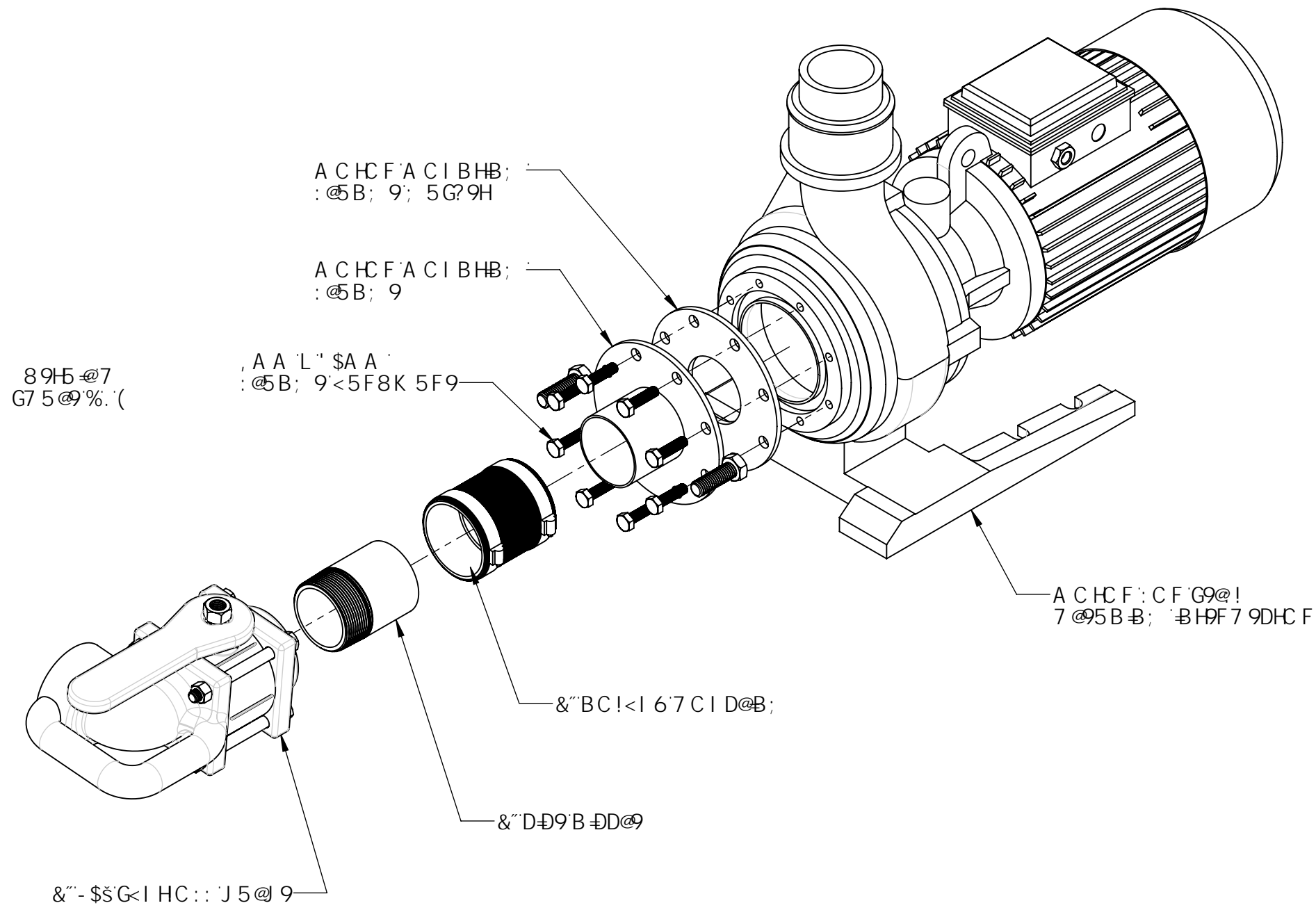

- 1) " " I G 9 D : H 9 H 5 D 9 C F ' H k F 9 5 8 ' G 9 5 @ B H C B H C ' H k 9 ' D @ 9 B @ D @ 9 ' H k F 9 5 8 G 5 B 8 ' B G H 5 @ @ B H C ' & " - \$ \$ G < I H C : : J 5 @ 9 "
- () " " @ B 9 I D ' H k 9 < C @ G C B ' H k 9 A C H C F A C I B H : @ B; 9; 5 G 7 9 H ' H k 9 A C H C F A C I B H B; : @ B; 9 Z 5 B 8 ' H k 9 ' A C H C F 5 B 8 ' B G H 5 @ @ H C; < 9 H k 9 F I G B; ' H k 9', A A ' < 9 L ' < 9 5 8 ' 7 5 D ' G 7 F 9 K G "
-) " " B G H 5 @ @ H k 9 & " - \$ \$ G < I H C : : J 5 @ 9 ' H C ' H k 9 A C H C F : C F ' H k 9 G 9 @ ! 7 @ 5 B - B; ' B H F 7 9 D H C F ' I G B; ' H k 9 & " B C ! < I 6 7 C I D @ B; " f G 9 9 ' 8 9 H 5 @ C B ' G 8 9 L
 - i @ C C G 9 B ' H k 9 G 7 F 9 K G C B ' H k 9 7 C I D @ B; "
 - i G @ 8 9 ' H k 9 & " ' H k F 9 5 8 9 8 ' B @ D @ 9 f B C ! < I 6 7 C I D @ B; ' I B H @ H k 9 : # H B; ' < # G ' H k 9 ' 6 F - 8; 9 ' B G 8 9 ' H k 9; 5 G 7 9 H "
 - i @ 7 < H @ M H 7 < 9 H k 9 B ' H k 9 G 7 F 9 K ' C B ' H k 9 G 8 9 C : ' H k 9 7 C I D @ B; ' H k 5 H < 5 G ' H k 9 D @ 9 B @ D @ 9 "
 - i G @ 8 9 ' H k 9 B C ! < I 6 7 C I D @ B; ' C B H C ' H k 9 A C H C F A C I B H B; : @ B; 9 Z I B H @ H k 9 : # H B; ' < # G ' H k 9 ' 6 F - 8; 9 ' B ' H k 9; 5 G 7 9 H "
 - i C B 7 9 ' H k 9 I B # G 5 F 9 ' B Z : I @ @ M H 7 < H 9 B ' 6 C H k ' G 7 F 9 K G C B ' H k 9 B C ! < I 6 7 C I D @ B; "

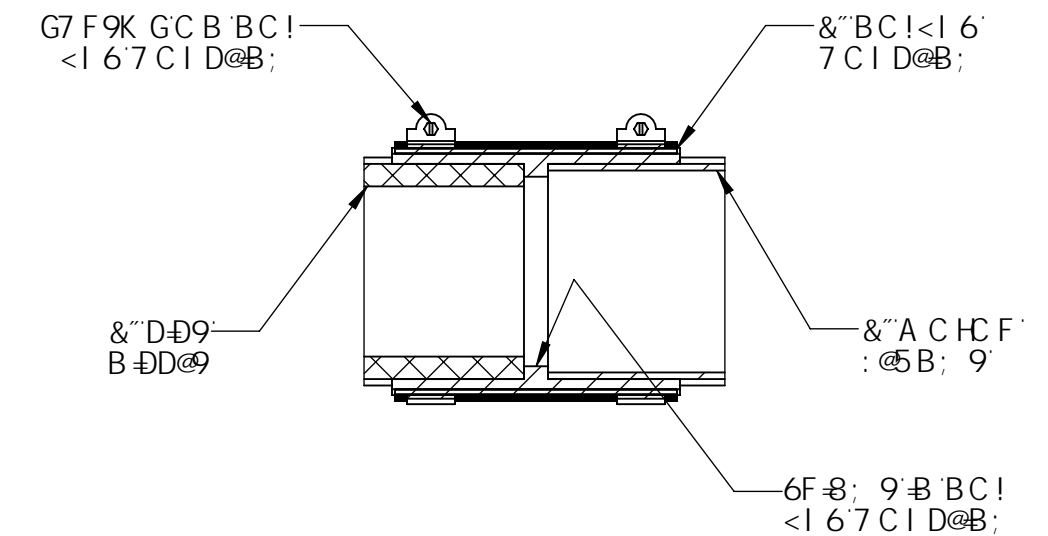

D F C F @ B F M 5 B 8 7 C B : @ 9 B H 5 @
 H 9 B : C F A 5 H C B 7 C B 1 6 B 9 8 ' B H k G
 B F 5 K B : G H 9 C @ 9 D F C D F M C :
 A = 5 6 2 B 7 " 5 B M F 9 D F C 8 I 7 H C B - B
 D 5 F H C F 5 G 5 K < C @ 9 K # C I H k 9
 K F H H B D 9 F A G G C B C : A = 5 6 2 B 7 " G
 D F C < 6 4 9 8 "

@ G 9 F # G < 9 5 F .	I B @ 9 C C H : 9 F K @ 9 D 9 7 = 9 8 .	B 5 A 9	8 5 H 9	
6 F 5 ? 9 D F 9 G G	8 A 9 8 G C B G 5 F 9 - B @ 7 < 9 G H C @ 9 F 5 B 7 9 G : F 5 7 H C B 5 @ 9 9 8 5 B : I @ 5 F ' A 5 7 < ± 9 8 ' 6 9 8 8 ± 9 8 H k C D @ 5 7 9 8 9 7 ' A 5 @ : ± 5 9 8 H k F 9 9 D @ 5 7 9 8 9 7 ' A 5 @ : ± 5 9 8 H k D 7 5 @ 8 F 5 : H 5 B : @ 9 7 & "	8 F 5 K B	A A	
K 9 @ 8 9 8 ' 6 M	A 5 H F 6 @ 9 8 6 7 F @ H C B G 9 9 I 6 C A	7 < 9 7 9 8	LL	H @ 9 % \$ \$: D A ' < 8 D 9; F G - B H # 9 8 \$
7 @ 5 B # D 5 - B H		9 8 : 5 D D F "		A : : 5 D D F "
7 C A D @ 9 H 8 ' 6 M		E 5 "		H @ 9 % \$ \$: D A ' < 8 D 9; F G - B H # 9 8 \$ @ G; F G < @ 7 5 D " G 9 @ ! 7 @ 5 B - B; ' G M G - 9 A
F 9 J - 9 K 9 8 ' 6 M		E I 5 B H M		G M 9 7 8 K ; " " B C " 6 ÷ ! 9 8 9 \$! G 7
B 9 L H 5 G M	I 9 8 C B			F 9 J
5 D D @ 7 5 H C B		8 C B C H G 7 5 @ 9 8 F 5 K B :		G 7 5 @ 9 . % & (K 9 ÷ < H ' G < 9 9 H (C : *)

89H5 @8
G7 5 @9 % . (

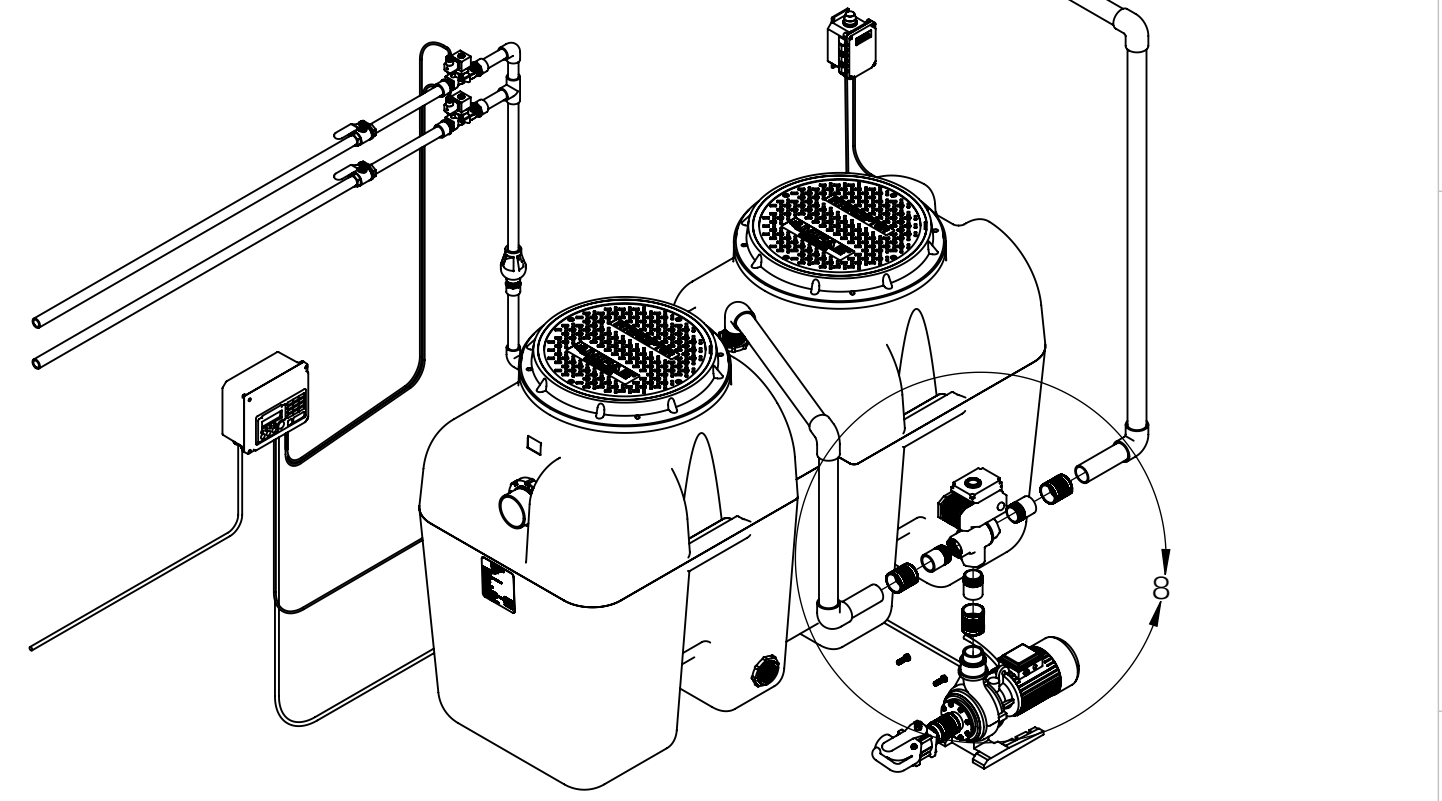
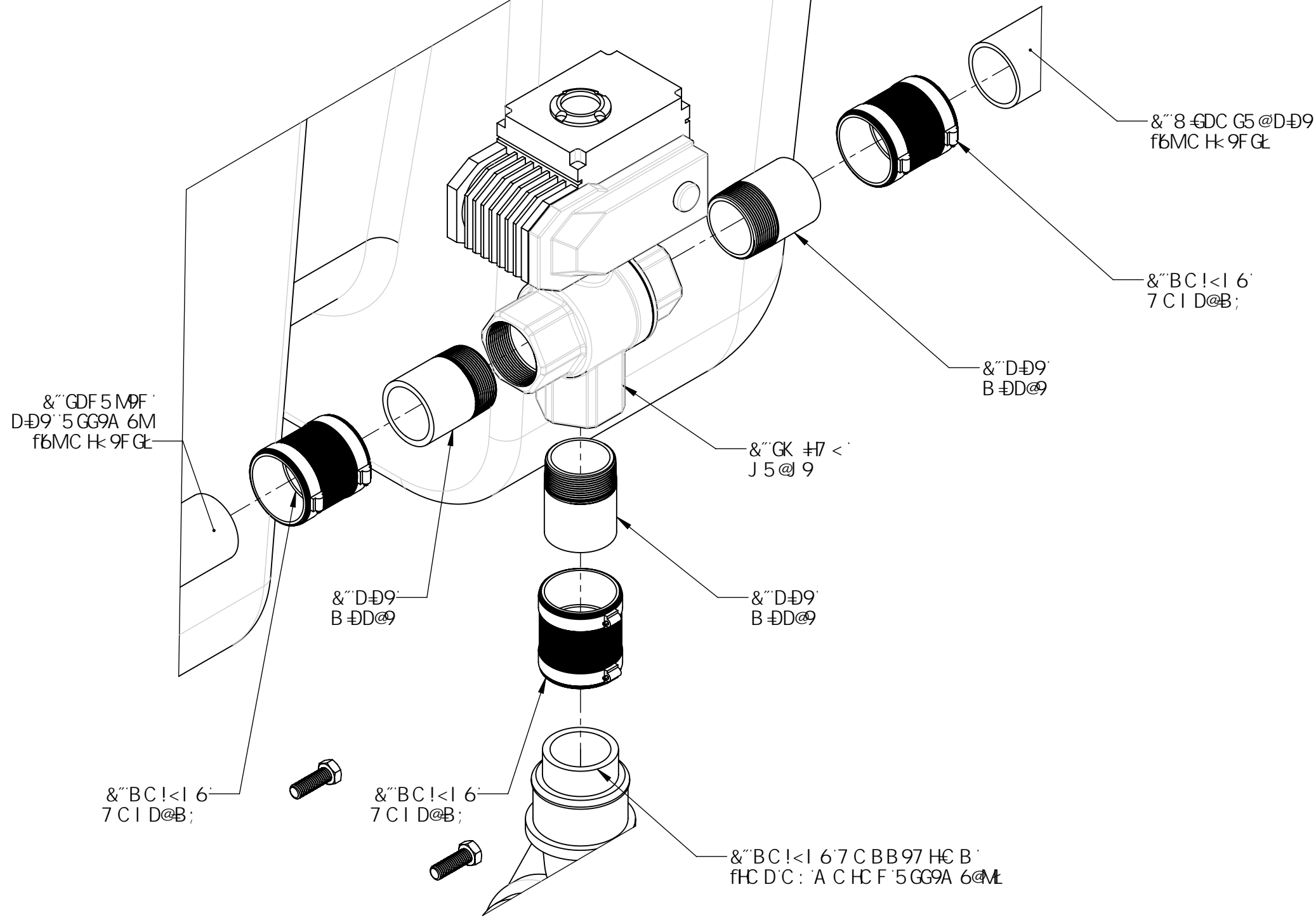

- (*) ""I G9D: H9'H5D9'C F 'HkF958 G95 @B HC BHC 'Hk9' &"HkF95898 'B-DD @9 5B8 'BGH5 @-BHC '&"GK #7 < 'J 5 @ 9"
- (+) ""8C 'Hk9'G5A 9: C F 'Hk9' C Hk9F 'Hk C '&"HkF95898 'B-DD @9G"
- (,) ""B GH5 @Hk9' &"BC!<1 6 7 C I D @B; G' C B 5 @Hk9' &"HkF95898 'B-DD @9G"
- (-) ""D @5 7 9'Hk9' &"GK #7 < 'J 5 @ 9 Z 5 GG9A 6 @98 'K #k 'Hk9' B-DD @9 5B8 'BC!<1 6 7 C I D @B; G' C B Hk9' 'Hk9' &" BC!<1 6 7 C BB97 HC B ' C B ' H C D' C: 'Hk9' A C H C F 5 GG9A 6 @M

DFCF#4BFM588 7CB: 89H5 @
H-9 B: CFA 5HC B 7 C B16 B 98 B Hk G
BF5K B: G1H 9DC @9 DFC DPF MAC:
A = 562 B 7 " 5B MF9DFC 81 7 HC B B
D5FHC F 5G5 K < C @9K #k C I Hk 9
K F H H B D9FA 4GC B C: A = 562 B 7 " G
DFC < 6 #98 "

@G9F #G< 95 F .	I B @9GC H: 9FK @9 D97 = 98.	B5A 9	85H9		
6F5?9DF9GG	8 A 9B GC BG5F9-B @7 < 9G HC @F 5B 7 9G : F57 HC B5 @9 98 5B: 1 @5F 'A 57 < ± 98 698 B ± 98 Hk C D@5 7 9 B 97 'A 5 @ ± 5 98 Hk F 99 D@5 7 9 B 97 'A 5 @ ± 5 98 Hk D 7 5 @8 F 5: H5 B: @9 & "	8F5K B	A A		%#&#&S
K 9 @8 98 '6M					7 < 97 7 98
7 @95 B #D5 B-H					98: '5DDF"
7 C A D @9 H 98 '6M	A 51HF 6 @98 67 F @H C B G99! 6 C A				A:: '5DDF"
F9J -9K 98 '6M	: B G: D5FH			E '5"	
B 9L H5 GGM	LL			E I 5 B H M	
5DD@7 5HC B	8C B CHG7 5 @9 8F5K B:				

H @9
%\$ \$: DA < 8D9; FG-BH#% @ \$
@G; FG < @ 7 5 D " G9 @!
7 @95 B-B; 'GMH-9A
GN9 8K; ""BC"
7 6 ÷ !% @ \$! G7 F9J
G7 5 @9. % & (K 9 ÷ < H' G< 99H) 'C: *

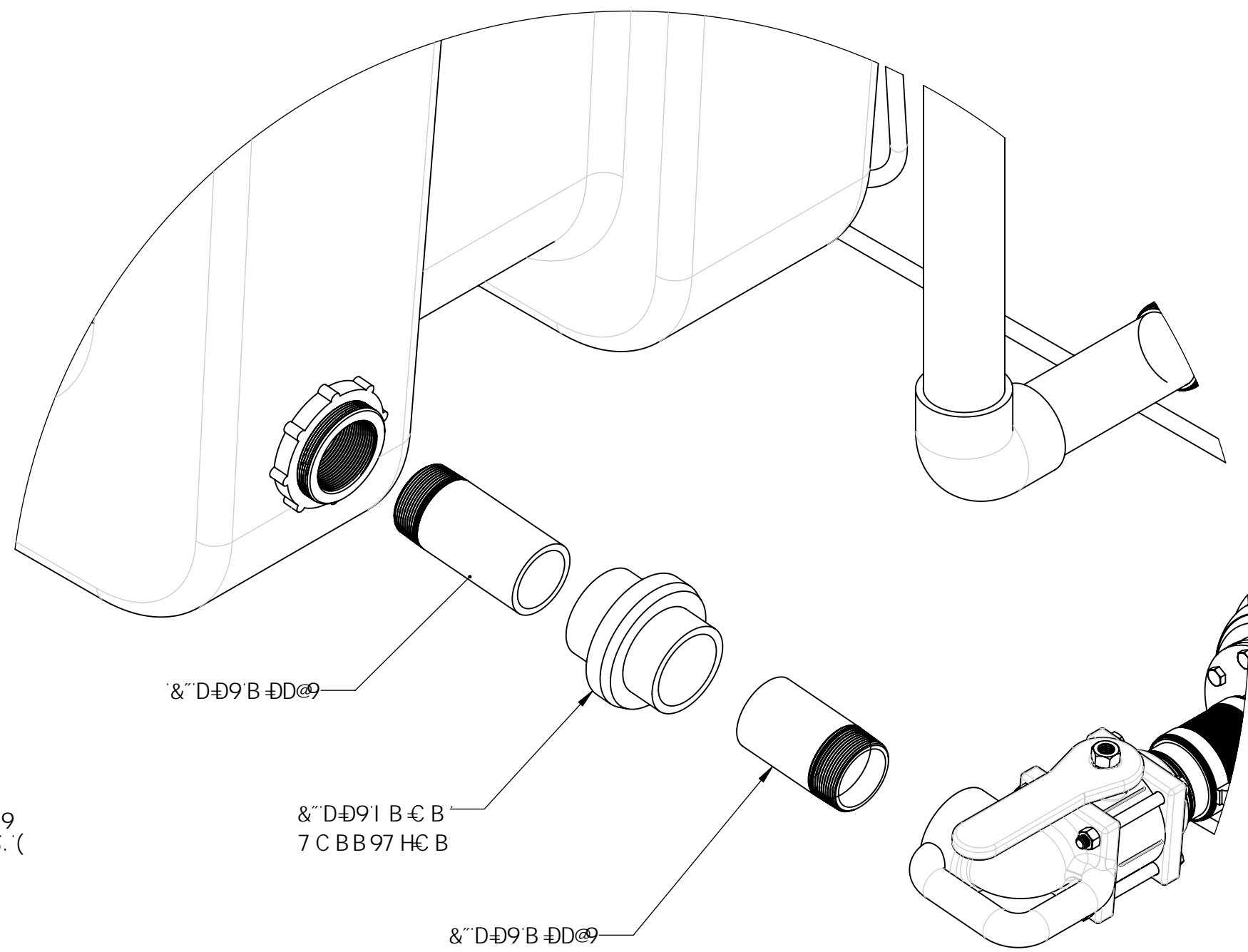

8 9 H 5 @ 9
G 7 5 @ % . (

& " D @ 9 B @ D @ 9

& " D @ 9 I B @ B
7 C B B 9 7 H C B

& " D @ 9 B @ D @ 9

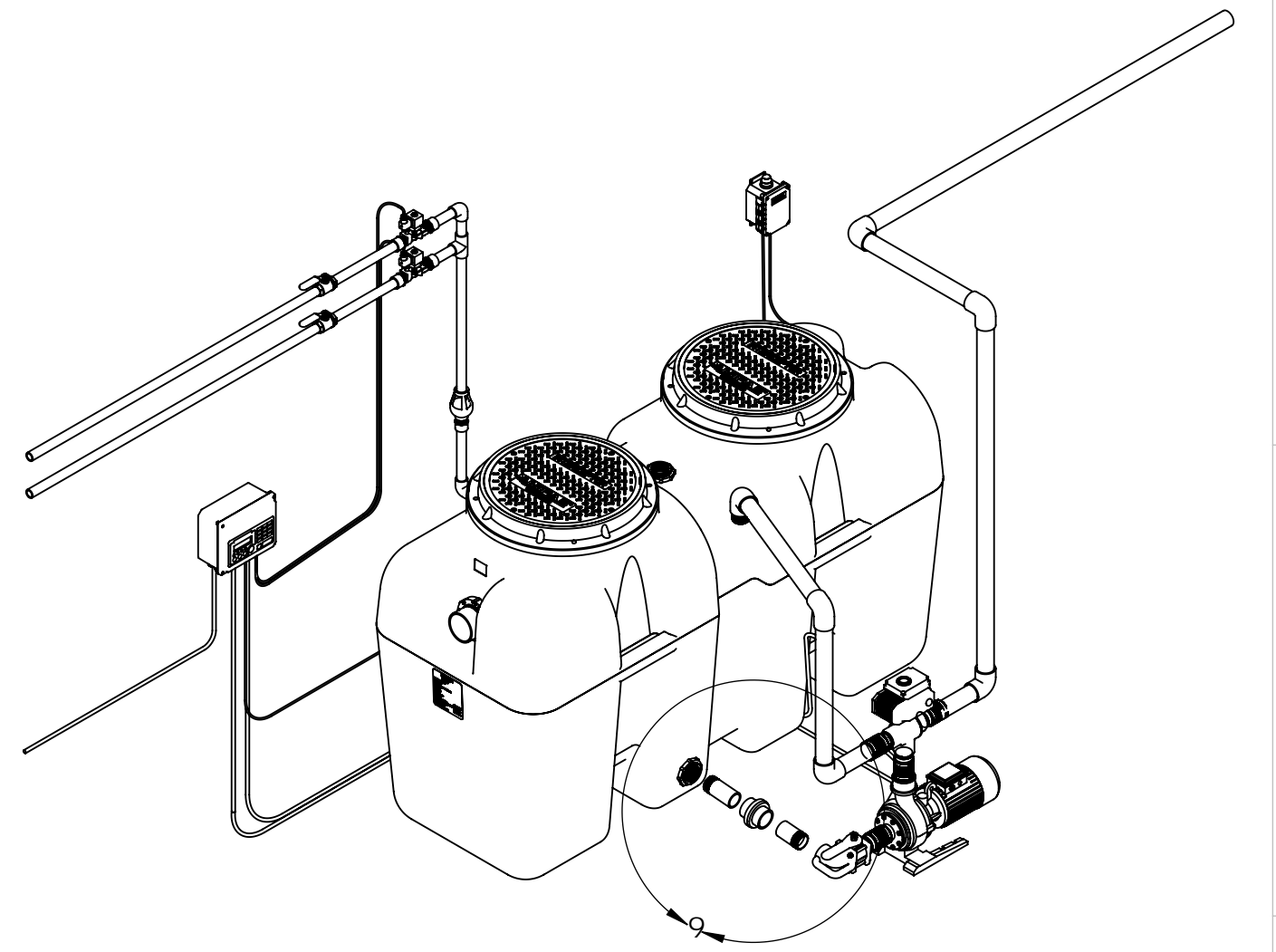

- (%) " " I G 9 ' D : H 9 ' H 5 D 9 ' C F ' H k F 9 5 8 ' G 9 5 @ B H C B H C ' H k 9 ' D @ 9 B @ D @ 9 ' H k F 9 5 8 G ' 5 B 8 ' B G H 5 @ @ B H C ' & " ' H 5 B ? ' : # H B ; " "
- (%) " " I G 9 ' D : H 9 ' H 5 D 9 ' C F ' H k F 9 5 8 ' G 9 5 @ B H C B H C ' H k 9 ' D @ 9 B @ D @ 9 ' H k F 9 5 8 G ' 5 B 8 ' B G H 5 @ @ B H C ' & " - \$ \$ G < I H C : : ' J 5 @ 9 "
- (%) " " K @ 9 ' H k 9 ' B G @ 8 9 ' C : ' H k 9 ' & " I B @ B ' 5 B 8 ' H k 9 ' C I H G @ 8 9 ' C : ' H k 9 ' D @ 9 ' K # k ' D J 7 ' D F A 9 F " ' 5 : H 9 F ' 5 6 C I H % \$ ' G 9 7 C B 8 G z
G D F 9 5 8 ' 5 B ' 9 J 9 B ' @ 5 M 9 F ' C : ' G C @ 9 B H D J 7 ' 7 9 A 9 B H C B ' H k 9 ' B G @ 8 9 ' C : ' H k 9 ' I B @ B ' 5 B 8 ' H k 9 ' C I H G @ 8 9 ' C : ' H k 9 '
D @ 9 " D I G < ' H k 9 ' D @ 9 ' B H C ' H k 9 ' I B @ B ' 7 C B B 9 7 H C B " D F 9 G G 5 B 8 ' < C @ B ' H k 9 ' D @ 9 ' : C F ' 5 6 C I H %) ' G 9 7 C B 8 G : C F '
5 ' G H C B ; ' 7 C B B 9 7 H C B "
- (%) " " " B G H 5 @ @ H k 9 ' & " G D F 5 M 9 F ' D @ 9 ' 5 G G 9 A 6 @ M H C ' H k 9 ' & " G K # 7 < ' J 5 @ 9 ' 5 G G 9 A 6 @ M
- (%) " " " 7 C B B 9 7 H H k 9 ' & " 8 @ D C G 5 @ D @ 9 ' H C ' H k 9 ' C D 9 B ' B C ! < I 6 ' 7 C B B 9 7 H C B ' C B ' H k 9 ' & " G K # 7 < ' J 5 @ 9 ' 5 G G 9 A 6 @ M

B C H 9 : 8 C ' B C H I G 9 ' D : H 9 ' H 5 D 9 ' C F ' H k F 9 5 8 ' G 9 5 @ 5 B H C B ' H k 9 ' I B @ B ' H k F 9 5 8 G '

D F C D F @ 4 B F M 5 B 8 7 C B : @ 9 B H 5 @
H 9 B : C F A 5 H C B 7 C B H 5 B 9 8 B H k G
B F 5 K B : G H 9 C C @ 9 D F C D P H M C :
A = 5 6 2 B 7 " 5 B M F 9 D F C 8 I 7 H C B B
D 5 F H C F 5 G 5 K < C @ 9 K # k C I H H k 9
K F H H B D 9 F A 4 G C B C : A = 5 6 2 B 7 " G
D F C < 6 4 9 8 "

@ G 9 F # G < 9 5 F .	I B @ 9 C C H : 9 F K @ 9 D 9 7 @ 9 8 .	B 5 A 9	B 5 H 9	
6 F 5 ? 9 D F 9 G G	8 A 9 8 G C B G 5 F 9 B @ 7 < 9 G H C @ 9 F 5 B 7 9 G : F 5 7 H C B 5 @ 9 9 9 9 5 B : 1 @ 5 F ' A 5 7 < @ 9 6 9 8 B @ 9 H k C D @ 5 7 9 B 9 7 A 5 @ 9 2 5 9 H k F 9 9 D @ 5 7 9 B 9 7 A 5 @ 9 2 5 9 H D 7 5 @ 9 8 F 5 : H 5 B : @ 9 & "	8 F 5 K B	A A	
K 9 @ 9 8 ' 6 M	A 5 H F 5 @ 9 8 6 7 F @ 9 H C B G 9 9 I 6 C A	7 < 9 7 9 8	LL	H H @ 9 % \$ \$: D A < 8 D 9 ; F G B H # 9 8 \$ @ G ; F G < @ 7 5 D " G 9 @ ! 7 @ 9 5 B @ B ; ' G M G H 9 A
7 @ 9 5 B # D 5 B H		9 8 : 5 D D F "		
7 C A D @ 9 H 8 ' 6 M		A : : 5 D D F "		
F 9 J @ 9 K 9 8 ' 6 M		E " 5 "		
B 9 L H 5 G G M	I G 9 8 C B	E I 5 B H M		
5 D D @ 7 5 H C B				
	8 C B C H G 7 5 @ 9 8 F 5 K B :			
		G 9 9 ! D C		
		G N 9	8 K ; " " B C "	F 9 J
		7	6 7 ! 9 8 9 \$! G 7	
		G 7 5 @ 9 . % & (K 9 # < H ' ;		G < 9 9 H * C : *