

Location: _____



R1220-R

**MEDIUM SUMP ROOF DRAIN
WITH INTEGRAL 2" WATER DAM**

Specification: MIFAB® Series R1220-R lacquered cast iron medium sump roof drain with 12" diameter anchor flange, 2" high cast iron integral combined water dam and waterproofing membrane clamp ring, and standard self-locking cast iron dome strainer with a free area of 71.50 square inches.

Function: Used in flat roofs where a constant height of water is required. Also used as an emergency overflow, draining water when the depth of the water on the roof exceeds the water dam height. Large free area dome provides for efficient drainage of rainwater and prevents debris from entering the drain line. Extra wide anchor flange and membrane clamp provides for secure grip of membrane and roof flashing materials.

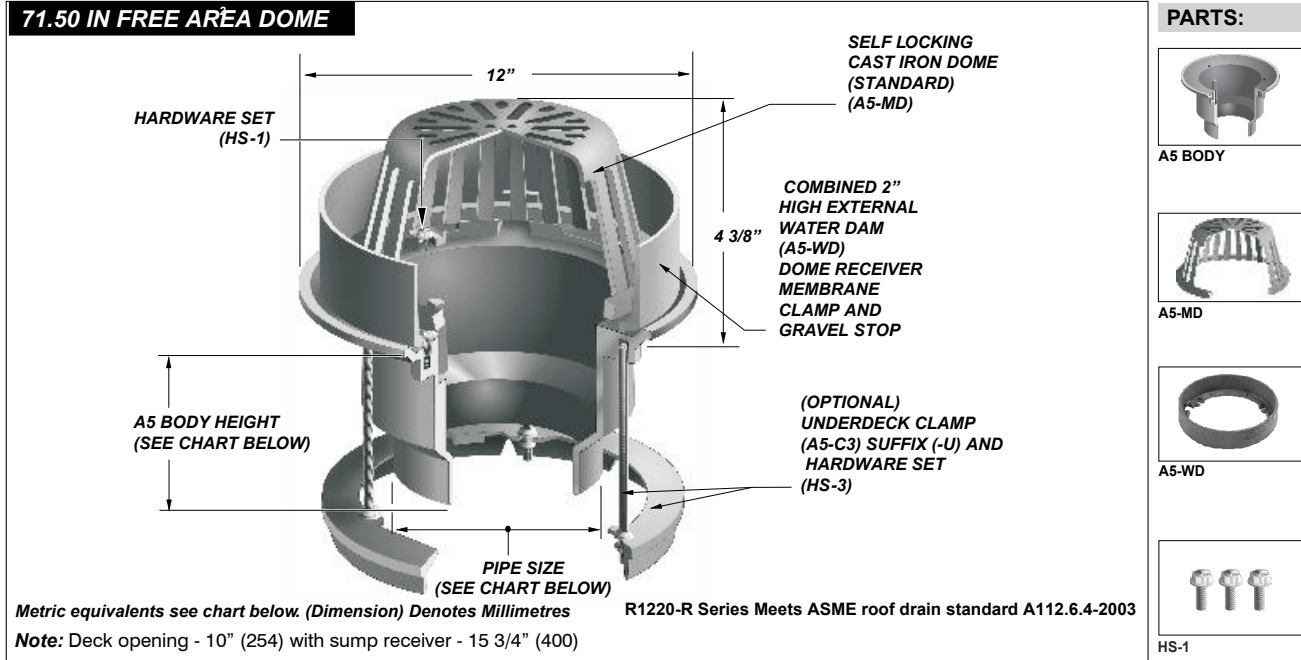

PIPE SIZE	BODY HEIGHT	
	NO HUB (STANDARD)	INSIDE CAULK (X)
2" (51)	6 1/2" (165)	6.575 (167)
3" (76)	6 1/2" (165)	6.575 (167)
4" (102)	6 1/2" (165)	6.575 (167)
6" (152)	6 1/2" (165)	6.575 (167)

SUFFIX	OPTIONAL VARIATIONS	SUFFIX	OPTIONAL VARIATIONS
-6	Vandal proof dome (metal dome only)	-EG	Galvanized Adjustable extension
-11	Acid resistant epoxy coating	-G	Stainless steel ballast guard
-12	Galvanized metal dome	-HC	Adj. ballast guard with secondary clamp
-12A	Galvanized body and membrane clamp	-JC	S.S. ballast guard with secondary clamp
-13	Galvanized body, membrane clamp and dome	-PA	Pennsylvania Steel Act compliant product
-83	Stainless steel mesh screen over dome	-U	Underdeck clamp
(Standard)	No hub outline	-U3	Underdeck clamp with cutaway side
-B	Sump receiver	-W-1	Water proofing flange
-BA	Buy America Act compliant product	X	Inside caulk outlet (2",3",4")
-C	Secondary clamp	-XJ	Vertical expansion joint (see R1900)
-E	Adjustable extension	-Z	Extended wide elastomeric flange (20" diameter x 1/4" thick)

CALIFORNIA PROPOSITION 65 WARNING. This product contains chemicals known to the State of California to cause cancer and birth defects or other reproductive harm.

Job Name: _____ Page No: _____

Section No: _____ Contractor: _____

Schedule No: _____ Purchase Order No: _____