

Location: _____



P6150

1 1/2" Wide, Stainless Steel Frame and Grate System

SPECIFICATION:

MIFAB® Series P6150, 1 1/2" wide, Load Class "A" Light duty slotted trench drain ADA compliant grate constructed of Type 304 stainless steel with 10 gauge stainless steel angle frame and anchor tabs. Free area of 2.0 square inches per 1' section. Also available with B, C, D and E load rated stainless steel grates and optional anchor flange (Suffix -FL).

FUNCTION:

Used in front of walk in coolers, barrier free showers and industrial, commercial, kitchen and other hygienic areas. Type 304 stainless steel construction provides for ease of cleaning, maintenance and sanitary installation. All grate openings are polished to a smooth finish.

Note: Every order of this product is a special / custom order fabrication. This product is non returnable and noncancellable.

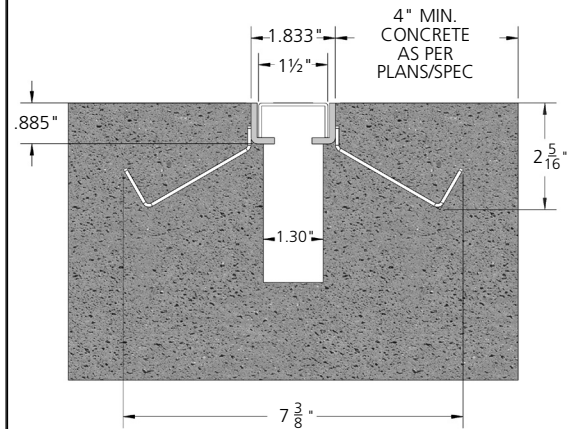

Specifying engineer is responsible for concrete encasement and reinforcing based upon application and local codes.

MODEL NUMBER	DESCRIPTION
P6150	1 1/2" wide, Type 304 Stainless Steel Frame and Grate System (Load Class "A", "Light Duty" ADA compliant grates)
P6150-29	1 1/2" wide, Type 316 Stainless Steel Frame and Grate System (Load Class "A", "Light Duty" ADA compliant grates)

OPTIONAL VARIATIONS	DESCRIPTION
Length	Specify the length that is required
-LCB	Load Class "B", Medium Duty Grate (2,000 - 4,999 lbs.)
-LCC	Load Class "C", Heavy Duty Grate (5,000 - 7,499 lbs.)
-LCD	Load Class "D", Extra Heavy Duty Grate (7,500 - 10,000 lbs.)
-LCE	Load Class "E", Special Duty Grate (over 10,000 lbs.)
-LS	Longitudinal Slotted Grate (ADA Compliant)
-NS	Slip Resistant Grate (Non slip grit finish)
-PG	Perforated Grate (1/4" diameter holes)
-PHP	Perforated "Heel Proof Grate" (less than 1/4" diameter perforations)
-SHP	Slotted "Heel Proof" Grate (less than 1/4" wide slots)
-6	Vandal Resistant Grate
-90	90 Degree Section

CALIFORNIA PROPOSITION 65 WARNING. This product contains chemicals known to the State of California to cause cancer and birth defects or other reproductive harm.

Job Name: _____ Page No: _____
 Section No: _____ Contract: _____
 Schedule No: _____ Purchase Order No: _____