

1 REMOVE SCREWS AND RUBBER WASHERS

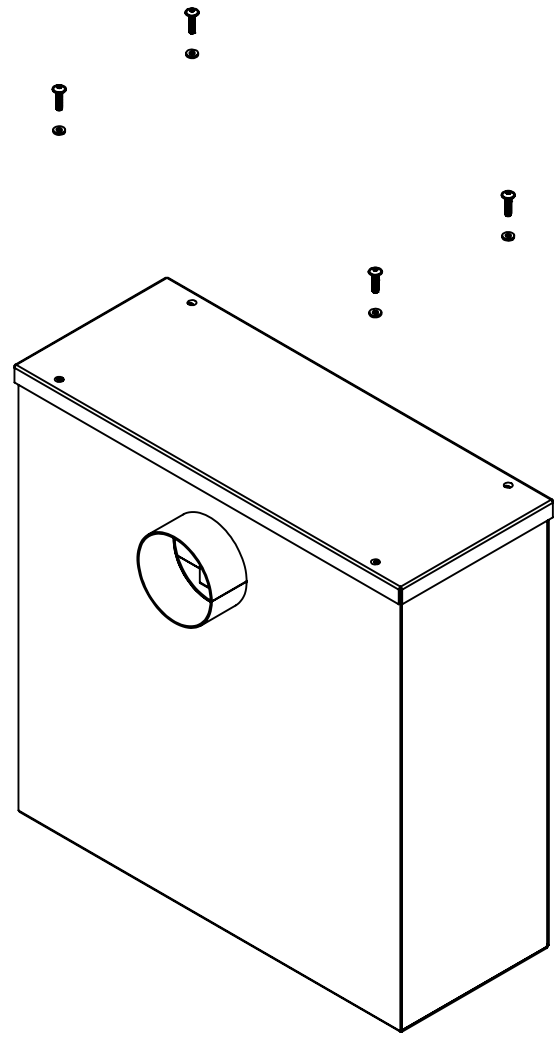

2 REMOVE LID

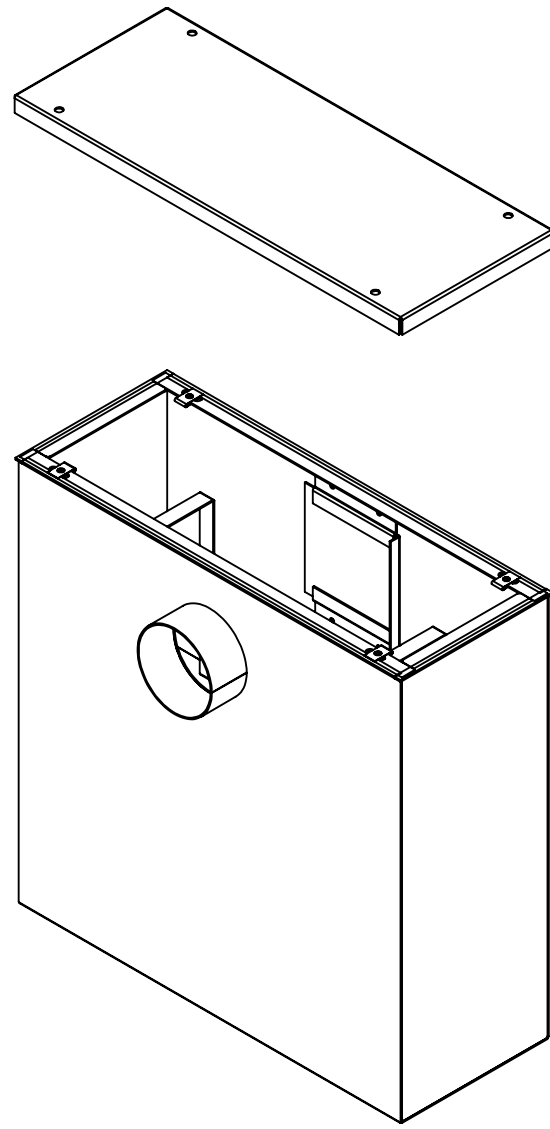

3 REMOVE CLIPS FROM TOP FLANGE

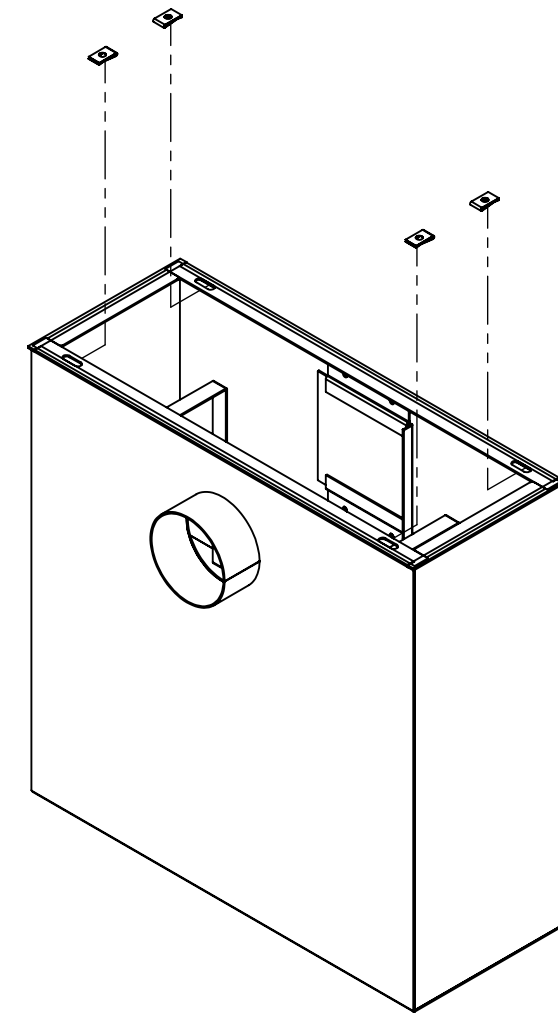

4 REMOVE SEDIMENT BUCKET AND CLEAN THOROUGHLY REMOVING LOOSE SOLIDS AND DEBRIS FROM SEDIMENT BUCKET AND FROM INSIDE OF INTERCEPTOR

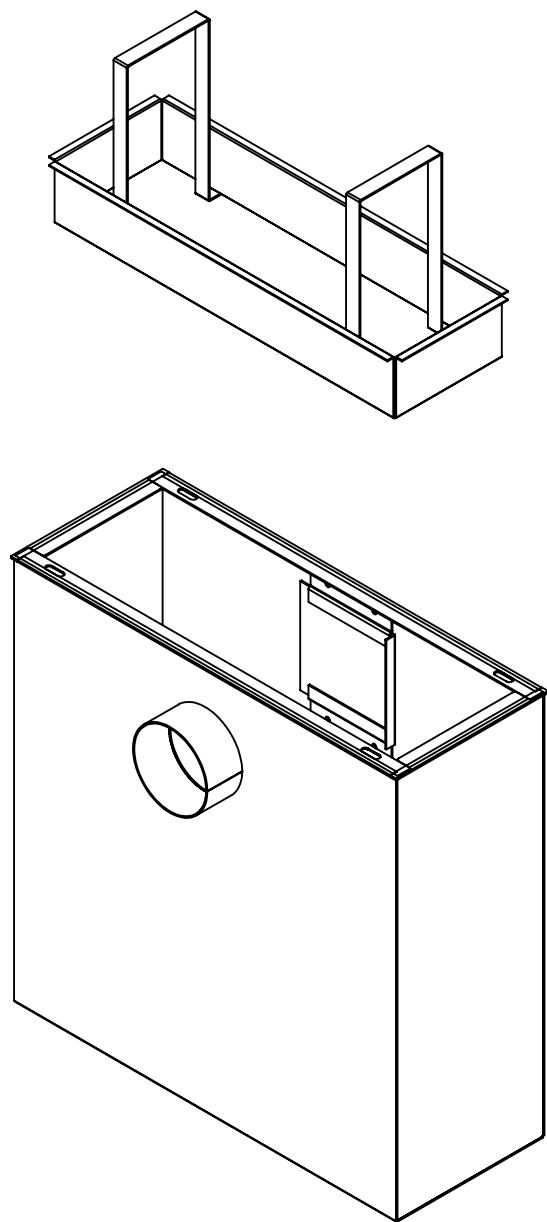

5 REMOVE OUTLET SCREEN AND CLEAN

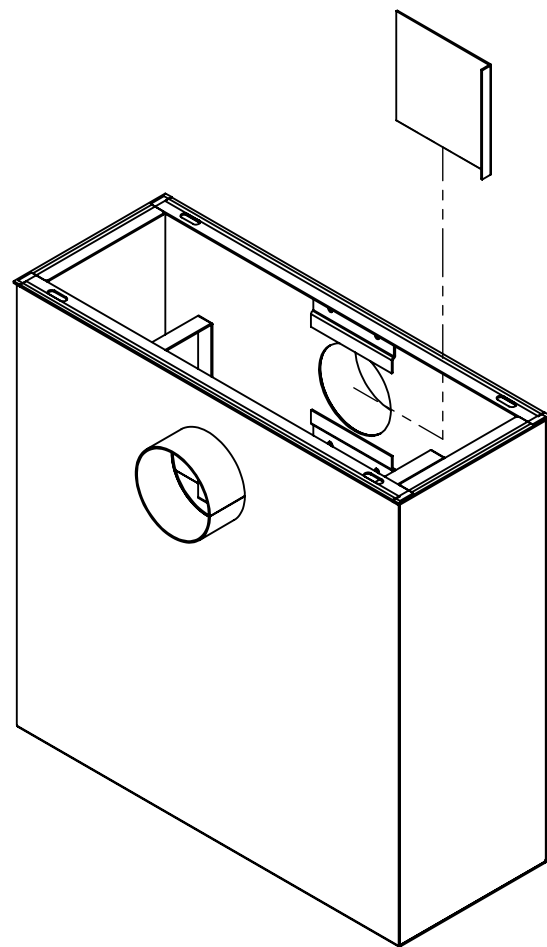

6 REASSEMBLE

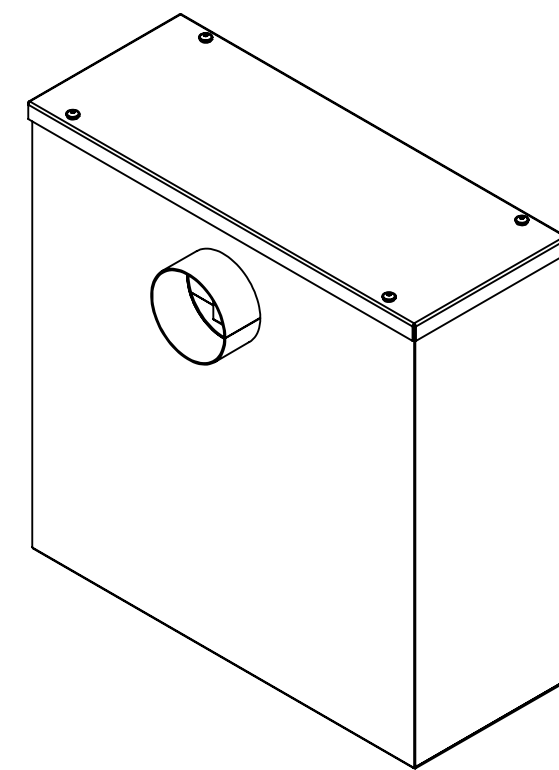

PROPRIETARY AND CONFIDENTIAL
 THE INFORMATION CONTAINED IN THIS DRAWING IS THE SOLE PROPERTY OF <INSERT COMPANY NAME HERE>. ANY REPRODUCTION IN PART OR AS A WHOLE WITHOUT THE WRITTEN PERMISSION OF <INSERT COMPANY NAME HERE> IS PROHIBITED.

UNLESS OTHERWISE SPECIFIED: DIMENSIONS ARE IN INCHES TOLERANCES: FRACTIONAL ±1/16 ANGULAR: MACH ±1° BEND ±1° TWO PLACE DECIMAL ±.015 THREE PLACE DECIMAL ±.010 TYPICAL DRAFT ANGLE 2°		DRAWN	NAME	DATE
		CHECKED	RL	5/3/2013
		ENG APPR.		
		MFG APPR.		
		Q.A.		
		QUANTITY:		
NEXT ASSY	USED ON	FINISH	XXXXXXX	
APPLICATION		DO NOT SCALE DRAWING		



TITLE:
MAINTENANCE PROCEDURE

SIZE DWG. NO. REV
C MI-SOLID-TA
 SCALE: 1:4 WEIGHT: SHEET 1 OF 1