

Location: _____



MC-62

FLOOR MOUNTED SERVICE SINK CARRIER WITH FITTING

Specification: MIFAB® Series MC-62 floor mounted service sink carrier with two lacquered 2" x 1" x 1/8" thick structural steel uprights with 3" x 4 1/2" welded steel feet, and lacquered cast iron fitting with no hub waste and vent connection (specify size of each). Complete with lacquered cast iron faceplate assembly, adjustable 8" tapered thread ABS nipple with integral test cap, neoprene bowl gasket, hardware, threaded rod protectors and polished chrome plated finishing cap nuts.

Function: Used with off the floor wall urinals and service sinks that are wall mounted and have no contact with the finished floor. Typically installed in utility, emergency and clean-up rooms. The closet carrier and fitting is completely concealed within the wall and supports the load of the fixture through a faceplate and foot support system that is anchored to the floor. Sanitation underneath the fixture is more efficiently and economically maintained when installed off of the floor compared to floor mounted.

Note: Foot supports and faceplate are assembled at the factory before shipment in the typical siphon jet water closet configuration and are reversible for the blowout water closet design.

"X" = 4 5/8" MIN, 5 3/4" MAX, WITH STANDARD NIPPLE. 1 1/4" IS POSSIBLE WITH SHORTENED NIPPLE. FOR GREATER THAN STANDARD MAX, USE LONGER NIPPLES AND SPECIFY DIMENSION REQUIRED.

UNIVERSAL PLATE ASSEMBLY SECURED TO UPRIGHTS

"U" BOLTS TO SECURE UNIVERSAL PLATES TO UPRIGHT

FACEPLATE MOUNTING BRACKETS

EXTRA HEAVY DUTY RECTANGULAR STEEL STRUCTURAL UPRIGHTS

HEAVY DUTY WELDED FEET THAT FIT WITHIN STANDARD STUD WALL CONSTRUCTION

Dimensions: 22", 36", 3", 4 1/2"

MC-62 Series Meets ANSI/ASME fixture carrier standard A112.6.1M-97

NOTE: Blow-out configuration illustrated; for Siphon Jet, invert face plate.

NOTE: See the various fixture dimensional rough-in guides on the www.mifab.com website.

Note: 8" tapered thread ABS nipple shipped standard with MC-10 Series carriers. The universal faceplate assembly accepts all nipple variations, rolling thread (-OR), cast iron (-CI) and tapered thread ABS with adjustable horn (-AH).

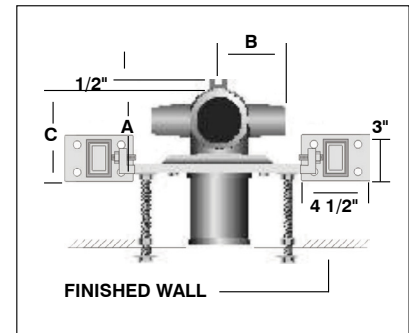

MODEL NUMBER	A	B	C
MC-62-3-V2	4 3/4" (89)	5 1/2" (140)	5 7/8" (125)
MC-62-4-V2	4 7/8" (100)	5 1/2" (140)	7" (156)
MC-62-4-V4	4 7/8" (100)	5 1/2" (140)	7" (156)

MODEL NUMBER CHART	
MC-62-3-V2	- 3" waste fitting, 2" vent
MC-62-4-V2	- 4" waste fitting, 2" vent
MC-62-4-V4	- 4" waste fitting, 4" vent

SUFFIX	OPTIONAL VARIATIONS
-AH8	8" ABS nipple with adjustable horn
-AH12	12" ABS nipple with adjustable horn
-BA	Buy American Act compliant product
-CI-4	4" rolling thread cast iron nipple
-CI-6	6" rolling thread cast iron nipple
-CI-8	8" rolling thread cast iron nipple
-CI-12	12" rolling thread cast iron nipple
-CI-24	24" rolling thread cast iron nipple
-HD	Heavy duty 500 lb. load rated carrier
-HD-750	750 lb. rated heavy duty
-HDX	1,000 lb. rated extra heavy duty
-OR8	8" rolling thread ABS nipple
-OR12	12" rolling thread ABS nipple
-PA	Pennsylvania Steel Act compliant product
-PFAB	Prefabricated carrier

-V2	2" no hub vent connection
-V4	4" no hub vent connection
-3	3" no hub waste connection
-4	4" no hub waste connection
-10	Auxiliary support, recommended with nipple lengths over 12"
-12	12" tapered thread ABS nipple
-13	Galvanized cast iron
-14	Vandal proof finish trim
-17	Test plug for custom cast iron nipples
-19	Nipple wrench
-20	Flush valve support
-25	2" Auxiliary inlet, right side
-26	2" Auxiliary inlet, left side
-31	Two 2" Auxiliary inlets
-32	Foot pedal valve mounting plate

CALIFORNIA PROPOSITION 65 WARNING. This product contains chemicals known to the State of California to cause cancer and birth defects or other reproductive harm.

Job Name: _____ Page No: _____

Section No: _____ Contractor: _____

Schedule No: _____ Purchase Order No: _____