

Location: _____



MC-200

MC-14 AND MC-15 FACEPLATE / LEG ASSEMBLY

Specification: MIFAB® MC-200 lacquered cast iron faceplate / leg assembly for MIFAB's MC-14/15 series of fixture carriers. Standard with zinc plated hardware, ABS waste coupling and chrome plated finish cap nuts.

Function: Used to connect to MIFAB's MC-14 /15 fixed vertical fixture carriers. The toilet is supported off the floor by this carrier so that the maintenance team can easily clean underneath the toilet for a sanitary application.

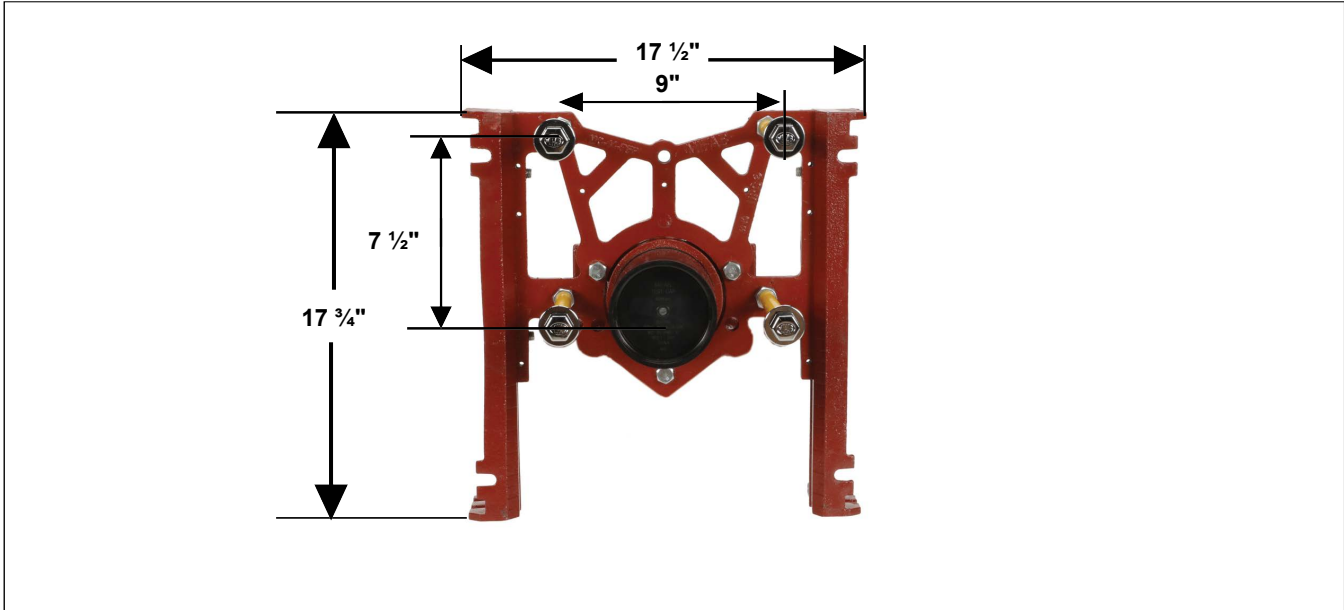

PART NO.	DESCRIPTION	WEIGHT (LBS.)
MC-200	Faceplate/leg assembly for MC-14 and MC-15 fixture carriers	33.00

CALIFORNIA PROPOSITION 65 WARNING. This product contains chemicals known to the State of California to cause cancer and birth defects or other reproductive harm.

Job Name: _____ Page No: _____
Section No: _____ Contractor: _____
Schedule No: _____ Purchase Order No: _____