

Location: _____



MC-15D-HS

DOUBLE FIXED VERTICAL HUB AND SPIGOT WATER CLOSET CARRIER OFFSET FROM STACK

Specification: MIFAB® Series MC-15D-HS double, hub and spigot, vertical, fixed water closet carrier with offset lacquered cast iron fitting, 4" (102) waste, 2" (51) vent connection, lacquered cast iron gasketed adjustable faceplates, universal floor mounted cast iron foot supports, adjustable 8" tapered thread ABS nipples with integral test caps, neoprene bowl gaskets, hardware, threaded rod protectors and polished chrome plated finishing cap nuts.

Function: Used with back to back water closets that are offset from a common stack by 4" in multi-floor installations where minimum pipe space is required. Typical for off the floor plumbing fixtures that are wall mounted and have no contact with the finished floor. The closet carrier is completely concealed within the wall and supports the load of the fixture through a faceplate and foot support system that is anchored to the floor. Sanitation underneath the fixture is more efficiently and economically maintained when installed off of the floor compared to floor mounted.

Note: 9 1/4" (235) minimum space required between front of foot supports.

Note: Foot supports and faceplate are assembled at the factory before shipment in the typical siphon jet water closet configuration and are reversible for the blowout water closet design.

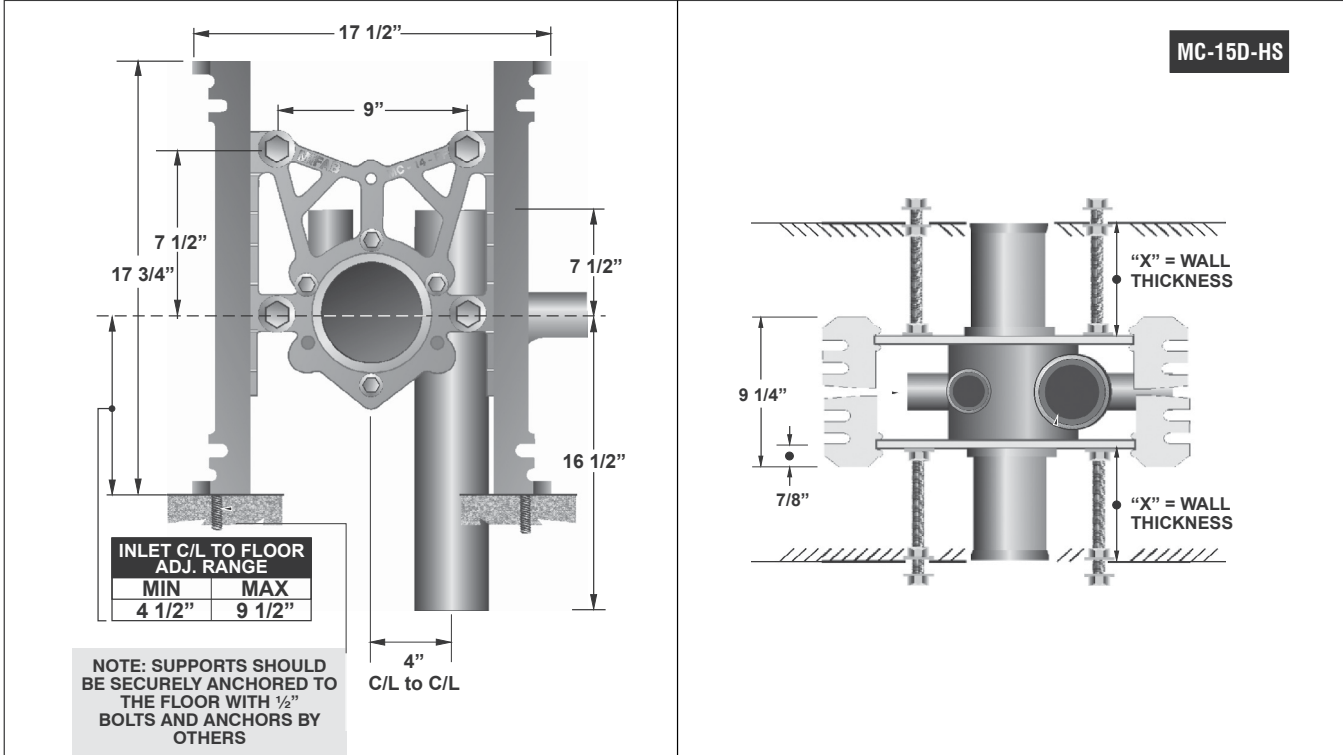

*MC-15 is tested to support a 500 lb. load with the rear anchor support.

Note: 8" tapered thread ABS nipple shipped standard with MC-15 Series carriers. The universal faceplate assembly accepts all nipple variations, rolling thread (-OR), cast iron (-CI) and tapered thread ABS with adjustable horn (-AH).

MODEL NO.	DESCRIPTION
MC-15D-HS	Double - back to back offset

SUFFIX	OPTIONAL VARIATIONS
-AH8	8" ABS nipple with adjustable horn
-AH12	12" ABS nipple with adjustable horn
-BA	Buy American Act compliant product
-CI-4	4" rolling thread cast iron nipple
-CI-6	6" rolling thread cast iron nipple
-CI-8	8" rolling thread cast iron nipple
-CI-12	12" rolling thread cast iron nipple
-CI-24	24" rolling thread cast iron nipple
-FM	Floor mount, back outlet fixture support
-HD-750	750 lb. rated heavy duty
-HDX	1,000 lb. rated extra heavy duty
-OR8	8" rolling thread ABS nipple
-OR12	12" rolling thread ABS nipple
-PA	Pennsylvania Steel Act compliant product

-PFAB	Prefabricated carrier
-01	Neoprene bowl gasket
-1	Finishing / Tiling frame
-10	Auxiliary support, recommended with nipple lengths over 12"
-12	12" tapered thread ABS nipple
-13	Galvanized cast iron
-14	Vandal proof finish trim
-17	Test plug for custom cast iron nipples
-19	Nipple wrench
-20	Flush valve support
-22	Less fitting
-25	2" Auxiliary inlet, right side
-26	2" Auxiliary inlet, left side
-31	Two 2" Auxiliary inlets

CALIFORNIA PROPOSITION 65 WARNING. This product contains chemicals known to the State of California to cause cancer and birth defects or other reproductive harm.

Job Name: _____
 Section No: _____
 Schedule No: _____

Page No: _____
 Contractor: _____
 Purchase Order No: _____