

Location: _____



F1860

LARGE PLANTING AREA DRAIN WITH 8" HIGH PERFORATED STANDPIPE AND DOME

Specification: MIFAB® Series F1860 12" square open top drain with lacquered cast iron body and loose set ductile iron bottom grate.

Function: Used in areas that are not traffic prone to provide drainage of water from objects placed into the hopper.

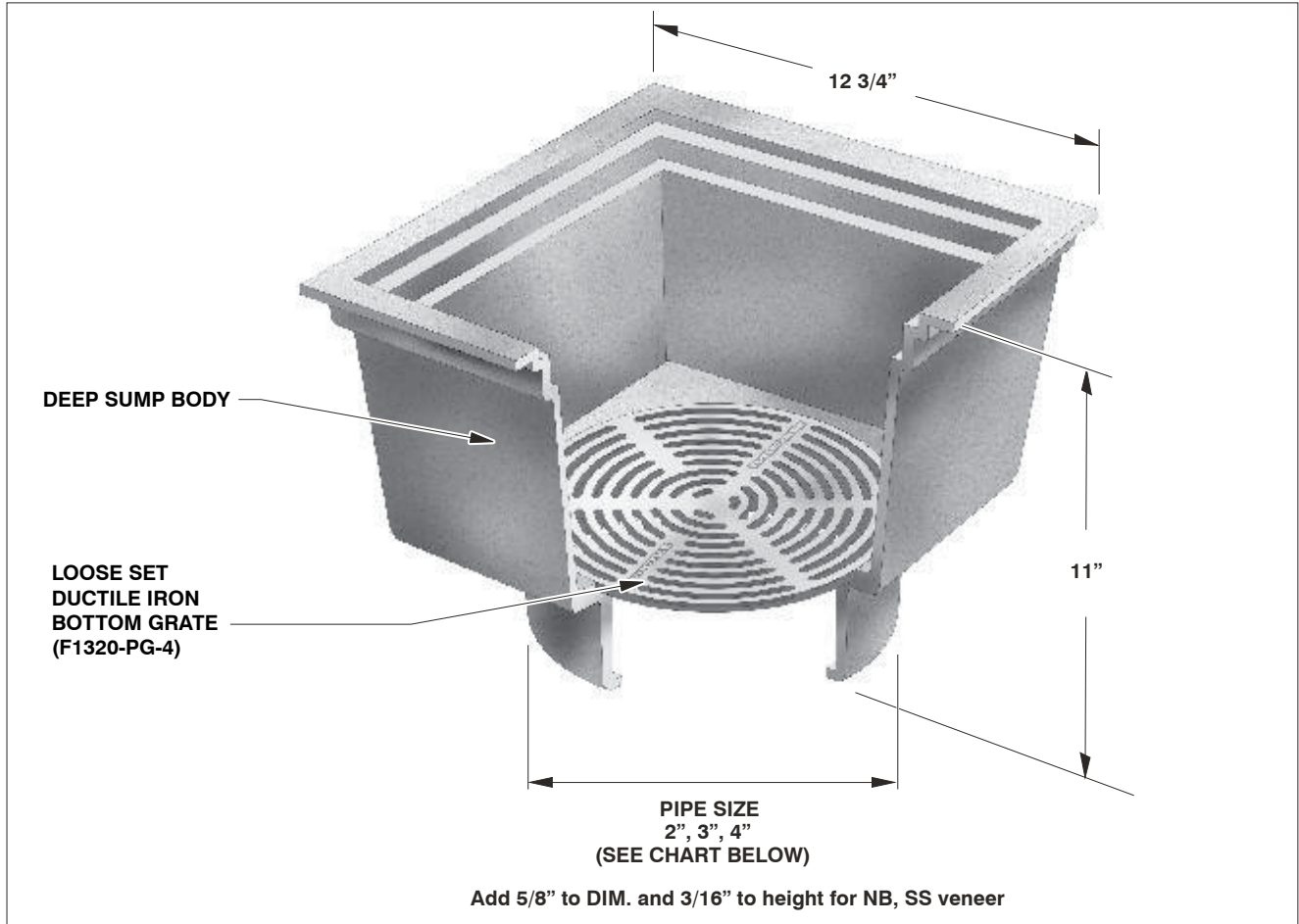

PIPE SIZE	BODY HEIGHT
	NO HUB (STANDARD)
2" (51)	11" (279)
3" (76)	11" (279)
4" (102)	11" (279)

SUFFIX	OPTIONAL VARIATIONS
-5	Sediment bucket
-11	Acid resistant epoxy coated body
-13	Galvanized body
-16-1	Nickel bronze floor level square grate (vener)
-16-3	Stainless steel floor level square grate (vener)
-16-4	Ductile iron floor level square grate
-21	Secondary flat stainless steel strainer (2", 3", 4")

SUFFIX	OPTIONAL VARIATIONS
-BA	Buy American Act compliant product
-FL	Anchor flange
-FLC	Anchor flange and membrane clamp
(Standard)	No hub outlet
-MG	MI-GARD Floor Drain Trap Sealer (2", 3" or 4")
-PA	Pennsylvania Steel Act compliant product

Job Name: _____ Page No: _____
 Section No: _____ Contractor: _____
 Schedule No: _____ Purchase Order No: _____