

Location: _____



F1590-90

**24" X 24" HEAVY DUTY PARKING
AREA DRAIN WITH SIDE OUTLET**

Specification: MIFAB® Series F1590-90 powder epoxy coated parking area drain with side outlet, anchor flange, and extra heavy duty 24" x 24" (610 x 610) two section ductile iron grates with a free area of 200 square inches (129,032²). Grates to have maximum 13/16" (21) openings.

Function: Used in industrial factories, mechanical rooms, parking garages and other membrane finished areas. 24" x 24" tractor grate is used with all types of poured finished floors. The anchor flange provides maximum support for drain.

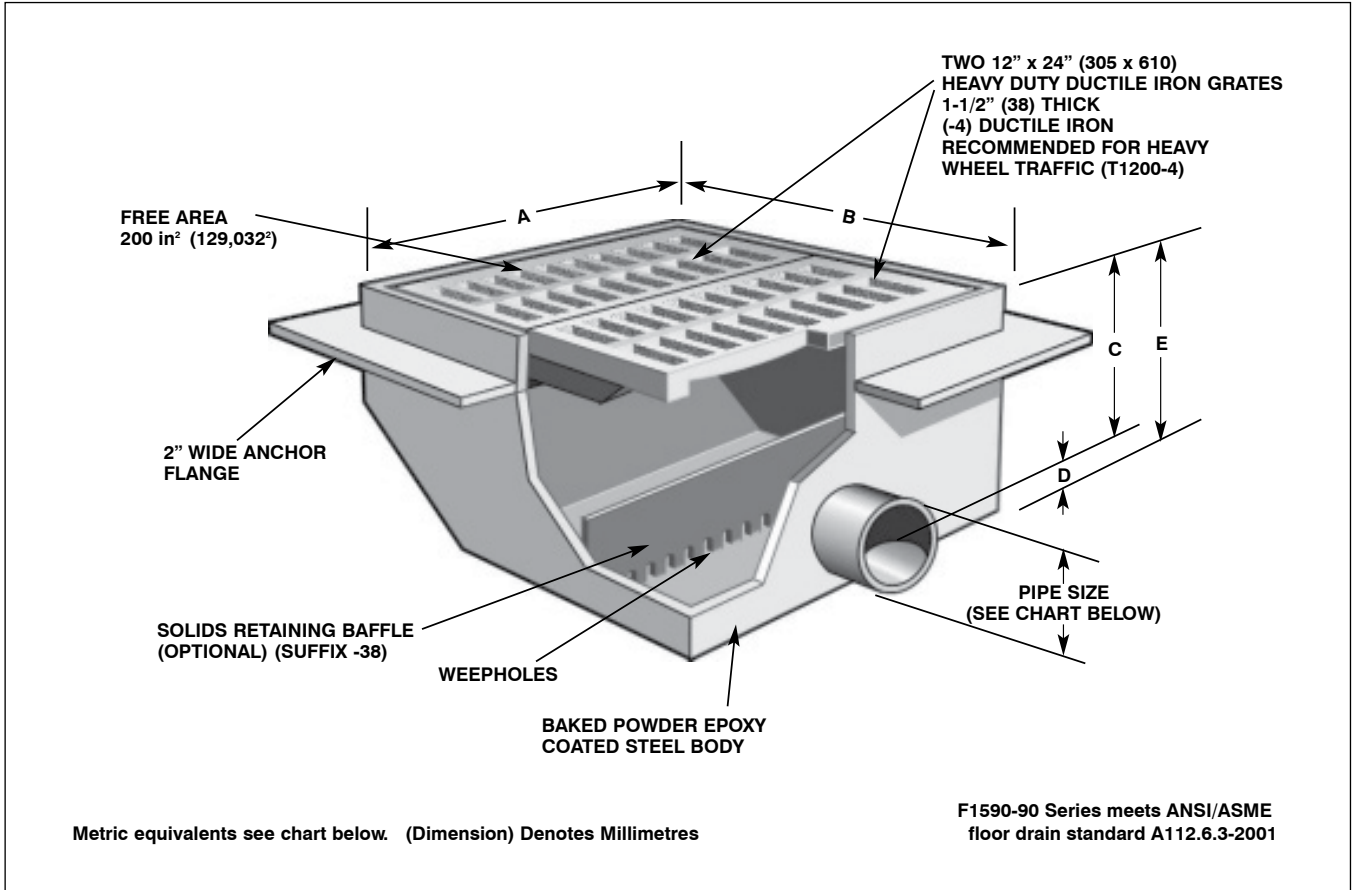

MODEL NO.	NO HUB PIPE SIZE	BODY DIMENSIONS				
		(A)	(B)	(C)	(D)	(E)
F1590-90	2" (51)	24 ½" (622)	24 ½" (622)	16 ½" (419)	5 ½" (140)	22" (559)
	3" (76)					
	4" (102)					
	6" (152)					

SUFFIX	OPTIONAL VARIATIONS
-3	Stainless steel strainer (vener)
-4	Ductile iron strainer
-6	Security screws (T-20 Torx & pin)
-8	Backwater valve (2", 3", 4")
-12	Galvanized top assembly
-13	Galvanized body

-28	Stainless steel body and grate (Type 304)
-38	Solids retaining baffle
-BA	Buy American Act compliant product
-C	Membrane clamp
-MG	MI-GARD Floor Drain Trap Sealer (2", 3" or 4")
-PA	Pennsylvania Steel Act compliant product
(Specify)	Special outlet size

CALIFORNIA PROPOSITION 65 WARNING. This product contains chemicals known to the State of California to cause cancer and birth defects or other reproductive harm.

Job Name: _____ Page No: _____
 Section No: _____ Contractor: _____
 Schedule No: _____ Purchase Order No: _____