

Location: _____



F1560

HEAVY DUTY DRAIN WITH INTERNAL TRAP

Specification: MIFAB® Series F1560 extra heavy duty lacquered area drain with side outlet body, internal deep seal trap and cleanout, seepage pan, standard 1" (25) thick, 12" (305) square heavy (specify material finish) hinged grate and suspended sediment bucket.

Function: Used in industrial factories, mechanical rooms, parking garages and other membrane finished areas. 12" square tractor grate is used with all types of poured finished floors. Hinged grate permits easy access to sediment bucket. The anchor flange provides maximum support for drain.

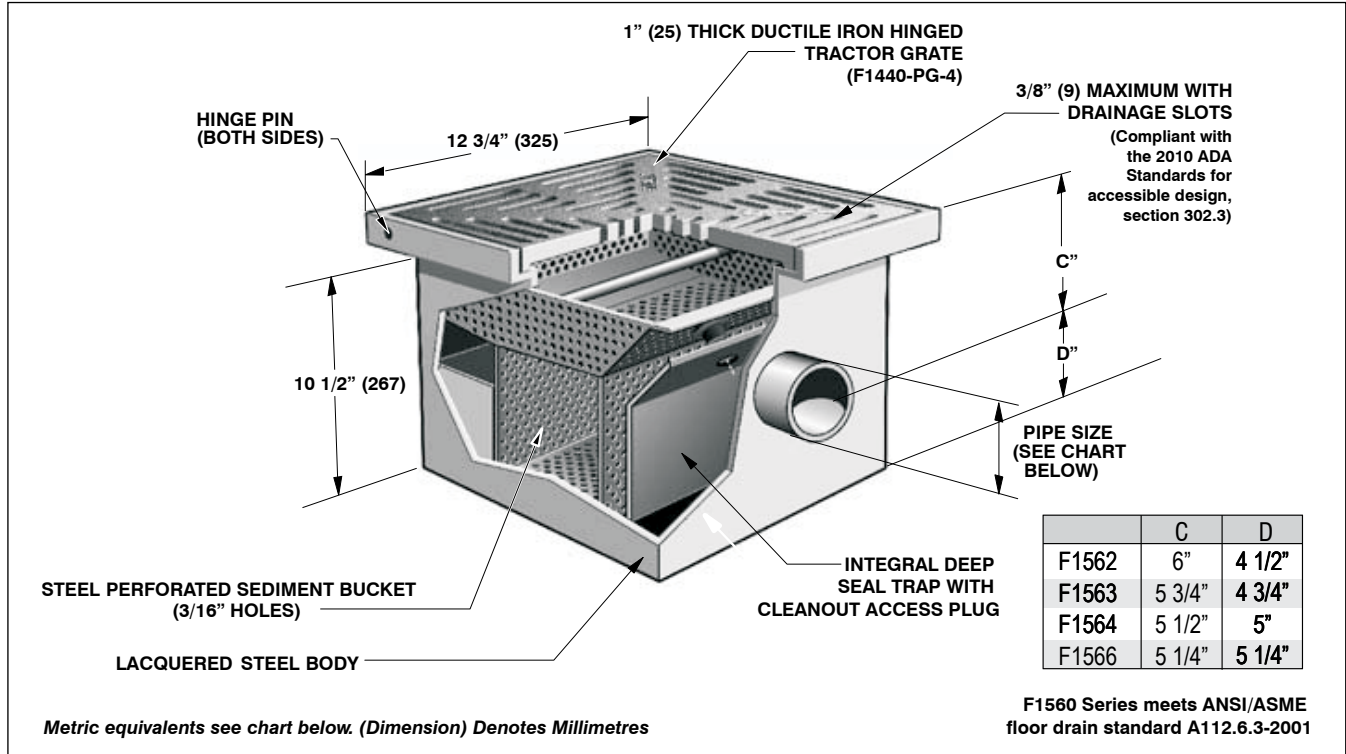

MODEL NO.	WEIGHT LBS.	GRATE SIZE	NO HUB PIPE SIZE	ANSI/ASME RATING	
				FREE AREA	LOAD RATING S.S. (-3), D.I. (-4)
F1562	116	12" x 12" (305 x 305)	2" (51)	51 in ² (32,903 ²)	ANSI/ASME LOAD CLASS "SPECIAL DUTY" (OVER 10,000 LBS.)
F1563			3" (76)		
F1564			4" (102)		
F1566			6" (152)		

SUFFIX	OPTIONAL VARIATIONS
-3	Stainless steel strainer (veneer)
-4	Ductile iron strainer
-6	Security screws (T-20 Torx & pin)
-7	1/2" trap seal primer connection
-11	Acid resistant epoxy coated body
-12	Galvanized top assembly
-13	Galvanized body
-28	Stainless steel body and grate (Type 304)

-BA	Buy American Act compliant product
-C	Membrane clamp
-FL	Anchor flange
-GS	Grounding strap
-HP	Heel proof grate (1/4" maximum grate opening size, -3 only)
-MG	MI-GARD Floor Drain Trap Sealer (2", 3" or 4")
-PA	Pennsylvania Steel Act compliant product
(Specify)	Special outlet size
(Standard)	No hub outlet

CALIFORNIA PROPOSITION 65 WARNING. This product contains chemicals known to the State of California to cause cancer and birth defects or other reproductive harm.

Job Name: _____ Page No: _____

Section No: _____ Contractor: _____

Schedule No: _____ Purchase Order No: _____