

Location: _____



F1550

FLOOR DRAIN WITH 15" ROUND HEAVY DUTY TRACTOR GRATE WITH DEEP SUMP AND HEAVY DUTY MEMBRANE COLLAR

Specification: MIFAB® Series F1550 lacquered cast iron floor drain with anchor flange, weepholes, 20" (508) diameter fixed, heavy duty membrane collar with weepholes and standard 1" (25) thick, 15" (381) round, (specify material finish) tractor grate.

Function: Used in parking garages with precast construction where core drilling or the boxing out of the drain is required. 16" round tractor grate is used with all types of poured finished floors. The wide reinforced anchor flange provides maximum support for drain.

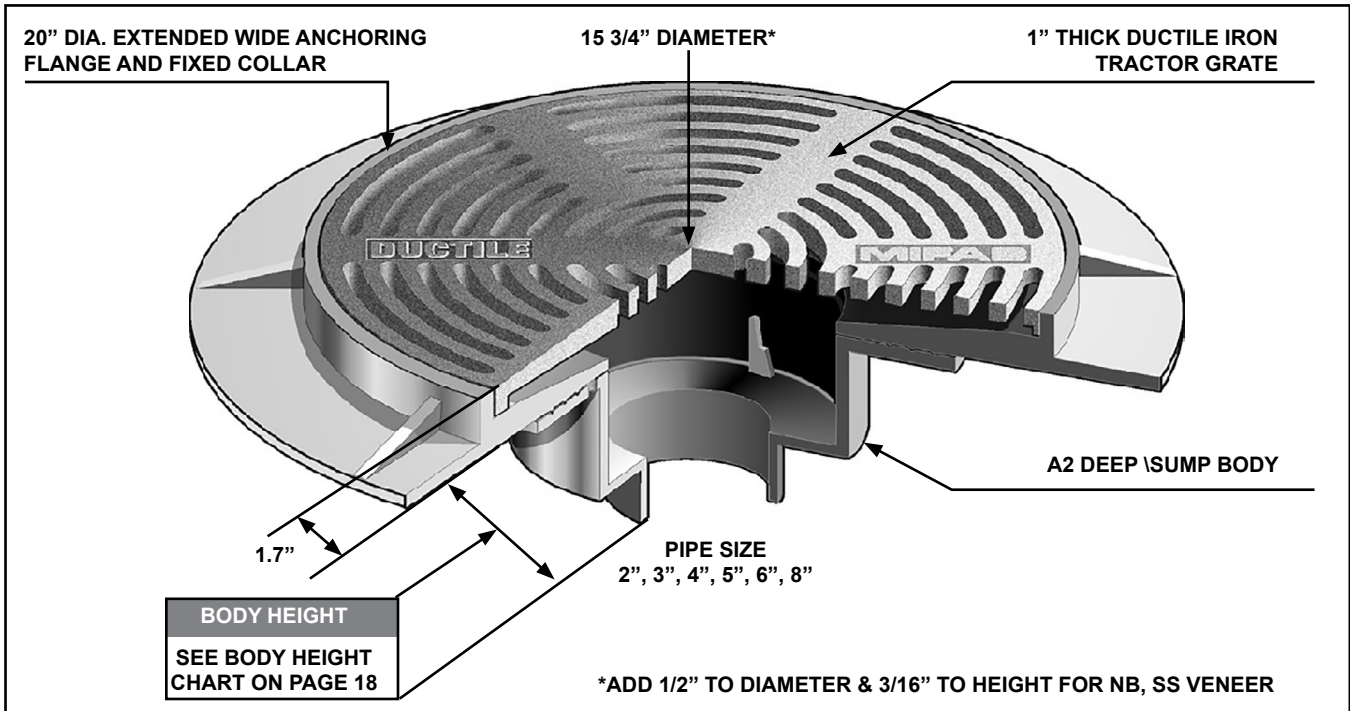

STRAINER DIAMETER	ANSI/ASME RATING		PIPE SIZE	BODY HEIGHT				
	FREE AREA	LOAD RATING N.B. (-1) / S.S. (-3) / D.I. (-4)		NO HUB (STANDARD)	PUSH ON (P)	THREADED (T)	INSIDE CAULK (X)	PVC (-30) / ABS (-31)
12 3/4" (324)	33 in ² (21,290 ²)	ANSI/ASME LOAD CLASS "SPECIAL DUTY" (OVER 10,000 LBS.)	2" (5)	6" (152)	6 1/8" (156)	5 7/16" (138)	6 1/4" (159)	7 3/8" (187)
			3" (76)	6" (152)	6 1/8" (156)	5 7/16" (138)	6 1/4" (159)	7 3/8" (187)
			4" (102)	6" (152)	6 1/8" (156)	5 7/16" (138)	6 1/4" (159)	—
			5" (127)	6" (152)	—	5 7/16" (138)	6 1/4" (159)	—
			6" (152)	7 1/4" (184)	7" (178)	7" (178)	6 1/4" (159)	7 1/8" (181)

- | SUFFIX | OPTIONAL VARIATIONS |
|--------|-----------------------------------|
| -1 | Nickel bronze strainer (vener) |
| -3 | Stainless steel strainer (vener) |
| -4 | Ductile iron strainer |
| -5 | Sediment bucket |
| -6 | Security screws (T-20 Torx & pin) |
| -7 | 1/2" trap seal primer connection |
| -8 | Backwater valve (2", 3", 4") |
| -11 | Acid resistant epoxy coated body |
| -12 | Galvanized top assembly |
| -13 | Galvanized body |
| -30 | PVC socket connection body |

- | SUFFIX | OPTIONAL VARIATIONS |
|------------|---|
| -31 | ABS socket connection body |
| -34 | Closure plug |
| -40 | Underdeck clamp |
| -90 | Threaded side outlet (2", 3", 4") |
| -90NH | No hub side outlet (2", 3", 4") |
| -BA | Buy American Act compliant product (-3 only) |
| -HP | Heel proof grate (1/4" maximum grate opening size, -3 only) |
| (Standard) | No hub outlet |
| -MG | MI-GARD Floor Drain Trap Sealer (2", 3" or 4") |
| P | Push on outlet |
| T | Threaded outlet (2", 3", 4") |
| X | Inside caulk outlet |

CALIFORNIA PROPOSITION 65 WARNING. This product contains chemicals known to the State of California to cause cancer and birth defects or other reproductive harm.

Job Name: _____
 Section No: _____
 Schedule No: _____

Page No: _____
 Contractor: _____
 Purchase Order No: _____