

Location: _____



F1510

FLOOR DRAIN WITH 12" SQUARE HEAVY DUTY TRACTOR GRATE AND DEEP SUMP

Specification: MIFAB® Series F1510 lacquered cast iron floor drain with deep sump body, wide anchor flange, weepholes, and adjustable collar with square heavy duty ductile iron hinged tractor grate with four piece surface membrane clamp, sediment bucket and free area of 51 in² (32,903²).

Function: Used in mechanical rooms, parking garages and other membrane finished areas. 12" square, adjustable tractor grate is used with all types of poured finished floors. Hinged grate permits easy access to sediment bucket. Surface membrane clamp is ideal for areas that have a surface membrane.

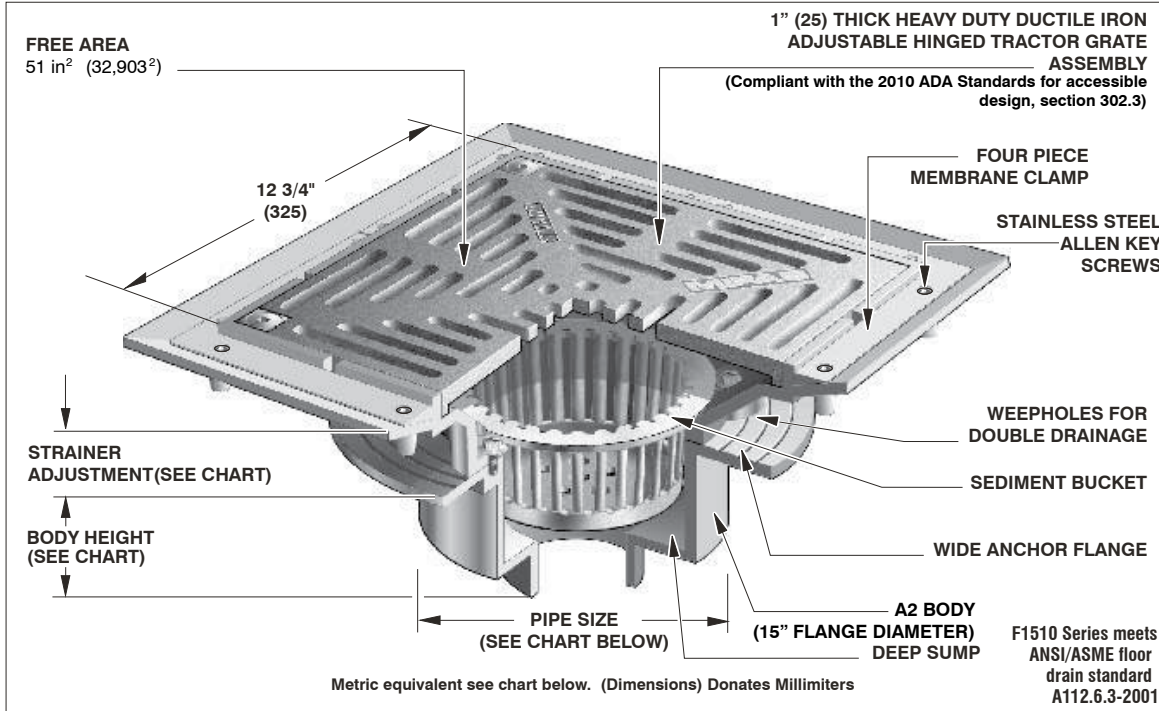

STRAINER DIAMETER	STRAINER ADJUSTMENT		FREE AREA	ANSI/ASME RATING		PIPE SIZE	BODY HEIGHT				
	MIN	MAX		LOAD RATING	D.I. (-4)		NO HUB (STANDARD)	PUSH ON (P)	THREADED (T)	INSIDE CAULK (X)	PVC/ABS (-30)/(-31)
12" x 12" (305 x 305)	2 1/4" (57)	4 1/8" (105)	51 in ² (32,903 ²)	ANSI/ASME LOAD CLASS "SPECIAL DUTY" (OVER 10,000 LBS.)	2" (51)	6" (152)	6 1/8" (156)	5 7/16" (138)	6 1/4" (159)	7 1/8" (181)	
					3" (76)	6" (152)	6 1/8" (156)	5 7/16" (138)	6 1/4" (159)	7 3/8" (187)	
					4" (102)	6" (152)	6 1/8" (156)	5 7/16" (138)	6 1/4" (159)	7 3/8" (187)	
					5" (127)	6" (152)	—	5 7/16" (138)	6 1/4" (159)	—	
					6" (152)	7 1/4" (184)	7" (178)	7" (178)	6 1/4" (159)	—	

SUFFIX OPTIONAL VARIATIONS

- 4 Ductile iron strainer
- 6 Security screws (T-20 Torx & pin)
- 7 1/2" trap seal primer connection
- 8 Backwater valve (2", 3", 4")
- 11 Acid resistant epoxy coated body
- 12 Galvanized top assembly
- 13 Galvanized body
- 15 2" Extension (-TE)
- 28 Stainless steel body and grate (Type 304)
- 30 PVC socket connection body
- 31 ABS socket connection body
- 40 Underdeck clamp
- 41 Sump receiver

SUFFIX OPTIONAL VARIATIONS

- 80 All aluminum (Medium duty load rated)
- 90 Threaded side outlet (2", 3", 4")
- 90NH No hub side outlet (2", 3", 4")
- BA Buy American Act compliant product
- C Membrane clamp
- HP Heel proof grate (1/4" maximum grate opening size, -3 only)
- (Standard) No hub outlet
- MG MI-GARD Floor Drain Trap Sealer (2", 3" or 4")
- P Push on outlet
- PA Pennsylvania Steel Act compliant product
- T Threaded outlet (2", 3", 4")
- X Inside caulk outlet

CALIFORNIA PROPOSITION 65 WARNING. This product contains chemicals known to the State of California to cause cancer and birth defects or other reproductive harm.

Job Name: _____ Page No: _____

Section No: _____ Contractor: _____

Schedule No: _____ Purchase Order No: _____