

Location: _____



F1170-C-SD

FLOOR DRAIN WITH MULTI INLETS AND INTEGRAL TRAP AND SQUARE SOLID HINGED COVER FOR MEMBRANE FLOOR AREAS

Specification: MIFAB® Series F1170-C-SD lacquered cast iron floor drain with integral trap, 2" (51) cleanout (rodding eye), anchor flange, cast iron membrane clamp ring with primary and secondary weepholes for waterproofing membrane, and adjustable "SD6" square 6" x 6" (152 x 152) with solid hinged cover and secondary grate. (Specify -44, 2" (51) no hub inlets as shown and required. Maximum three @ 90 degrees. Specify location -A, B, or C.)

Function: Used in toilets, kitchens and other membrane finished areas where additional inlets are required to receive drainage. Integral deep seal trap prevents sewer gas from entering area.

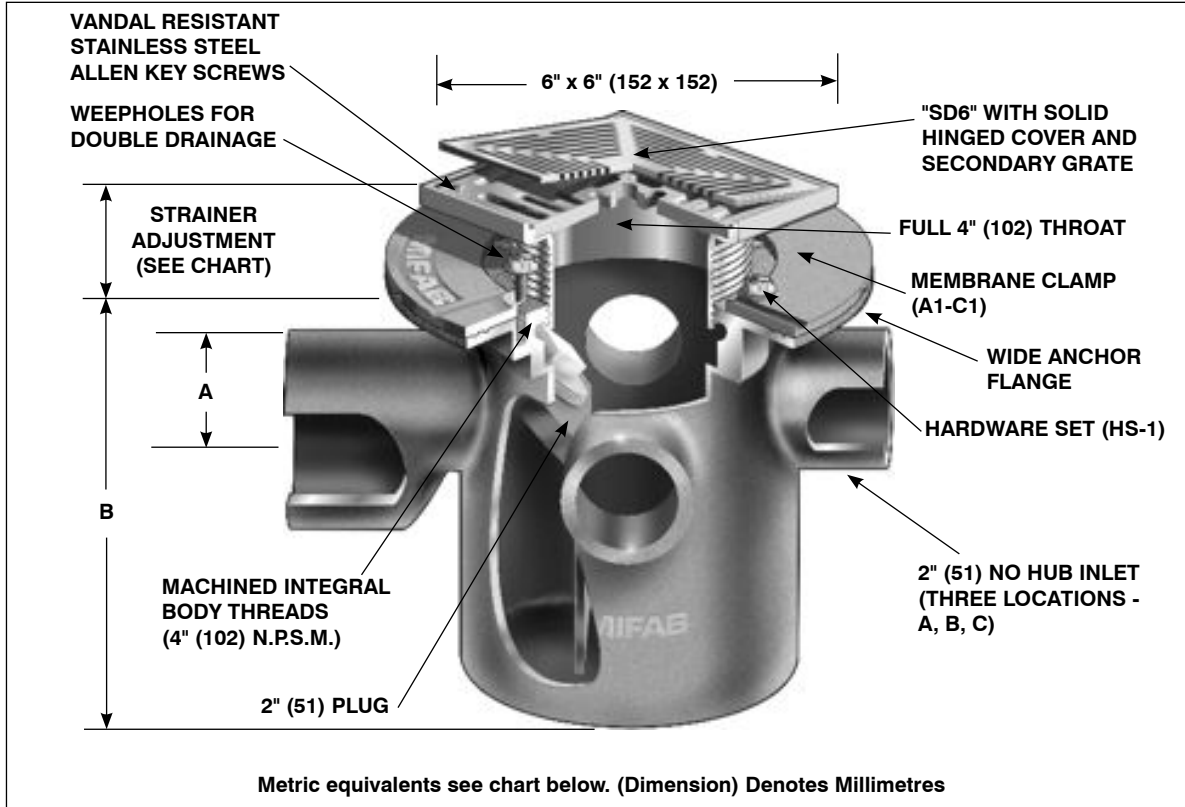

PARTS:



F117(*)
(*) Denotes Outlet Size



(*)-(**)
(*) Denotes Strainer Diameter (5", 6", 7", 8" or 10")
(**) Denotes Strainer Finish (-1, -3 or -4)



A1-C1



HS-1

Metric equivalents see chart below. (Dimension) Denotes Millimetres

STRAINER DIAMETER	STRAINER ADJUSTMENT		ANSI/ASME RATING			PIPE SIZE	BODY HEIGHT	
			FREE AREA	LOAD RATING			A	B
	MIN	MAX		N.B. (-1)	S.S. (-3)			
6" x 6" (152 x 152)	2" (51)	3 1/8" (79)	12 in ² (7700 ²)	UP TO	5000-7499	3" (76)	3 3/4" (95)	7 7/8" (200)
				2,000 LBS.	LBS.	4" (102)	3 3/4" (95)	7 7/8" (200)

F1170-C-SD Series meets ANSI-ASME floor drain standard A112.6.3-2001

SUFFIX OPTIONAL VARIATIONS

- 1 Nickel bronze strainer and cover
- 3 Stainless steel strainer
- 4 Ductile iron grate (5" x 8" only) (standard)
- 5 Sediment bucket
- 6 Security screws (T-20 Torx & pin)
- 7 1/2" trap seal primer connection
- 8 Backwater valve (2", 3", 4")
- 11 Acid resistant epoxy coated body
- 13 Galvanized body
- 15 Extension
- 34 Closure plug

SUFFIX OPTIONAL VARIATIONS

- 44 2" (51) no hub inlet (specify A, B, C locations)
- 49 Chrome Plated Strainer
- 95 Client logo
- BA Buy American Act compliant product
- C2 High rough-in membrane clamp (min. 1 9/16" (40))
- HP Heel proof grate (1/4" maximum grate opening size, -3 only)
- MG MI-GARD Floor Drain Trap Sealer (2", 3" or 4")
- PA Pennsylvania Steel Act compliant product
- Z Extended wide elastomeric flange

Job Name: _____ Page No: _____
 Section No: _____ Contractor: _____
 Schedule No: _____ Purchase Order No: _____