

Location: _____



F1100-90

FLOOR DRAIN WITH SIDE OUTLET FOR NON-MEMBRANE FLOOR AREAS

Specification: MIFAB® Series F1100-90 lacquered cast iron floor drain with anchor flange, weepholes, threaded side outlet, and standard reinforced (specify diameter), (specify strainer finish) strainer. (For membrane floors, use MIFAB F1100-C-90 Series.

Function: Used in showers, kitchens, restrooms and other non-membrane finished areas where shallow side outlet body connection is required. Round adjustable strainer is used for all types of poured finished floors.

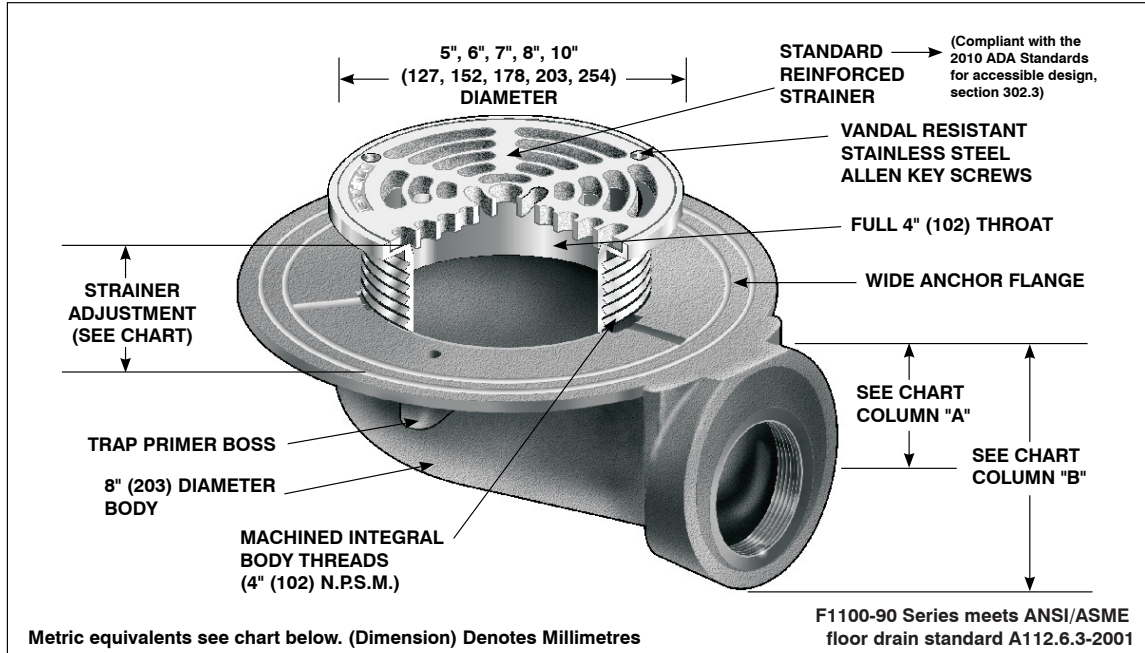

PARTS:



A1-(*)T-90
(*) Denotes Outlet Connection Size (2", 3" or 4")



(*)-(**)
(*) Denotes Strainer Diameter (5", 6", 7", 8" or 10")
(**) Denotes Strainer Finish (-1, -3 or -4)

F1100-90 Series meets ANSI/ASME floor drain standard A112.6.3-2001

STRAINER DIAMETER	STRAINER ADJUSTMENT		FREE AREA	ANSI/ASME RATING			PIPE SIZE	BODY HEIGHT	
	MIN	MAX		LOAD RATING				A	B
				N.B. (-1)	S.S. (-3)	D.I. (-4)			
5" (127)	1/2" (13)	1 1/2" (38)	8 in ² (52002)	Up To 2000 Lbs.	5000 To 7499 Lbs.	Up To 7,499 Lbs	2" (51)	2 15/16" (75)	3 7/8" (98)
6" (152)	11/16" (17)	1 1/2" (38)	9 in ² (58002)	Up To 2000 Lbs.	5000 To 7499 Lbs.	-	3" (76)	3" (76)	4 3/8" (111)
7" (178)	9/16" (14)	1 9/16" (40)	12 in ² (77002)	Up To 2000 Lbs.	5000 To 7499 Lbs.	-	4" (102)	3 1/4" (83)	4 3/8" (111)
8" (203)	11/16" (32)	2 1/4" (57)	18 in ² (116002)	-	5000 To 7499 Lbs.	Up To 10,000 Lbs			
10" (254)	1 1/16" (17)	2 1/4" (57)	26 in ² (171702)	-	5000 To 7499 Lbs.	-			

SUFFIX	OPTIONAL VARIATIONS
-1	Nickel bronze strainer (standard)
-3	Stainless steel strainer
-4	Ductile iron strainer (5", 8" only)
-5	Sediment bucket
-6	Security screws (T-20 Torx & pin)
-7	1/2" trap seal primer connection
-8	Backwater valve (2", 3", 4")
-11	Acid resistant epoxy coated body
-13	Galvanized body
-15	Extension
-21	Secondary flat stainless steel strainer (2", 3", 4")
-34	Closure plug
-40	Underdeck clamp
-41	Sump receiver
-49	Chrome plated strainer

-50	Lacquered cast iron funnel
-90	Threaded side outlet (2", 3", 4") (cast iron only)
-95	Client logo
-BA	Buy American Act compliant product
-C	Membrane clamp for low rough-in (min. 1/2" (13))
-C2	High rough-in membrane clamp (min. 1 9/16" (40))
-F4	4" Round funnel
-F6	6" Round funnel
-G	Oval 4" x 9" funnel
-J	6" x 3" x 1" funnel
-MG	MI-GARD Floor Drain Trap Sealer (2", 3" or 4")
-NH	No hub side outlet
P	Push on outlet
-PA	Pennsylvania Steel Act compliant product
-Z	Extended wide elastomeric flange

CALIFORNIA PROPOSITION 65 WARNING. This product contains chemicals known to the State of California to cause cancer and birth defects or other reproductive harm.

Job Name: _____ Page No: _____
 Section No: _____ Contractor: _____
 Schedule No: _____ Purchase Order No: _____