

Location: _____



C1200-C

ISOLATION (FLOATING) FLOOR CLEANOUT WITH ADJUSTABLE COVER AND PLUG

Specification: MIFAB C1200-C Series (specify top assembly design) adjustable floor cleanout with lacquered cast iron upper body and lower bodies with anchor flanges, secondary "O" ring Test Seal, cast iron membrane clamp rings for waterproofing membrane, neoprene expansion compensator, 4" cleanout opening and scoriated combined cover and plug top assembly (specify material type) with stainless steel vandal proof allen key screws and primary gasket seal.

Function: Used in computer rooms and other areas that have cables and wires underneath a floating floor assembly to provide emergency access to the plumbing lines for removal of blockages. Neoprene expansion compensator provides flexibility with floating floor system. Membrane clamp is bolted onto the anchor flange, securing the waterproof membrane in place. Seepage control is not available since cleanouts must be gas tight. Replacement of the surface level cover/plug with the neoprene gasket glued to the underside provides visual evidence that the cleanout has been properly resealed to prevent harmful sewer gases from entering the building.

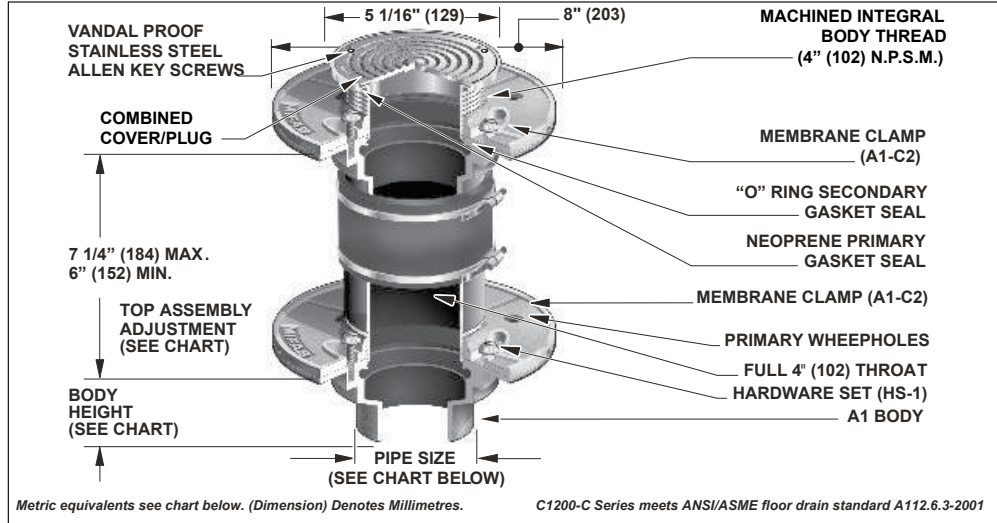

OPTIONAL TOP ASSEMBLIES:

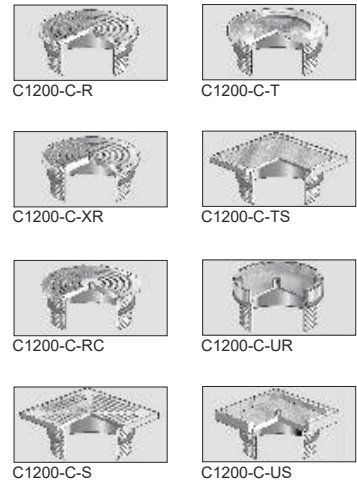

TOP ASSEMBLY DIAMETER	TOP ASSEMBLY ADJUSTMENT		ANSI/ASME RATING			PIPE SIZE	BODY HEIGHT				
	MIN	MAX	LOAD RATING				NO HUB (STANDARD)	PUSH ON (P)	THREADED (T)	INSIDE CAULK (X)	PVC/ABS (-30)/(-31)
			N.B. (-1) Lbs.	S.S. (-3) Lbs.	D.I. (-4) Lbs.						
5" (127)	1/2" (13)	1 1/4" (32)	Up to 4,999	5,000 to 7,499	Special Duty Over 10,000	2" (51)	3" (76)	3 3/8" (86)	2 1/4" (57)	3 3/4" (95)	2 15/16" (75)
						3" (76)	3" (76)	3 3/8" (86)	2 5/8" (67)	3 3/4" (95)	3 3/4" (95)
						4" (102)	3" (76)	3 3/8" (86)	2 5/8" (67)	3 3/4" (95)	3 3/4" (95)
						5" (127)	3" (76)	--	2 5/8" (67)	3 3/4" (95)	--
						6" (152)	3 1/4" (83)	6 1/2" (165)	--	--	--

Suffix	Description
-1	Nickel bronze top assembly
-3	Heavy duty stainless steel top assembly
-4	Extra heavy duty ductile iron top assembly for unfinished areas
-6	Security screws (TR25 Torx & pin)
-6S	6" x 6" square top assembly (-1 or -3 only)
-11	Acid resistant epoxy coated body
-13	Galvanized body
-15	Extension
-28	Stainless steel body (Type 304)
-30	PVC socket connection body
-31	ABS socket connection body
-34	Secondary closure plug
-90	Threaded side outlet (2", 3", 4") (cast iron only)
-90NH	No hub side outlet (2", 3", 4") cast iron only
-95	Special marking etched into top(SAN for sanitary or GW for Grease Waste)
-BA	Buy American Act compliant product

-C	Membrane clamp
(Standard)	No hub outlet
P	Push on outlet
-PA	Pennsylvania Steel Act compliant product
-R	Round top assembly
-RC	Stainless steel carpet maker
-RCF	Stainless steel carpet flange cover (-1 or -3 only)
-S	Square top assembly (-1 or -3 only) (5" x 5")
-T	Round top assembly recessed 1/8" for tile
T	Threaded outlet (2", 3", 4")
-TS	Square top assembly recessed 1/8" for tile (-1 or -3 only)
-UR	Round top assembly recessed 1 1/4" for terrazo (-1 or -3 only)
-US	Square top assembly recessed 1 1/4" for terrazo (-1 or -3 only)
X	Inside caulk outlet
-XR	Heavy duty top round assembly
-XS	Heavy duty square top assembly
-Z	Extended wide elastomeric flange

CALIFORNIA PROPOSITION 65 WARNING. This product contains chemicals known to the State of California to cause cancer and birth defects or other reproductive harm.

Job Name: _____ Page No: _____
 Section No: _____ Contractor: _____
 Schedule No: _____ Purchase Order No: _____