

INSTALL GUIDE

BIG-750

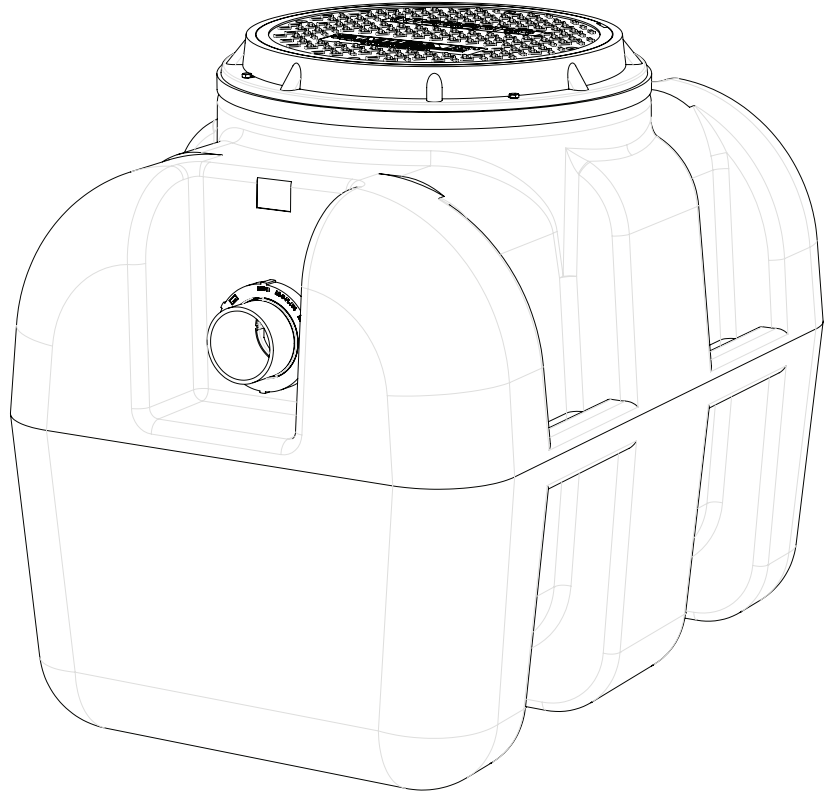

CONTENTS

SPECIAL PRECAUTIONS

GENERAL INSTALL INSTRUCTIONS

BELOW GRADE INSTALL INSTRUCTIONS

EXTENSION COLLAR INSTALL INSTRUCTIONS

PARALLEL OR MULTIPLE INSTALL INSTRUCTIONS

APPLICATION SPECIFIC DETAILS

SPECIAL PRECAUTIONS

1. HIGH TEMPERATURE KITCHEN WATER

If there is water entering the interceptor at over 150°F, a drain water tempering valve and approved backflow prevention assembly must be installed. Generally, state and local plumbing codes prohibit water above 150°F from being discharged into the sewer.

2. HYDROSTATIC SLABS (OR PRESSURE SLABS)

Interceptor must be enclosed in a water concrete vault when installed under a hydrostatic slab (slab designed to withstand upward lift- typically caused by hydrostatic pressure).

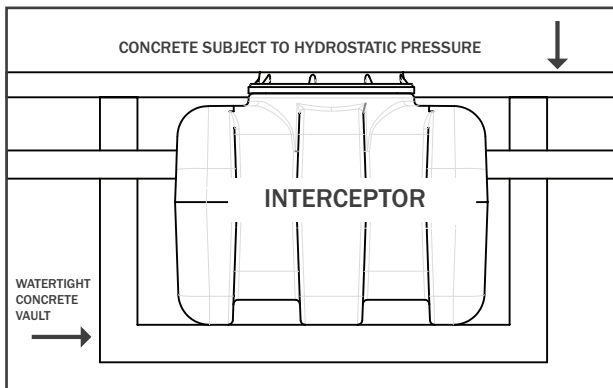

FIG. 2

3. MAXIMUM WATER LEVEL

The water level will never go beyond the level height of Inlet / Outlet connection

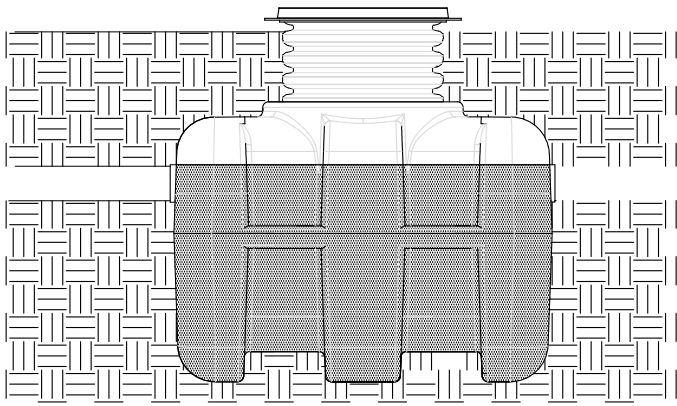

FIG. 3

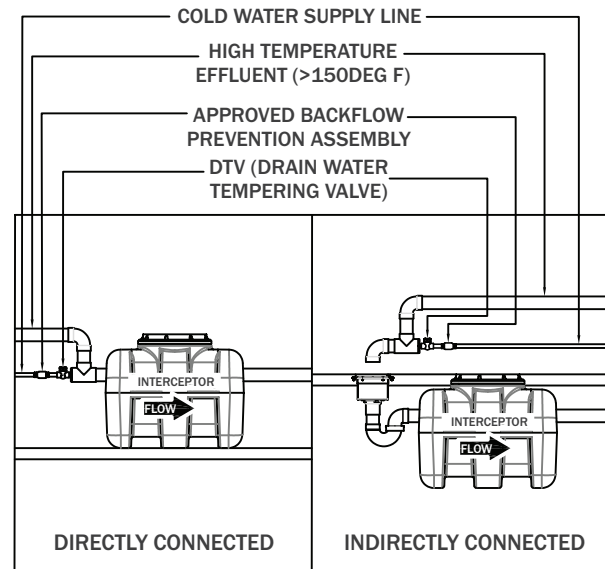

FIG. 1

4. HIGH WATER TABLE INSTALLATIONS

Interceptor and riser cannot withstand excessive water table height - see max water table height in figure 3. If possible, interceptor and riser should be installed in a water-tight concrete vault or backfill with concrete or flowable fill (pour wet concrete and flowable backfill in stages to avoid crushing the interceptor). BIG MAX models buried in high water table are required to be installed with an anchor kit. High Risk Areas: Floodplains, tidal surge and high storm-water areas.

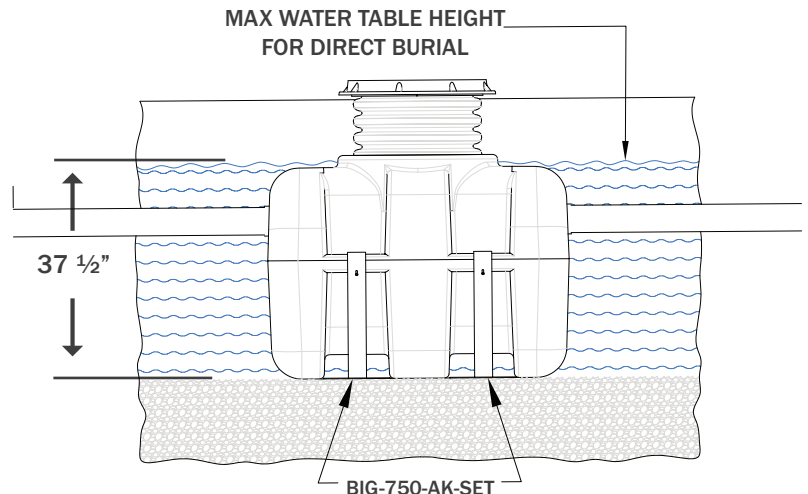

FIG. 4

SPECIAL PRECAUTIONS

5. ABOVE GRADE INSTALLATION SUPPORT - ANCHOR KITS

Anchor kit is recommended for installation in high water table conditions to prevent float out. Necessity to be determined by Project Engineer. Hold down force achieved by backfill weight acting on Anchor plates. Place Anchor hook over handle on interceptor. Bolt hardware through hole of anchor hook, to ensure hook does not become removed. Anchor plate may be bolted to concrete slab using provided holes.

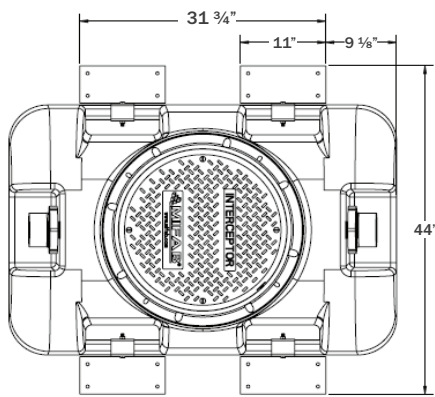
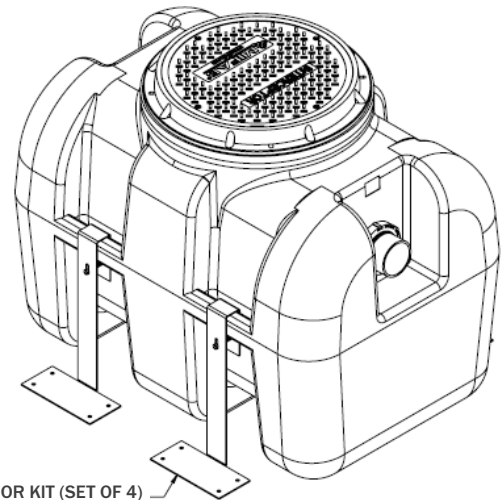

FIG. 5



ANCHOR KIT (SET OF 4)
TO BE PLACED ON EACH HANDLE

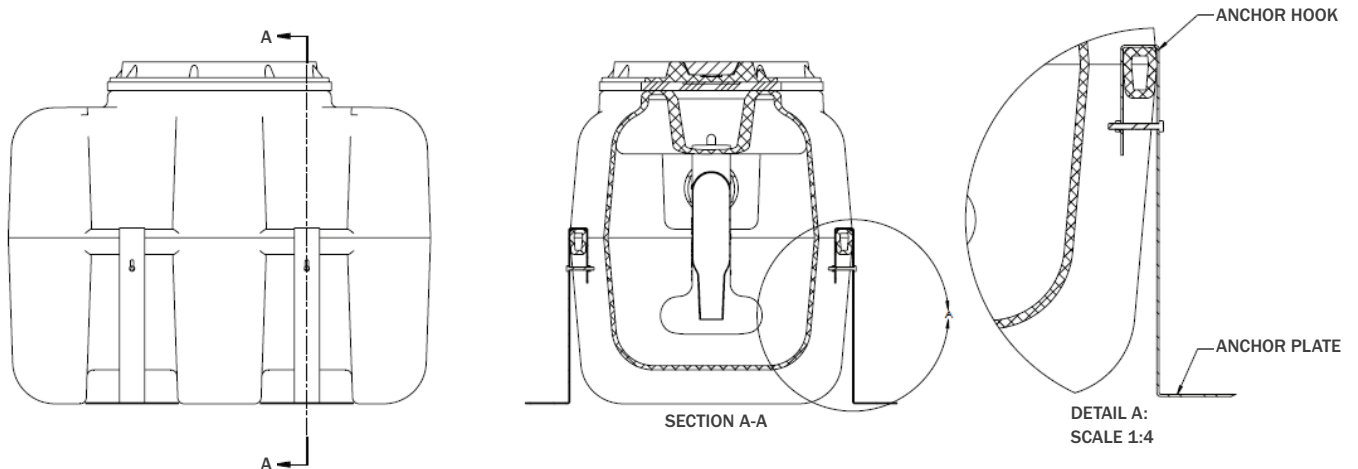

FIG. 6

SPECIAL PRECAUTIONS

6. FULLY SUPPORT BASE OF UNIT

Interceptor must be installed on solid level surface with contact made on the entire footprint of the unit base. For suspended installations, a trapeze must be used to support the wet weight of the unit. The whole unit must be supported at all times - do not suspend unit using metal U-channel to create a trapeze.

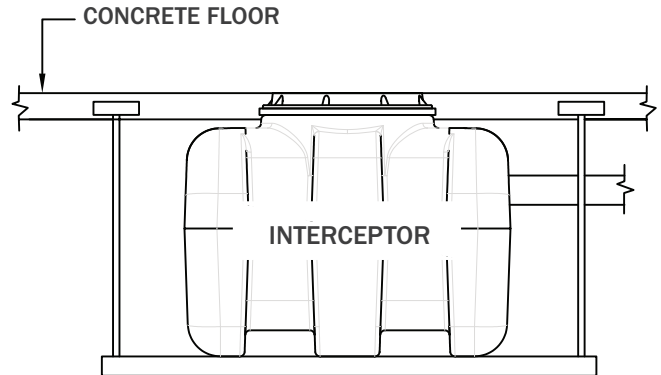

FIG. 7

7. SUPPORT INLET AND OUTLET PIPING

The inlet and outlet piping connections require no hub pipe couplings. (See MIFAB®'s Quick Hub Series of no hub couplings). Keep outlet piping as straight as possible. MIFAB® recommends installation of 4" (102 mm) cleanouts on both the Inlet and Outlet of 4" BIG MAX® Interceptors and Solids Interceptors in accordance with all applicable laws, regulations and codes. Use only "sweep" connections. Do not reduce the pipe sizing on the outlet piping. Do not install a "P" trap on the outlet connection of system. (Note: The system already has an internal gas trap).

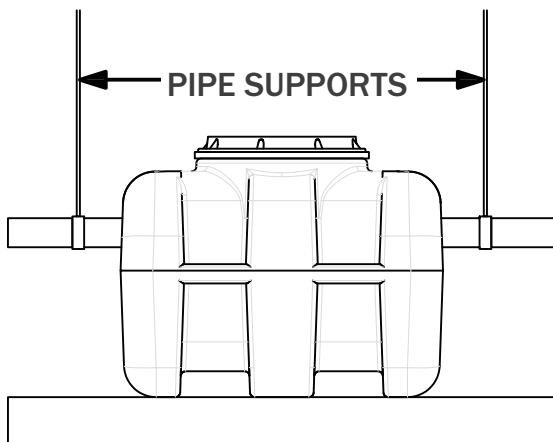

FIG. 8

**DO NOT COMPACT BACKFILL MECHANICALLY.
COMPACT BY HAND ONLY**

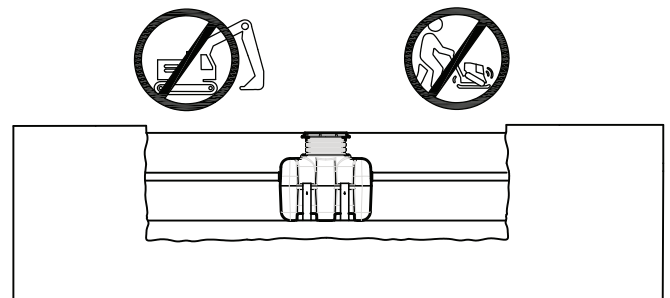

FIG. 9

INSTALLATIONS

GENERAL INSTALLATION

1. All BIG MAX and LIL MAX interceptors can be installed above grade. The HDPE ribbed construction allows these interceptors to be placed on an engineered approved, load compliant and level surface. Under normal use, BIG MAX and LIL MAX interceptors will require no additional support to maintain full functionality. Seismic ratings and needs should be determined by a design engineer and based on established codes. The Interceptor should be placed in a visible and easily accessible area for maintenance, cleaning, and inspection. Allowing space for the service provider to properly clean the vessel is a key consideration to efficient functionality.

2. MIFAB Interceptors should be set in place by the installer. The installer should ensure the pad/site is level and load rate compliant. The total weight of a BIG-750 has a designed storage capacity is 1,950 lbs. The unit should then be plumbed as instructed below in accordance with all required codes.

3. When installing a MIFAB Interceptor, proper venting is strongly recommended. Venting can be installed on the outlet of the unit which is preferred, or as close as possible to the outlet connection. MIFAB recommends a vent at least 50% the diameter of the system's outlet connection. As an example the BIG-750 will require a 2" vent. A BIG or LIL interceptor can be connected to the facility supplied venting or as directed by the designing engineer. **ALWAYS** consider and follow all local and industry code requirements.

4. Connection to the plumbing system is achieved by the use of no hub couplings. MIFAB recommends the use of Quick Hub no hub couplings. This will provide protection for the pipe at the connection points and ensure a strong connection between the Big and Lil Max Unit and the plumbing system. No hub couplings should be installed and torqued to the supplying manufacturers recommendations. As an example the BIG-750 will require 4" couplings.

5. Each BIG MAX and LIL MAX unit is supplied with a factory sized internal flow control for each size unit available. An optional, external vented flow control fitting is available when the -PDI suffix is selected.

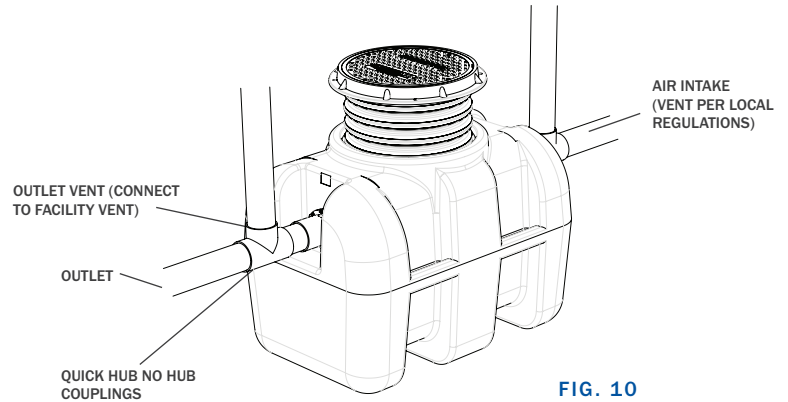

FIG. 10

6. Pipe supports should be located every 16" on all vertical and horizontal piping. Allow for expansion as per local and national codes.

7. When combining more than one grease or solids interceptor in series or parallel always provide a 1" fall or change in grade between units.

INSTALLATIONS

BELOW GRADE/BACKFILL INSTALL:

1. Install the interceptor(s) as close as practical to the fixtures being served.
2. The excavation must be a minimum of 12" greater on all sides of the tank.
3. The depth of the excavation must be greater than 6" on the bottom of the interceptor.
4. Backfill while filling the interceptor with water at an equal rate until you reach the inlet/outlet. (Do not pack the backfill)
5. Fully install the double wall corrugated pipe and lid prior to backfilling.
6. Concrete or finishing material requirements is to be determined by the specifying engineer.
7. Encase the interceptor in well-packed ¾" rock, or sand. Do not compact backfill around interceptor.
8. To prevent float out; the Anchor kit is recommended for installations in high water table conditions. This is to be determined by the specifying engineer.

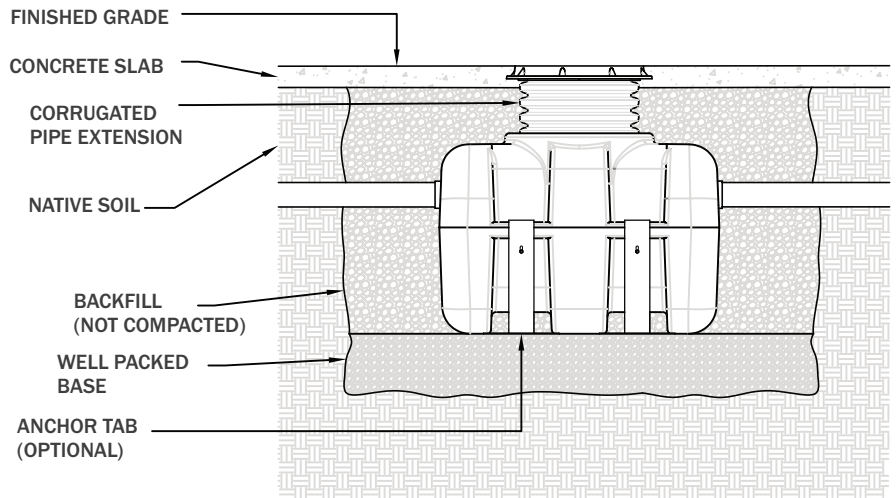

FIG. 11

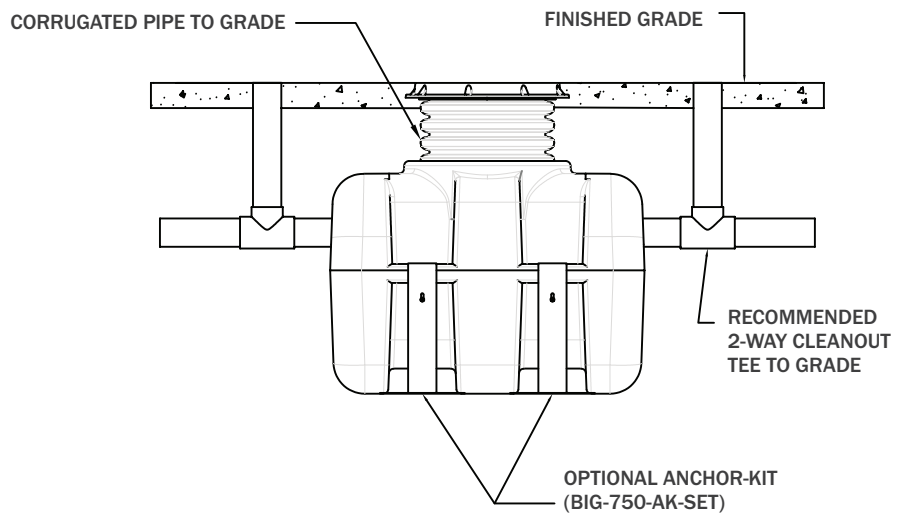

FIG. 12

FINISHED CONCRETE SLAB

Slab must extend 18" minimum outside the footprint of the unit. **Pedestrian traffic areas:** 4" Thick reinforced concrete slab required. **Vehicular traffic areas:** Minimum 8" thick concrete slab with rebar is required.

Thickness of concrete around cover to be determined by specifying engineer. If traffic loading is required, the concrete slab dimensions shown are for guiding purposes only. Concrete to be 28 day compressive strength to 4,000 PSI. Use #4 rebar (1/2") grade 60 steel per ASTM A615: connected with tire wire. Rebar to be 2-1/2" from edge of concrete and spaced in a 12" grid with 4" spacing around access openings.

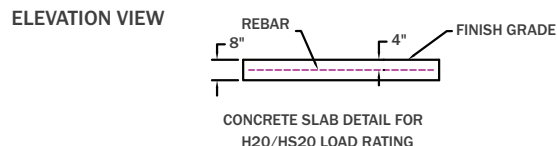
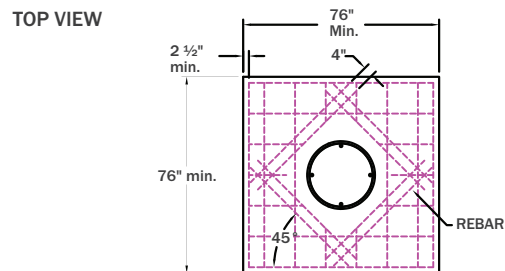

FIG. 13

CONCRETE SLAB DETAIL

INSTALLATIONS

EXTENSION COLLAR INSTALLATION

1. Set the BIG MAX unit height to grade by installing the 18" diameter corrugated pipe onto the top opening(s) of the body, then insert the lid on top to measure and adjust the finished height from the top to grade. If less extension is needed, measure the required dimension and mark the extension. Then, cut to fit with a saw. The extension system is ADS pipe and is designed to be field cut as needed. If a longer extension is required to meet grade, new ADS pipe can be purchased and cut to length in order to equal grade. (ADS pipe part #18N12)

2. Install the Pipe Gasket between the bottom ribs. Then firmly press the 18" diameter pipe into the top opening(s) of the interceptor. It will bottom out at the pipe stop. The Gasket is designed to fit tightly around the extension collar. Prying the gasket into place with a pry tool can save time and make this process easier. Watch the installation video at www.bit.ly/ADS-gasket

3. Insert the extension collar and pipe gasket onto the opening of the BIG MAX. Press firmly until the extension is seated inside the provided recessed channel. The BIG MAX is designed to fit tightly, and installation can be made easier by wetting the receiving area with mild soapy water. This will reduce the friction and allow the extension to press more easily into place.

4. Remove the cover from the lid assembly to see the predrilled screw holes. Affix the lid gasket with the self adhesive onto the underside of the collar. Place lid assembly onto the top of the corrugated pipe. Connect the lid assembly collar to the pipe with the 6 self tapping screws into the countersunk holes. Replace lid back onto the lid assembly collar.

5. When installing the collar on concrete roads, an 8 inch-width concrete ring beam with a 16" width guard circle around it should be poured between the collar and brick setting to make the surrounding compaction level and unmovable.

6. When installing the collar on a bituminous road, the collar must be installed after the road is paved. Roller compaction by construction equipment around the collar must be avoided. A hole that is slightly larger than the collar should be inserted before pouring the pavement. The reserved hole can help ensure the installation quality and prolong the usefulness of the installation.

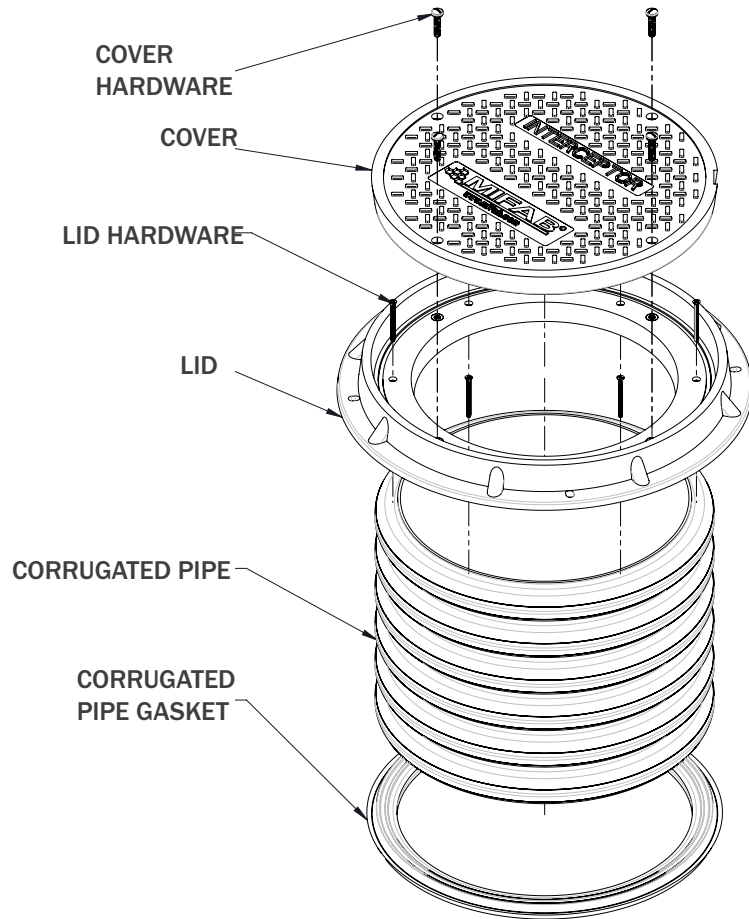

FIG. 14

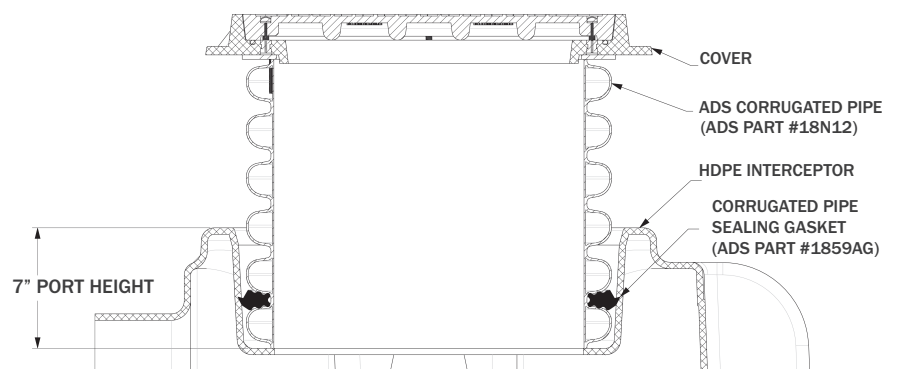

FIG. 15

INSTALLATIONS

PARALLEL INSTALLATION OF MULTIPLE GREASE INTERCEPTORS

When installing multiple BIG MAX units in series or parallel the elevation change from the preceding unit's center line to the next unit's center line should be 1" inch. This is to allow gravity to supply the required rate of fall and control the rate of flow to allow the needed separation time.

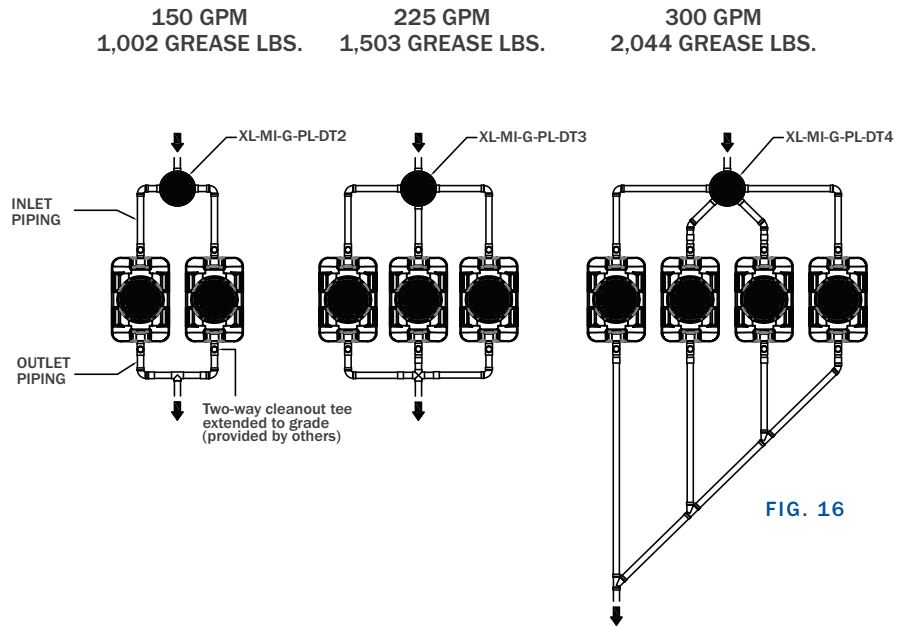
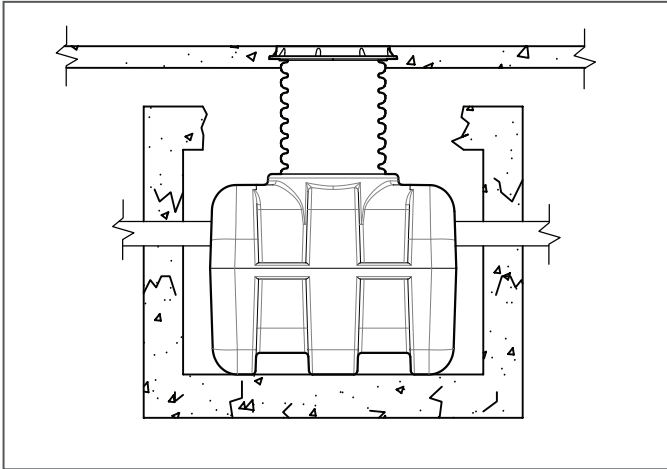
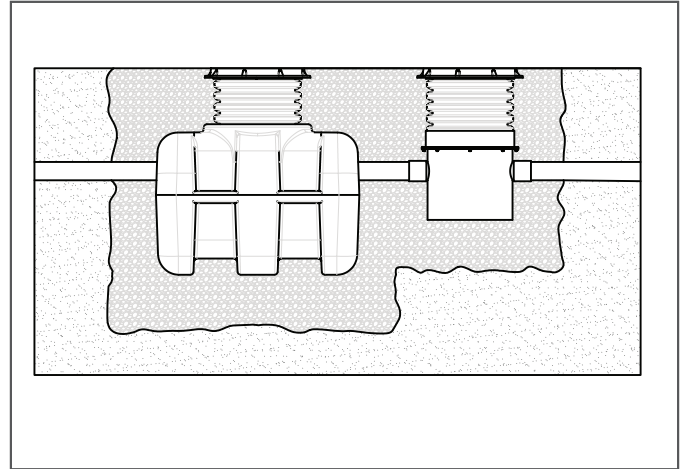

FIG. 16

APPLICATION SPECIFIC DETAILS



INSIDE CORRODED CONCRETE UNIT



BELOW GROUND INSTALLATION

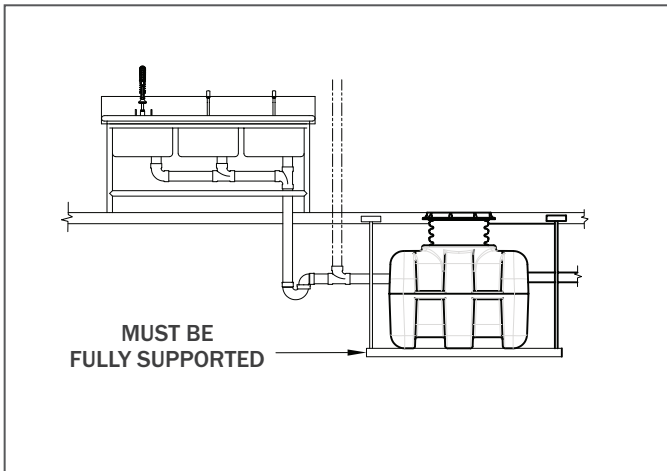

RECESSED AND SUSPENDED

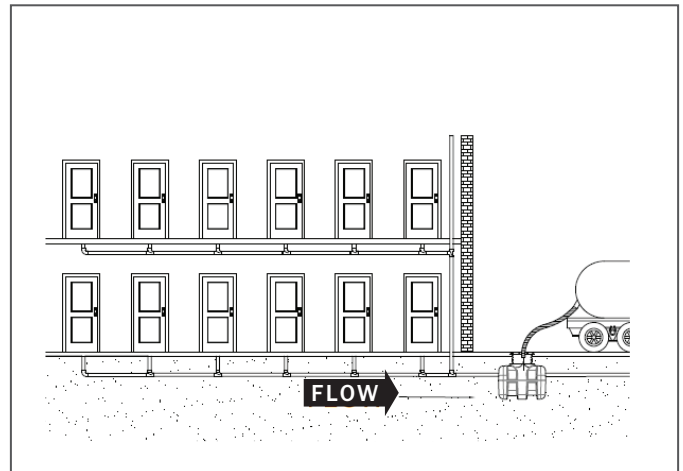

SERVING AN APARTMENT COMPLEX

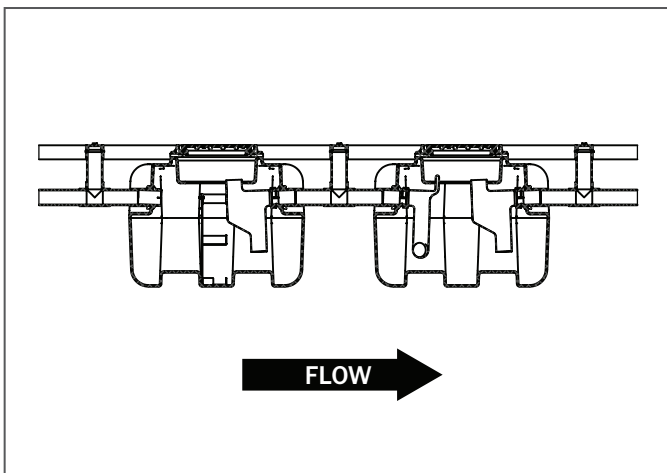

BIG-300-S SOLIDS INTERCEPTOR IN FRONT OF BIG-750 GREASE INTERCEPTOR

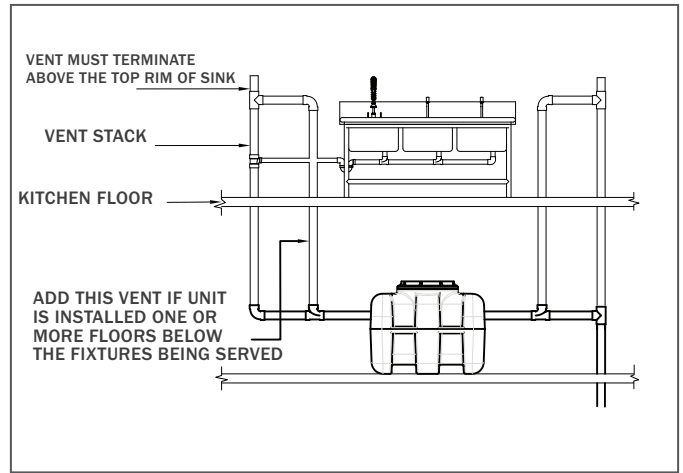

ADDITIONAL VENTING FOR FLOOR-BELOW INSTALL