

Location: _____



A5-MD

CAST IRON DOME FOR LARGE ROOF DRAINS

Specification: MIFAB® A5-MD lacquered cast iron, self locking, large roof dome strainer with a free area of 125 square inches.

Function: Used with MIFAB's R1220 Series large roof drains. Large free area dome provides for drainage of rain water and prevents debris from entering the drain line.

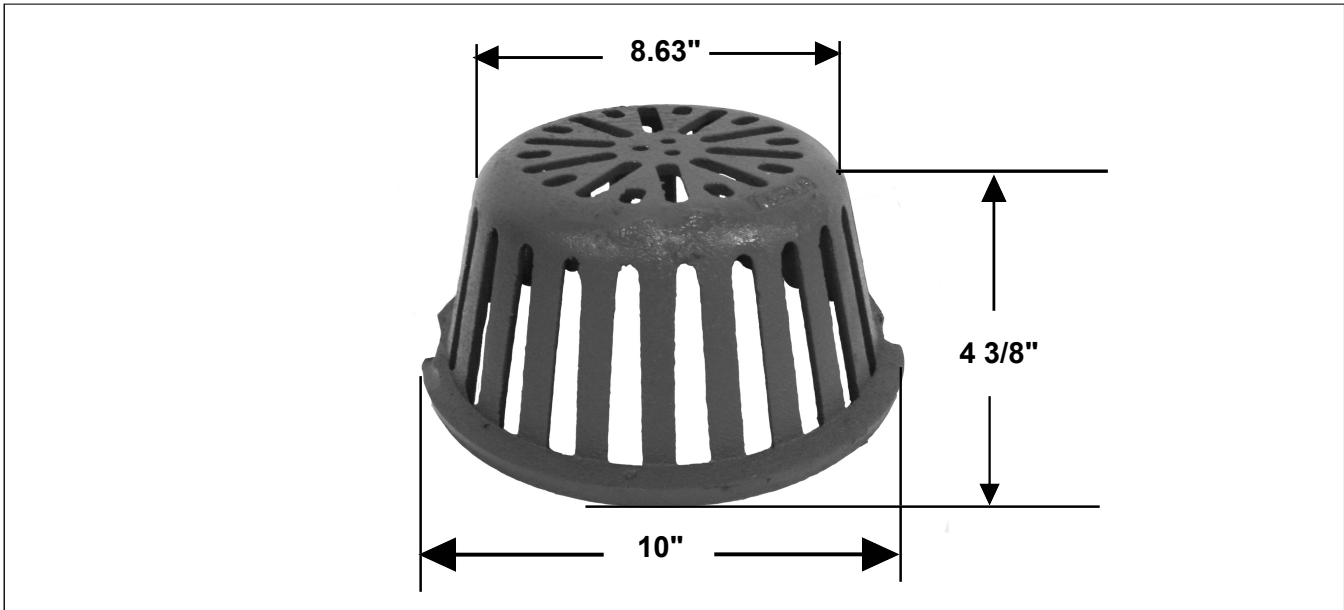

PART NO.	DESCRIPTION
A5-MD	Cast iron dome (R1220)

SUFFIX	OPTIONAL VARIATIONS
-11	Acid resistant powder epoxy coating
-13	Galvanized coating
-83	Stainless steel mesh screen over metal dome

CALIFORNIA PROPOSITION 65 WARNING. This product contains chemicals known to the State of California to cause cancer and birth defects or other reproductive harm.

Job Name: _____ Page No: _____
Section No: _____ Contractor: _____
Schedule No: _____ Purchase Order No: _____