



# T1150-F

## 12" WIDE TRENCH DRAIN GRATE AND FRAME

Internet address: [www.mifab.com](http://www.mifab.com)

Toll Free: 1-800-465-2736

Canada Toll Free: 1-800-387-3880

**SPECIFICATION:** MIFAB Series T1150-F \_\_\_\_\_ 12" (300) wide x (specify length) long ductile iron trench drain grate with angle iron frame. Grates to have maximum 3/8" (9) openings. Supply in sections as indicated on drawing.

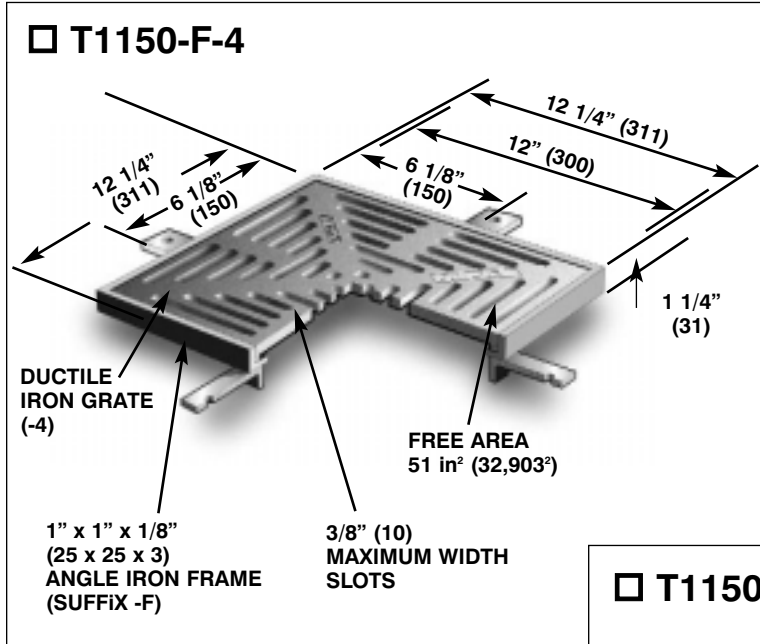

Metric equivalents see chart below.  
(Dimension) Denotes Millimetres

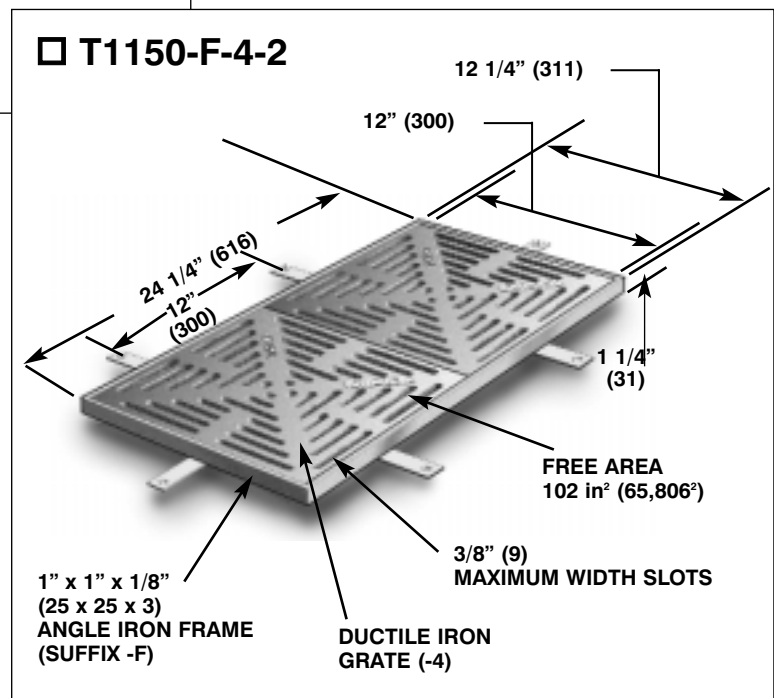

MODEL NO.	SIZE	GRATE MATERIAL	FRAME MATERIAL
T1150	12" x 12" (300 x 300)	Ductile iron	Grate only
T1150-F-4	12" x 12" (300 x 300)	Ductile iron	Steel
T1150-F-4-2	12" x 24" (300 x 610)	Ductile iron	Steel
T1150-F-4-3	12" x 12" (300 x 300)	Ductile iron, Stainless steel veneer	Stainless steel
T1150-F-4-3-2	12" x 24" (300 x 610)	Ductile iron, Stainless steel veneer	Stainless steel

**OPTIONAL VARIATIONS:**

- Nickel bronze (vener)
- Stainless steel (vener)**
- 3M epoxy finish
- Vandal proof

- suffix -1
- suffix -3**
- suffix -3M
- suffix -6

- Acid resistant epoxy coating
- Galvanized grate
- All galvanized
- Client logo

- suffix -11
- suffix -12
- suffix -13
- suffix -95