

**Specification:** MIFAB® Series MI-GRILL nickel bronze fresh air inlet with crowned and perforated round design, assembled with adjustable four point contact locking mechanism and vandal proof screw.

**Function:** Used as a protective cover for the fresh air inlet piping at the exterior walls of buildings to permit fresh air to enter the piping system. It is typical that the diameter of the fresh air inlet must be double the pipe diameter that it is servicing.

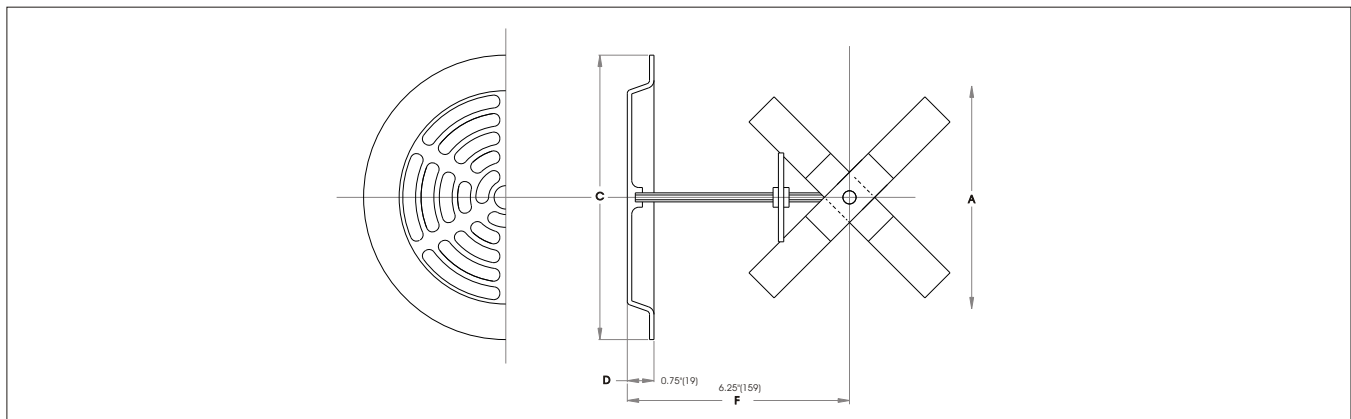
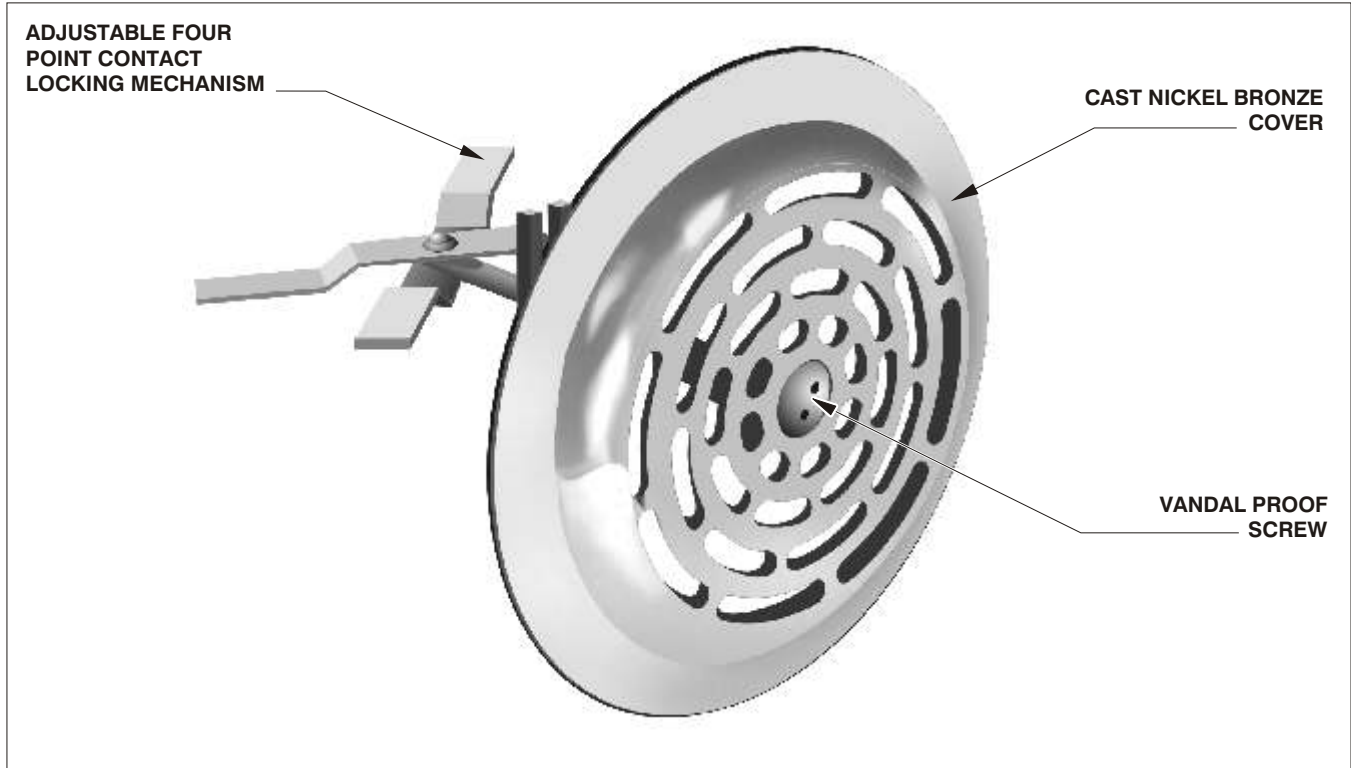

MODEL NUMBER	"A" PIPE SIZE	"C"	"D"	"F"	FREE AREA (SQUARE INCHES)
MI-GRILL-4	3", 4" (76, 102)	8" (203)	3/4" (19)	6 1/4" (159)	9 (229)
MI-GRILL-6	5", 6" (127, 152)	12" (305)	3/4" (19)	6 1/4" (159)	28 (711)
MI-GRILL-8	8" (203)	15" (381)	3/4" (19)	6 1/4" (159)	50 (1270)

**OPTIONAL VARIATIONS:**      **SUFFIX**  
 Chrome plated                      -49

Job Name: _____	Page No: _____
Section No: _____	Contractor: _____
Schedule No: _____	Purchase Order No: _____