



MI-950-F

FUNNEL DRAIN WITH DEEP SEAL TRAP

Specification: MIFAB® Series MI-950-F lacquered cast iron deep seal trap with funnel drain, with 1/2" trap seal primer tapping and cast iron plug, 3/4" low flushing tapping and bronze plug and 1 1/4" bottom bronze cleanout plug.

Function: Used with indirect waste lines that are above the floor and require receptors to receive drip, condensate or waste water in industrial laboratories and hospitals. The deep seal trap prevents sewer gases from entering the room.

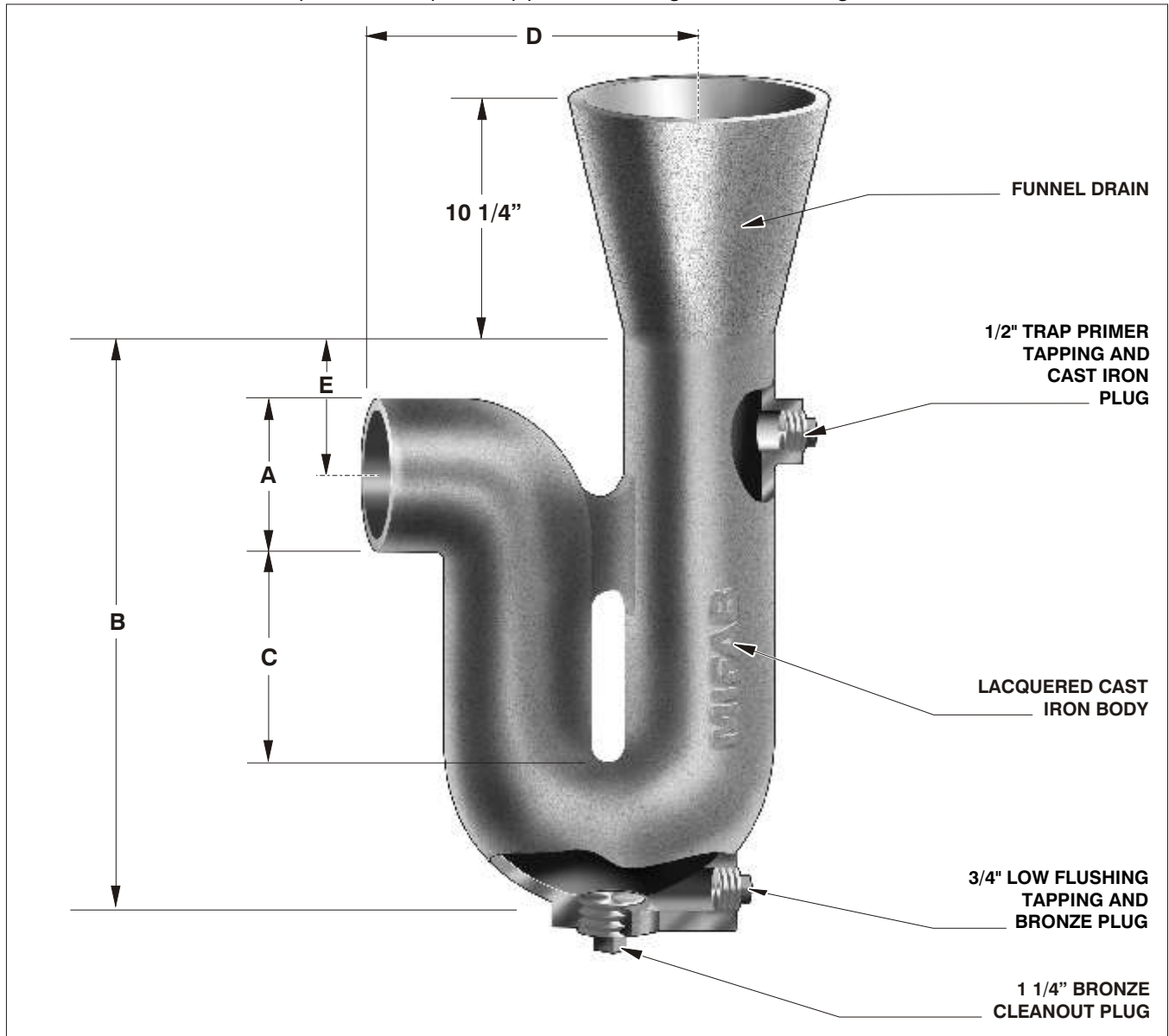

MODEL NUMBER	"A" PIPE SIZE	"B" BODY HEIGHT	"C" TRAP DEPTH	"D" CENTER TO OUTLET	"E" INVERT
MI-952-F	2" (51)	10 1/2" (267)	3 1/2" (89)	6 1/2" (165)	3" (76)
MI-953-F	3" (76)	13 1/2" (343)	4 1/2" (114)	8" (203)	3 1/2" (89)
MI-954-F	4" (102)	15 1/2" (394)	4 1/2" (114)	10 1/2" (267)	4 1/4" (108)

- OPTIONAL VARIATIONS:**
- | | | | | | |
|-------------------------------------------------------|-----------------------|-------------------------------------------------------|----------------------|--------------------------------------------------|----------------------|
| <input type="checkbox"/> 6" Dia. Nickel bronze funnel | SUFFIX
-6-1 | <input type="checkbox"/> Acid resistant epoxy coating | SUFFIX
-11 | <input type="checkbox"/> Secondary dome strainer | SUFFIX
-20 |
| <input type="checkbox"/> 6" Dia. Cast iron funnel | -6-50 | <input type="checkbox"/> All galvanized | -13 | <input type="checkbox"/> Chrome plated | -49 |

Job Name: _____	Page No: _____
Section No: _____	Contractor: _____
Schedule No: _____	Purchase Order No: _____

MIFAB reserves the right to make changes in material and design without formal notice and obligation.