

Specification: MIFAB® Series MC-15D double, vertical, fixed water closet carrier with offset lacquered cast iron fitting, 4" (102) no hub waste, 2" (51) no hub vent connection, lacquered cast iron gasketed adjustable faceplates, universal floor mounted cast iron foot supports, adjustable 8" tapered thread ABS nipples with integral test caps, neoprene bowl gaskets, hardware, threaded rod protectors and polished chrome plated finishing cap nuts.

Function: Used with back to back water closets that are offset from a common stack by 4" in multi-floor installations where minimum pipe space is required. Typical for off the floor plumbing fixtures that are wall mounted and have no contact with the finished floor. The closet carrier is completely concealed within the wall and supports the load of the fixture through a faceplate and foot support system that is anchored to the floor. Sanitation underneath the fixture is more efficiently and economically maintained when installed off of the floor compared to floor mounted.

Note: 9 1/4" (235) minimum space required between front of foot supports.

Note: Foot supports and faceplate are assembled at the factory before shipment in the typical siphon jet water closet configuration and are reversible for the blowout water closet design.

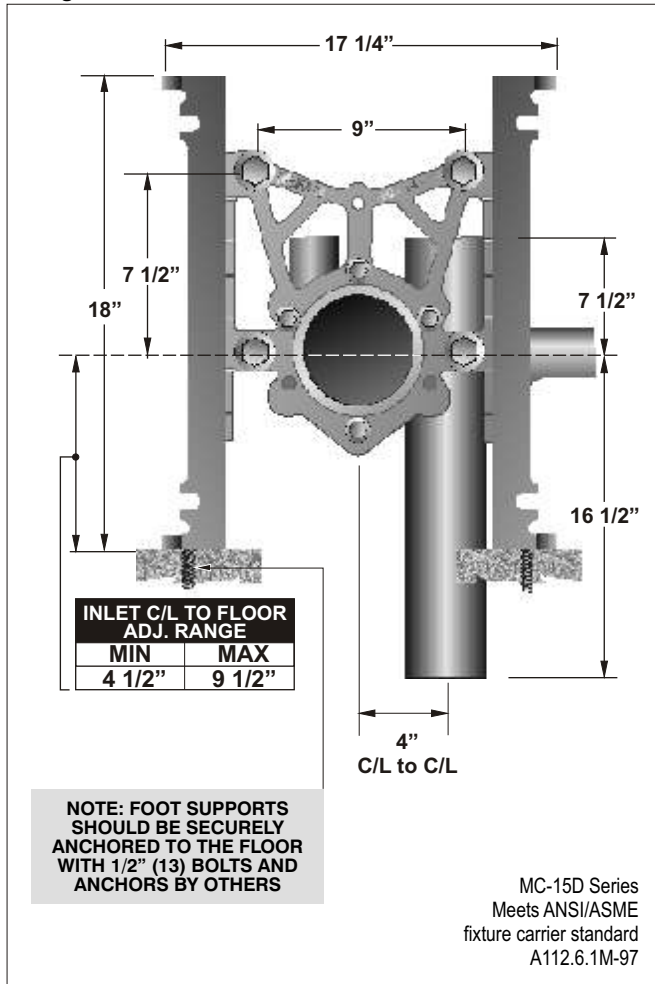

Note: 8" tapered thread ABS nipple shipped standard with MC-15D Series carriers. The universal faceplate assembly accepts all nipple variations, rolling thread (-OR), cast iron (-CI) and tapered thread ABS with adjustable horn (-AH).

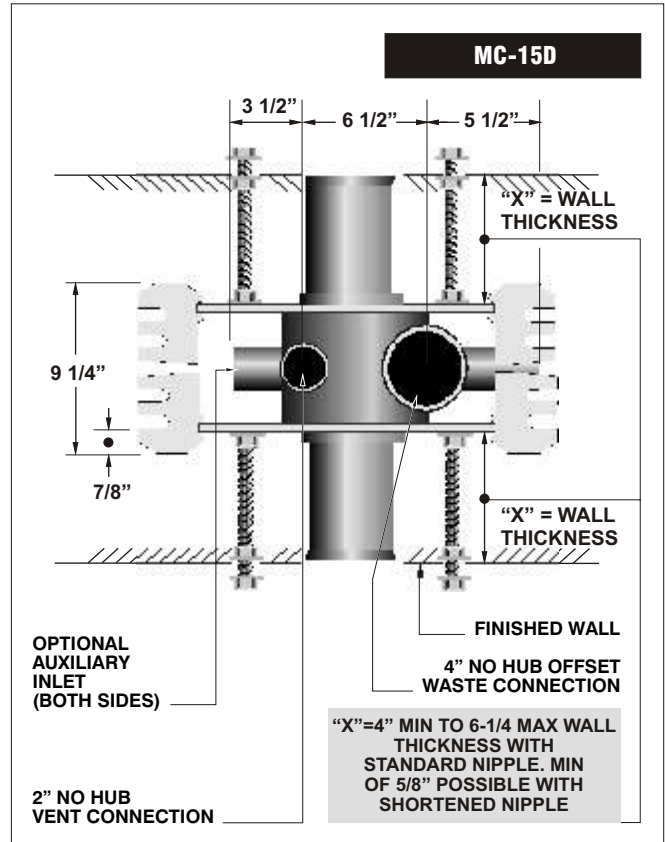

OPTIONAL VARIATIONS:

- 8" ABS nipple with adjustable horn
- 12" ABS nipple with adjustable horn
- 4" rolling thread cast iron nipple
- 6" rolling thread cast iron nipple
- 8" rolling thread cast iron nipple
- 12" rolling thread cast iron nipple
- 24" rolling thread cast iron nipple
- Extra heavy duty 500 lb. load rated carrier
- Hub and spigot connection
- 8" rolling thread ABS nipple
- 12" rolling thread ABS nipple

SUFFIX

- AH8
- AH12
- CI-4
- CI-6
- CI-8
- CI-12
- CI-24
- HD
- HS
- OR8
- OR12

- Finishing / Tiling frame
- Auxiliary support, recommended with nipple lengths over 12"
- 12" tapered thread ABS nipple
- Test plug for custom and cast iron nipples
- Vandal proof finish trim
- Galvanized cast iron
- Nipple wrench
- Flush valve support
- 2" Auxiliary inlet, right side
- 2" Auxiliary inlet, left side
- Two 2" Auxiliary inlets

SUFFIX

- 1
- 10
- 12
- 13
- 14
- 17
- 19
- 20
- 25
- 26
- 31

Job Name: _____	Page No: _____
Section No: _____	Contractor: _____
Schedule No: _____	Purchase Order No: _____