

Specification: MIFAB® Series MC-15 single, vertical, fixed, water closet carrier with offset lacquered cast iron fitting, 4" (102) no hub waste, 2" (51) no hub vent connection, lacquered cast iron faceplate, universal floor mounted cast iron foot supports, adjustable 8" tapered thread ABS nipple with integral test cap, neoprene bowl gasket, hardware, threaded rod protectors, polished chrome plated finishing cap nuts and rear anchor tie down support.

Function: Used with water closets that are offset from a common stack by 4" in multi-floor installations where minimum pipe space is required. Typical for off the floor plumbing fixtures that are wall mounted and have no contact with the finished floor. The closet carrier is completely concealed within the wall and supports the load of the fixture through a faceplate and foot support system that is anchored to the floor. Sanitation underneath the fixture is more efficiently and economically maintained when installed off of the floor compared to floor mounted

Note: 8" (203) minimum space required between front of foot and rear of anchor support.

Note: Foot supports and faceplate are assembled at the factory before shipment in the typical siphon jet water closet configuration and are reversible for the blowout water closet design.

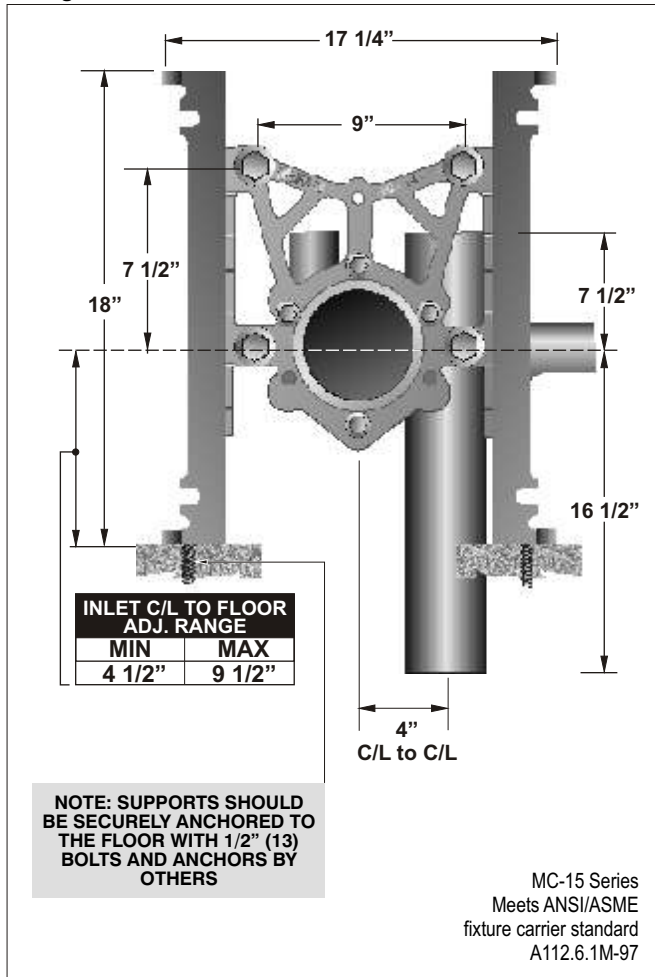

Note: 8" tapered thread ABS nipple shipped standard with MC-15 Series carriers. The universal faceplate assembly accepts all nipple variations, rolling thread (-OR), cast iron (-CI) and tapered thread ABS with adjustable horn (-AH).

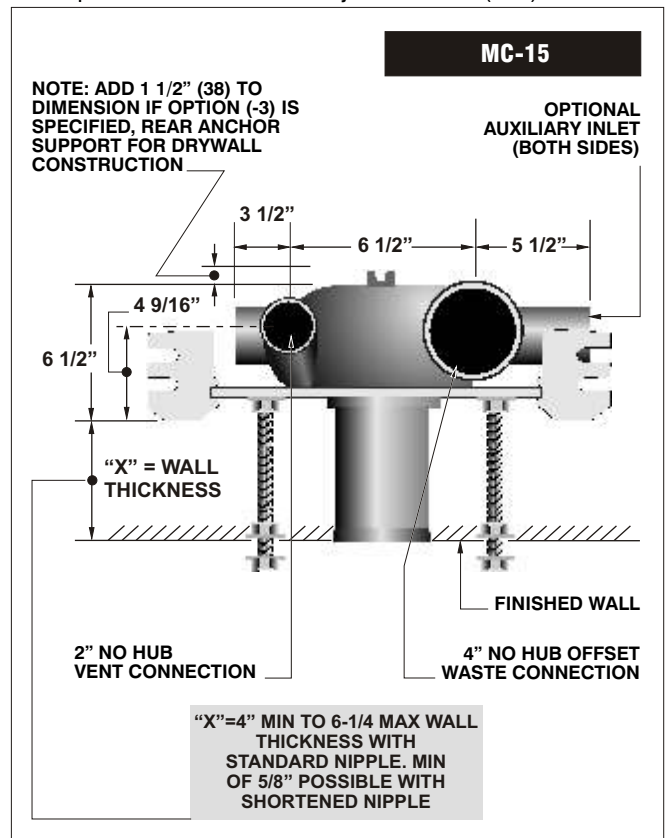

OPTIONAL VARIATIONS:

- 8" ABS nipple with adjustable horn
- 12" ABS nipple with adjustable horn
- 4" rolling thread cast iron nipple
- 6" rolling thread cast iron nipple
- 8" rolling thread cast iron nipple
- 12" rolling thread cast iron nipple
- 24" rolling thread cast iron nipple
- Extra heavy duty 500 lb. load rated carrier
- Hub and spigot connection
- 8" rolling thread ABS nipple
- 12" rolling thread ABS nipple

SUFFIX

- AH8
- AH12
- CI-4
- CI-6
- CI-8
- CI-12
- CI-24
- HD
- HS
- OR8
- OR12

SUFFIX

- Finishing / Tiling frame -1
- Auxiliary support, recommended with nipple lengths over 12" -10
- 12" tapered thread ABS nipple -12
- Test plug for custom and cast iron nipples -13
- Vandal proof finish trim -14
- Galvanized cast iron -17
- Nipple wrench -19
- Flush valve support -20
- 2" Auxiliary inlet, right side -25
- 2" Auxiliary inlet, left side -26
- Two 2" Auxiliary inlets -31

Job Name: _____ Page No: _____
 Section No: _____ Contractor: _____
 Schedule No: _____ Purchase Order No: _____