



F1100-AS

FLOOR DRAIN WITH ANGLE STRAINER FOR NON-MEMBRANE FLOOR AREAS

Internet address: www.mifab.com

Toll Free: 1-800-465-2736

Canada Toll Free: 1-800-387-3880

SPECIFICATION: MIFAB Series F1100-AS-1 lacquered cast iron floor drain with anchor flange, weepholes, and "AS" angle satin finished nickel bronze strainer. (For membrane floors, use MIFAB F1100C-AS Series).

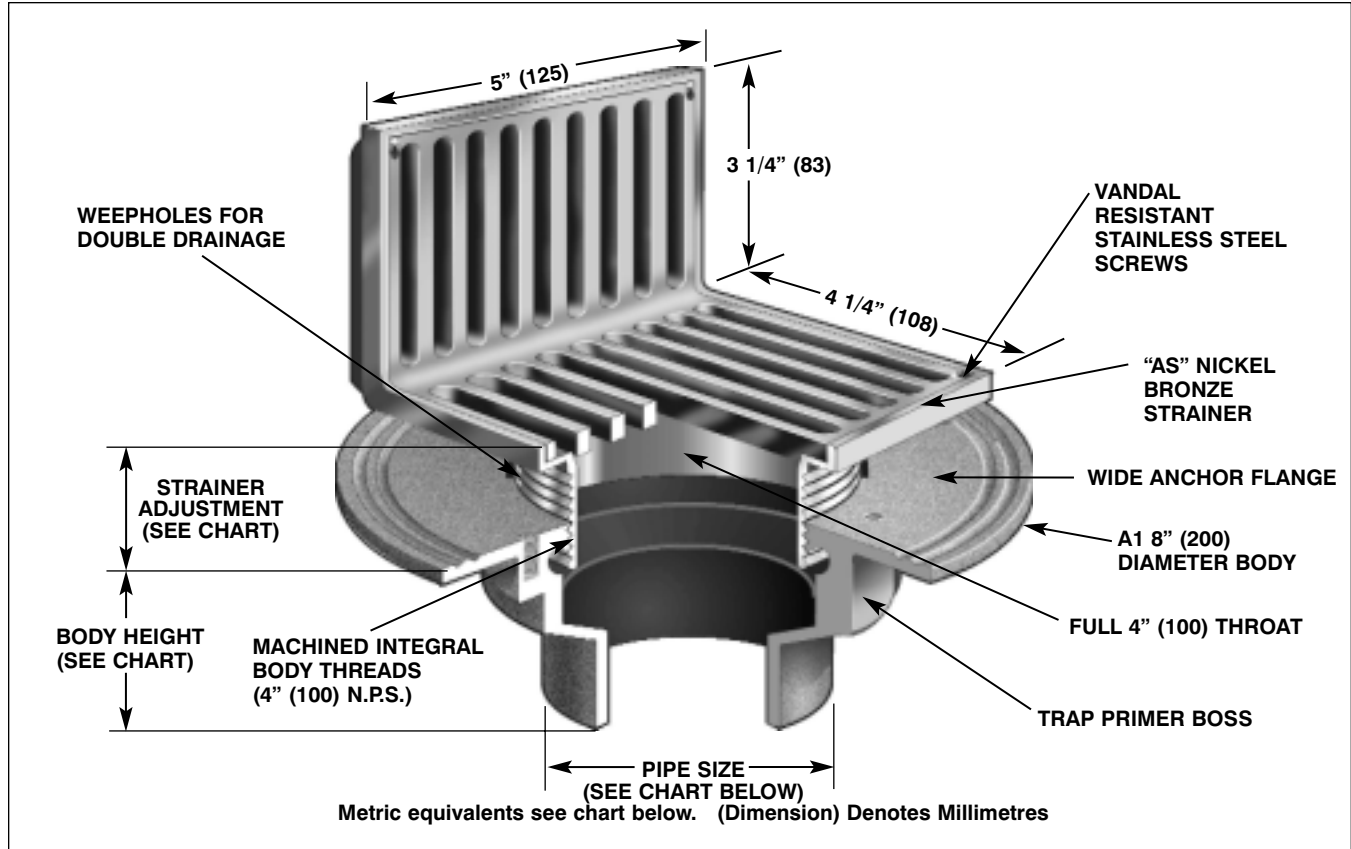

STRAINER SIZE	STRAINER ADJUSTMENT		ANSI/ASME RATING		PIPE SIZE	NO HUB	BODY HEIGHT PUSH ON (P)	THREADED (T)	INSIDE CAULK (X)
	MIN	MAX	FREE AREA	LOAD RATING N.B. (-1)					
5" x 3/4" x 4 1/4" (125) x (83) x (108)	1/2" (13)	1 5/8" (41)	30.0 in ² (19354 ²)	UP TO 2,000 LBS.	2" (50)	2 3/4" (70)	3 3/8" (86)	2 1/4" (57)	2 3/4" (70)
					3" (75)	2 3/4" (70)	3 3/8" (86)	2 5/8" (67)	2 3/4" (70)
					4" (100)	2 3/4" (70)	3 3/8" (86)	2 5/8" (67)	2 3/4" (70)
					6" (150)	3 1/4" (83)	—	—	—

OPTIONAL VARIATIONS:

- Nickel bronze
- Stainless steel strainer**
- 3M epoxy finish
- Sediment bucket
- Vandal proof
- Trap seal primer tapping
- Backwater valve
- Acid resistant epoxy coating
- All galvanized

- suffix -1
- suffix -3**
- suffix -3M
- suffix -5
- suffix -6
- suffix -7
- suffix -8
- suffix -11
- suffix -13

- Extension
- Bronze body
- Stainless steel body (type 304)
- Stainless steel body (type 316)
- PVC socket connection body**
- ABS socket connection body**
- Closure plug
- Deck clamp
- Sump receiver
- Threaded side outlet
- Client logo
- Push on outlet
- Threaded outlet
- Inside caulk outlet

- suffix -15
- suffix -27
- suffix -28
- suffix -29
- suffix -30**
- suffix -31**
- suffix -34
- suffix -40
- suffix -41
- suffix -90
- suffix -95
- suffix P
- suffix T
- suffix X

PARTS:



A1 BODY



AS-1