

Specification: MIFAB® C220 Series (specify top assembly design) adjustable floor cleanout with lacquered cast iron body, secondary closure plug and scoriated combined cover and plug top assembly (specify material type) with stainless steel vandal proof allen key screws.

Function: Used in finished floors to provide emergency access to the plumbing lines for removal of blockages.

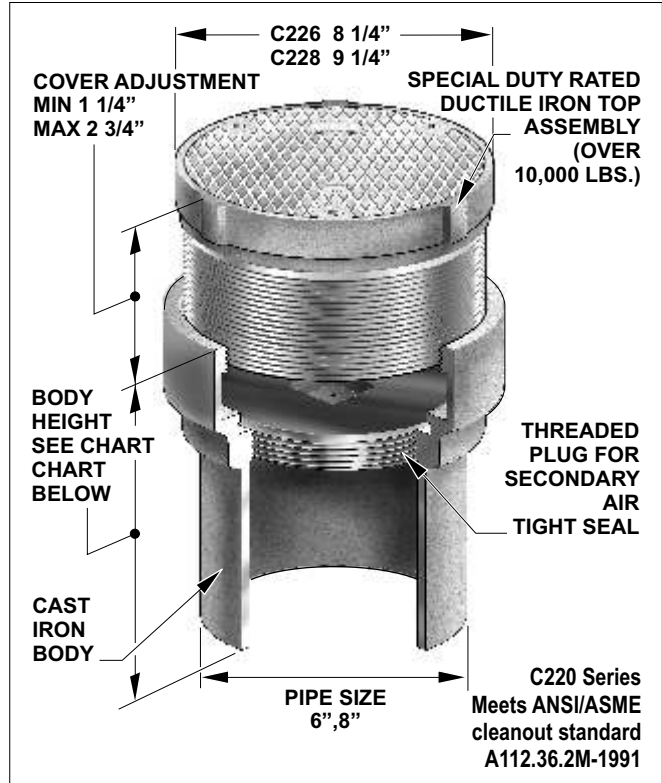
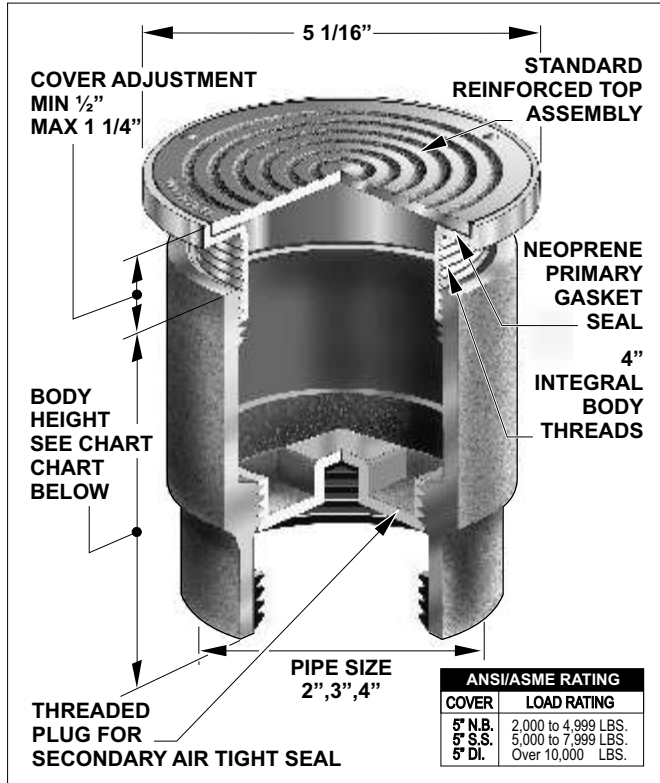

Metric equivalents see chart below. (Dimension) Denotes Millimetres

Note: C226X has a 9 1/4" Dia. top assembly

ANSI/ASME RATING	
COVER	LOAD RATING
5" N.B.	2,000 to 4,999 LBS.
5" S.S.	5,000 to 7,999 LBS.
5" DI.	Over 10,000 LBS.

PIPE SIZE	BODY HEIGHT			
	NO HUB (STANDARD)	PUSH ON (P)	INSIDE CAULK (X)	PVC/ABS (-30)/(-31)
2" (51)	4" (102)	4 3/8" (111)	-	3 5/8" (92)
3" (76)	4" (102)	4 3/8" (111)	-	4 5/16" (109)
4" (102)	4" (102)	4 3/8" (111)	-	4 5/16" (109)
6" (152)	7 1/2" (191)	-	6 7/8" (175)	-
8" (203)	7 1/2" (191)	-	-	-

OPTIONAL VARIATIONS:

- Nickel bronze top assembly (standard) -1
- Heavy duty stainless steel to assembly -3
- Extra heavy duty ductile iron top assembly for unfinished areas -4
- Security screws (T-20 torx and pin) -6
- Acid resistant epoxy coating -11
- All galvanized -13
- Extension (2", 3", 4" outlets only) -15
- PVC socket connection body (2", 3", 4" outlets only) -30
- ABS socket connection body (2", 3", 4" outlets only) -31

- Brass closure plug -34B
- Client logo -95
- No hub outlet (Standard)
- Push on outlet (2", 3", 4" outlets only) P
- Round top assembly -R
- Stainless steel carpet marker -RC
- Stainless steel carpet flange cover (-1 or -3 only) (2", 3", 4" outlets only) -RCF
- Square top assembly (-1 or -3 only) (2", 3", 4" outlets only) -S
- Round top assembly recessed 1/8" for tile (-1 or -3 only) (2", 3", 4" outlets only) -T

SUFFIX

- Square top assembly recessed 1/8" for tile (-1 or -3 only) (2", 3", 4" outlets only) -TS
- Round top assembly recessed 1 1/4" for terrazzo (-1 or -3 only) (2", 3", 4" outlets only) -UR
- Square top assembly recessed 1 1/4" for terrazzo (-1 or -3 only) (2", 3", 4" outlets only) -US
- Inside caulk outlet (6" outlet only) X
- Heavy duty nickel bronze top assembly -XR-1
- Extended wide elastomeric flange -Z

Job Name: _____	Page No: _____
Section No: _____	Contractor: _____
Schedule No: _____	Purchase Order No: _____