



**C1230**

**LINE OR FLOOR CLEANOUT**

Internet address: [www.mifab.com](http://www.mifab.com)

Toll Free: 1-800-465-2736

Canada Toll Free: 1-800-387-3880

**SPECIFICATION:** MIFAB Series C1230 lacquered cast iron cleanout ferrule with 1/2" (13) thick gasketed combined ductile iron cover and plug.

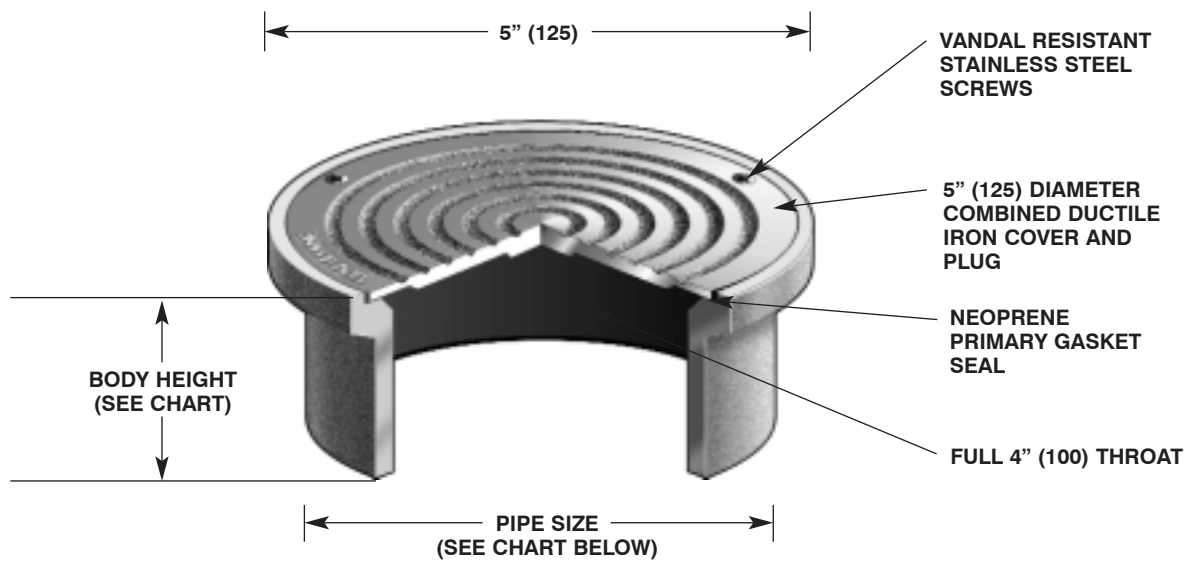

C1230 SERIES MEETS  
ANSI/ASME CLEANOUT  
STANDARD A112.36.2M-1991.

COVER DIAMETER	ANSI/ASME RATING		PIPE SIZE	BODY HEIGHT			
	LOAD RATING			CAST IRON BODY (NH)	NICKEL BRONZE BODY (-1)	PVC BODY (-30)	ABS BODY (-31)
	N.B. (-1)	D.I. (-4)					
5" (125)	UP TO 4,999 LBS.	UP TO 7,499 LBS.	2" (50)	2 3/16" (56)	2 3/16" (56)	2 5/8" (67)	2 5/8" (67)
			3" (75)	2 3/16" (56)	2 3/16" (56)	2 5/8" (67)	2 5/8" (67)
			4" (100)	2 3/16" (56)	2 3/16" (56)	2 5/8" (67)	2 5/8" (67)

**OPTIONAL VARIATIONS:**

- Nickel bronze body and cover                      suffix -1
- Ductile iron cover (standard)                      suffix -4
- Vandal proof    suffix -6
- Acid resistant epoxy coating                      suffix -11
- All galvanized    suffix -13
- PVC body**    **suffix -30**
- ABS body**    **suffix -31**
- Closure plug    suffix -34
- Elastomeric flange                                    suffix -Z