

# What's Happening In March

## Spotlight on Bill Ross, Siphonic Drainage Guru

This month, we will take a look at **Bill Ross, Director of HydroMax, Ltd.** Born in Dundee, Scotland and educated at Dundee Technical College to become a Technician Plumber. Having worked in the Plumbing Industry his entire career, Bill became a Director of Ross ADT in 1987. In early 1990's Bill was extensively trained in Siphonic Roof Drainage system design and Installation techniques and has specialized in Siphonic Roof Drainage ever since. Bill led the development of the HydroMax system and HydroTechnic hydraulic design program. Bill contributed to the British Standards for Siphonic Roof Drainage and served on the ASPE committee for the original ASPE Siphonic Drainage Standard 45:2007 and ASPE/ANSI Siphonic Drainage Standard 45:2013.

### 1. Tell us a little about HydroMax™?

HydroMax is a technology based company owning the Intellectual Property for the HydroMax™ siphonic roof drainage system consisting the bespoke range of HydroMax™ drains and our HydroTechnic™ analytical design calculation program.

### 2. How did you come about starting HydroMax and long has HydroMax been in operation?

HydroMax™ siphonic roof drainage was launched in 2003 following siphonic roof drainage being introduced into the British Standard appendix to the European Norm Standard published in 2000 which we believe was the first published standard including siphonic roof drainage. Our company at that time was Ross ADT which was a large plumbing contractor business that adopted siphonic roof drainage as a new forward thinking technology. Ross ADT had been designing, supplying and installing siphonic drainage from the early 1990's. When we changed our strategy to move into international markets, we changed the business model to work with local partners and pulled out of the installation business. Following this transition in mid-2000's we started HydroMax Incorporated Limited in 2006.

### 3. What was your background prior to working with HydroMax?

I had worked in our family Plumbing Contractors business which was one of the country's largest plumbing contractors. I went to Switzerland in the early 1990's to learn about siphonic roof drainage and had over 10 years' experience selling two different product offerings before setting out to develop HydroMax™ .

### 4. You've been successful with HydroMax...tell us a little about what you did to initiate that success and how you maintain that success.

Using our experience, we developed HydroMax™ to have market leading drains in terms of quality, simplicity in design and measurable performance. Our HydroTechnic™ analytical design calculation

**Please See Bill, Pg. 2**

## In The March Issue:

<b>Spotlight - Bill Ross</b>	<b>1</b>
<b>HydroMax Testimonial</b>	<b>3</b>
<b>Community Roundup</b>	<b>4</b>



## **Bill Con't from Pg. 1**

program was developed after consultation with the testing authority commissioned by the UK government (HR Wallingford) to be the most accurate calculation program available. Additionally, we had the knowledge of what was required by design engineers and ensured that the features and functions were packaged into a user-friendly program. We then re-wrote the program to be an Internet hosted program to allow ease of access and assistance to users.

## **5. Is there any advice you can give to our customers?**

HydroMax™ is tried, tested and proven technology to provide real value engineering as it provides technical benefits at the same time as realizing cost savings.

WalMart uses HydroMax™ as its exclusive siphonic roof drainage product. WalMart reviewed all alternates available and concluded HydroMax™ was the best product with the best technology and software and have used HydroMax™ for over 10 years on approximately 900 stores.

## **6. How do you see MIFAB HydroMax expanding in the future?**

Our sales and marketing efforts will major on the education and promotion at the highest levels.

The use of siphonic drainage is growing in the USA and we will be continuing to educate engineers but also concentrating on end user Clients and Architects. As we have grown with an ever expanding list of projects in most AHJ's, it is easier to convey local projects taking advantage of the technology and with clients and their design teams being conservative, they are appreciating how safe and beneficial Mifab HydroMax™ is leading to a growth in the number of projects being designed with siphonic drainage.

## **7. What do you see as the most important information for our representatives to know?**

HydroMax™ siphonic roof drainage is safer (efficient rainwater removal achieves reduced water depths on the roof). There are many technical benefits. The system costs significantly less.

## **8. Is there a particular job that sticks out in your mind that you'd like to share?**

There are so many to choose from! I suppose one that shows savings from eliminating products that were required by traditional gravity drainage restrictions is Marina Heights in Tempe AZ which is a mixed use project with acres of Plaza/Promenade deck where the original design included a gravity drainage solution to the deck. Due to the large Gravity pipe diameters and sloping pipework, the drainage could not reach the perimeter site civils drainage connections. As such, the gravity design required several collecting tanks and pumping stations costing in excess of \$200k (in addition to taking up a large volume of valuable building space). The design was converted to a HydroMax™ siphonic solution as it achieved the deletion of tanks and pumps by running long distances flat to the required discharge location.

## **9. Do you have any closing comments or suggestions for our representatives?**

MIFAB HydroMax™ is a safe way of realizing many technical benefits while obtaining significant cost savings. We have the tools and support to help you design the optimum solution and we have market leading products which will bring many years of efficient rainfall removal. Come to Mifab HydroMax™ and we will walk you through the procedures and provide free of charge access to our HydroTech™ calculation program.

We expect a lot from our strategic partnership with Bill Ross AND HydroMax™. If you have any questions regarding Hydromax or Siphonic Roof Drainage technology, please contact your RSM!



## Another Satisfied HydroMax™ Customer Writes:

We recently received yet another testimonial letter from a satisfied customer regarding **Hydromax® Siphonic Roof Drains**. It reads:

“In the course of the challenging storm design for the Embry Riddle Aeronautical University Student Union Building, HydroMax Siphonic Drainage enabled us to achieve a design solution that conventional storm system could not offer. We were enabled to incorporate smaller size cast iron, PVC and copper pipes within the HydroMax Siphonic system which provided technical benefits as well as cost savings.”

KAZ KAZEMINIA  
Principal/Director of Plumbing & Fire Protection Engineering



A telling Testimonial! Let's get excited about our strategic partnership with **Hydromax® Siphonic Roof Drains**.

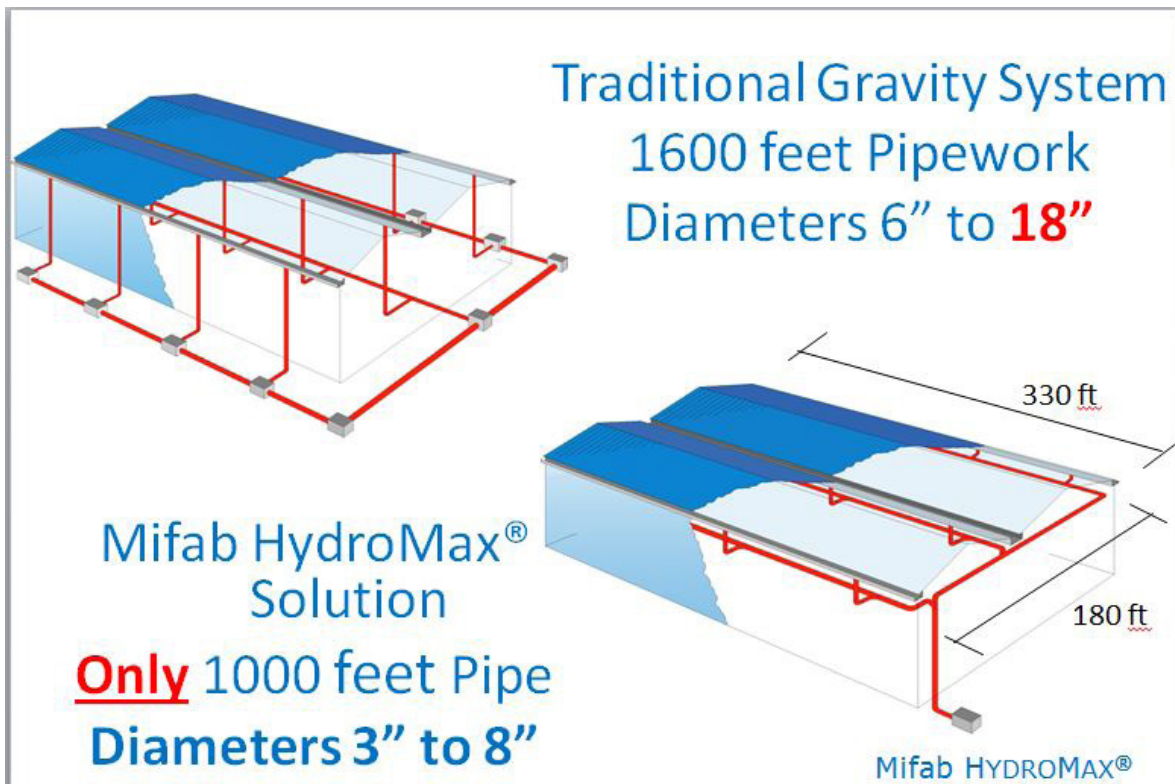

# MIFAB Matters - What's Happening at MIFAB This Month!

## Welcome Aboard!

**MIFAB** is pleased to announce the additions of two new members to our Team:

**Ronald Vlk**, Chief Operations Officer

**Patricia Nilles**, Customer Service Representative

Both come to MIFAB with extensive backgrounds in the Commercial Plumbing Products Field. Welcome to MIFAB!



**Patricia Nilles**



**Ron Vlk**



## Upcoming Shows & Meetings:

**MIFAB** will have a presence at the following Meetings & Organizations:

**WIT Distributor/Vendor Conference 2016**, Dallas TX, March 7th - 11th

**MCAA Annual Convention 2016**, Orlando FL, March 22nd

