



Distributed by:  MIFAB



Product Catalog

AV - P

# AV - P

Air Release & Air and Vacuum Valves



AV - P  
(Plastic Air Valves)

**General**

The presence of trapped air in a pressurized pipeline can have serious effects on system operation and efficiency. As air pockets accumulate at high points, they reduce the effective cross-section of the pipeline in their location, decreasing the water flow, and increasing energy consumption required to pump the water through. Thus reducing the overall system efficiency. A pipeline with many air pockets may impose enough restriction to stop all flow (“airlocks”).

The dislodge and movement of the air pockets may change suddenly the fluid velocity and cause pressure surges and pipeline ruptures.

Trapped air pockets may also accelerate corrosion in the pipe material, damage water metering devices and cause erratic operation of control valves.

On the other hand, when a system is being drained there is a necessity to admit atmospheric air into the pipeline in order to occupy the volume of drained water so to prevent dangerous sub-atmospheric pressure in the pipeline that may bring to complete collapse of pipe-sections.

**Pipeline Without Air Release Valves**

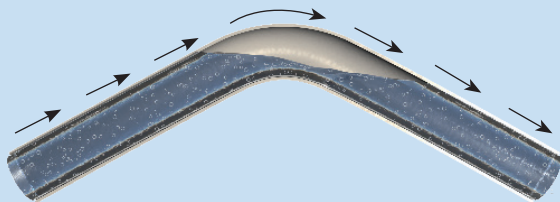

Pressurized air may be trapped at local high points of the pipeline

- Increases head loss
- Decreases flow rate
- Increases energy consumption

**Pipeline Without Air and Vacuum Valve**

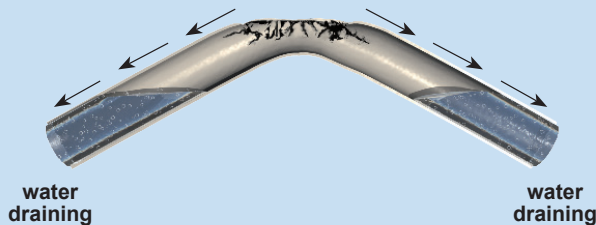

Sub atmospheric pressure is created due to pump shutdown or surges conditions

- Contaminants may be sucked into the system
- Thin-walled pipes may collapse
- Vapor pockets can form

After each stoppage of deep-well (borehole) pump, the riser drains from water and should be filled with air. At startup, the water column in the pipe rises rapidly, and in the absence of an air-valve the pressurized air may be forced through the surface check-valve into the main header. Additionally, once the riser is full with water, the sudden increased resistance may cause pressure surges.

**Vertical Pump Discharge Without Air Release Valve**

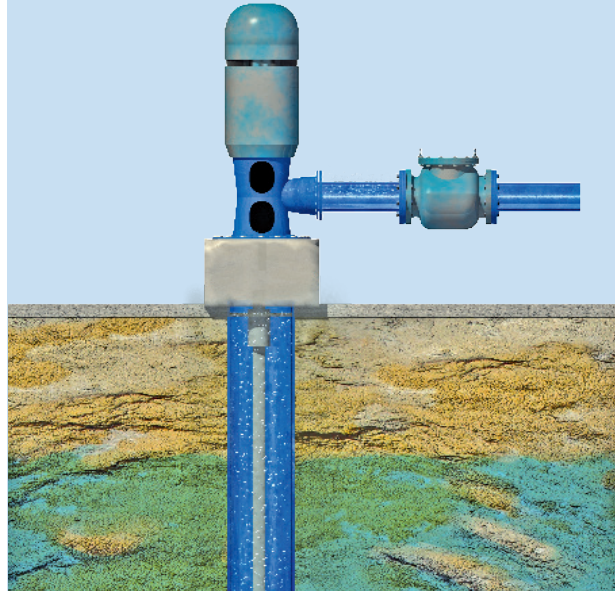

The riser of a deep-well pump is filled and drained with water when the pump is operated or stopped. Air must be admitted into and out of the riser.

- Surges in pipe column
- Entry of large volumes of air into the system
- Potential vacuum

**Primary Sources for Air in Water-Charged Pipelines**

- Atmospheric air that was trapped within the pipe-system when the pipeline was filled with water. With absence of air discharge devices, this would normally accumulate at local elevated points in the system or vent through customer tapping points.
- Water at normal pressure and temperature can contain approximately 2% (by volume) of dissolved air. The water flow is subjected to varying pressures and temperatures, due to the terrain slopes, variations in flow velocity caused by changing pipe diameters, partially-open valves, etc. and the dissolved air may be released from the water mass, accumulating as large pockets of air in the local peaks.
- Air may be drawn into the pipeline at start-up of deep-well pumps, by the pump suction-vortexes and through leaking joints at zones above the hydraulic gradients (negative-pressure points). Air can also be admitted into the system by air valves under sub-atmospheric pressure conditions.

The Types and Functions of Air Valves:

**Air and Vacuum Valves:**

- Exhaust large quantities of air from the pipeline when it is filled with water at low pipeline pressure.
- Admit large quantities of air into the pipe when it is drained, or when the internal pressure drops below atmospheric pressure due to transient conditions.

**Air Release Valves:**

- Release small pockets of accumulated air while the pipeline operates under pressure.

**Combination Air Valves:**

- A valve that performs both the Air Release and Air and Vacuum functions.

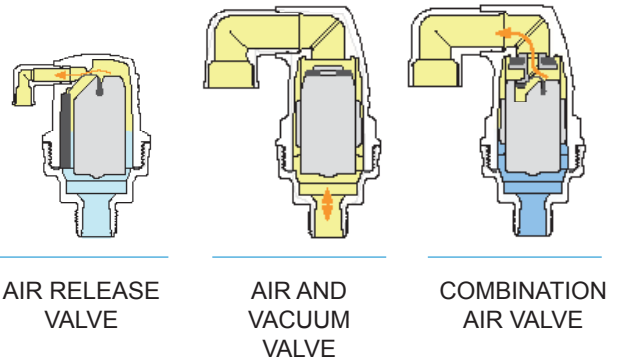

Air Valve locations along a pipeline:

1. High points (relative to hydraulic gradient line).
2. Increase in a downward slope.
3. On uniform, long pipe sections: horizontal run, long descents. Air valves should also be located at even spaces of few hundreds of meters (500 to 1000), as determined by collapse-potential of the pipeline under negative pressure.
4. When the flow velocity is very low, air pockets may accumulate in each local peak, even in small ones, and in steep downhill slopes. It is recommended to eliminate these restrictions by installing air release valves.
5. On the discharge side of deep-well pumps and vertical urbine pumps.
6. Both sides of canal and bridge crossings.
7. Both sides of check-valves, isolating valves and any device that may be closed in the water system, where air may accumulates on one side while vacuum may be created on the other side.
8. Downstream of a pressure reducing device
9. At any point where the air may accumulate due to local pressure change.
10. At any point where sub-atmospheric conditions may occur during normal or transient conditions.

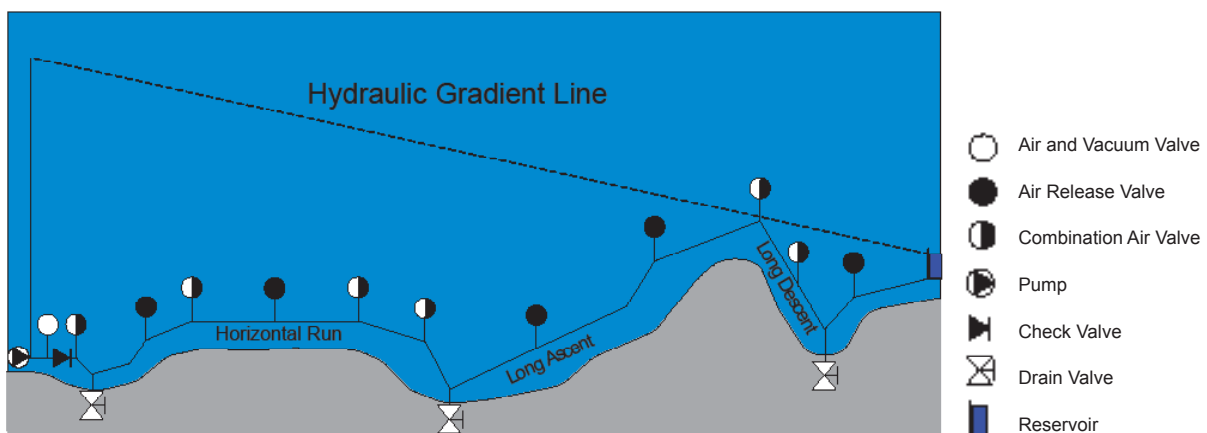

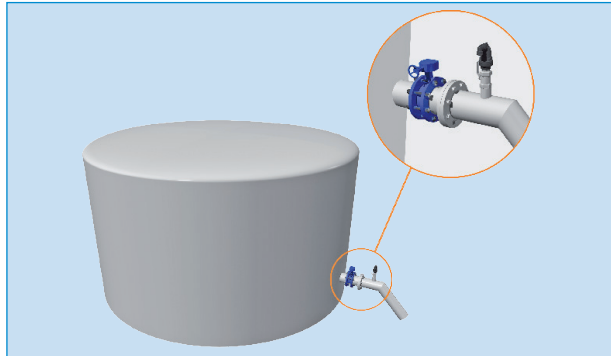

Outlet of reservoir, downstream of the check valve

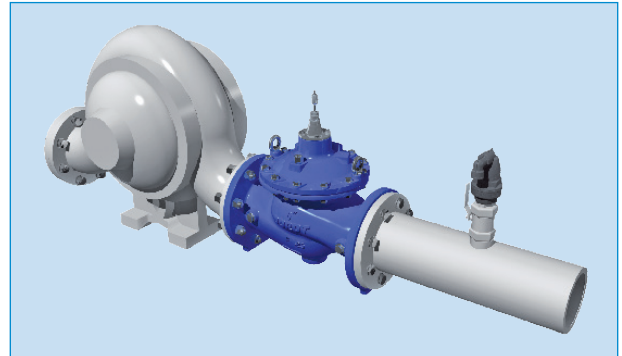

Discharge side of pumps, subsequent to a non return valve

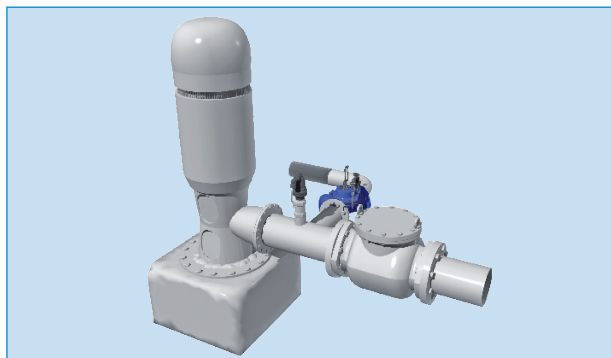

Discharge side of vertical turbine pumps, subsequent to a non return valve

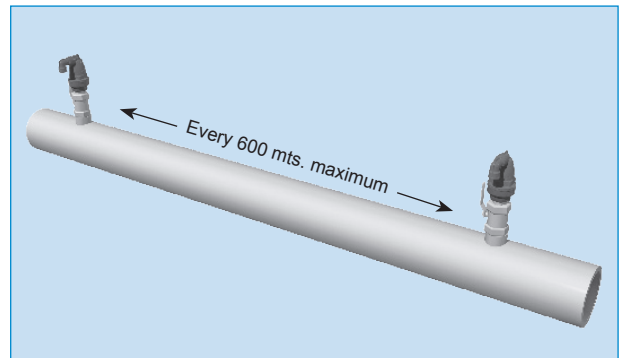

On uniform, long pipe sections: horizontal run, long descents, and long ascents

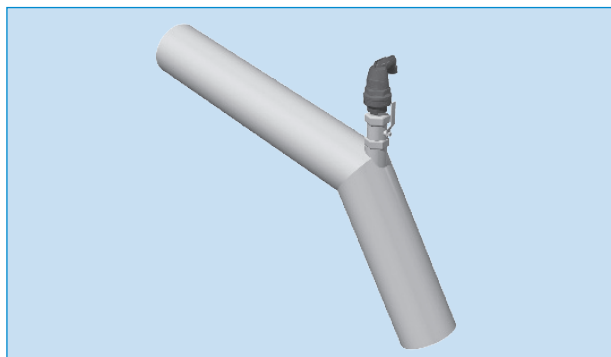

Negative breaks: increase in a downward slope

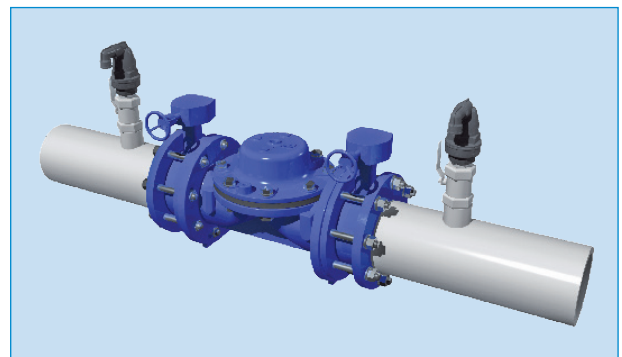

Downstream of a pressure reducing device

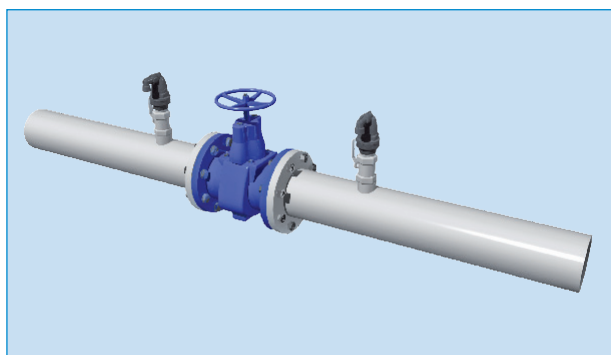

Both sides of check-valves, isolating valves or any device that may be closed

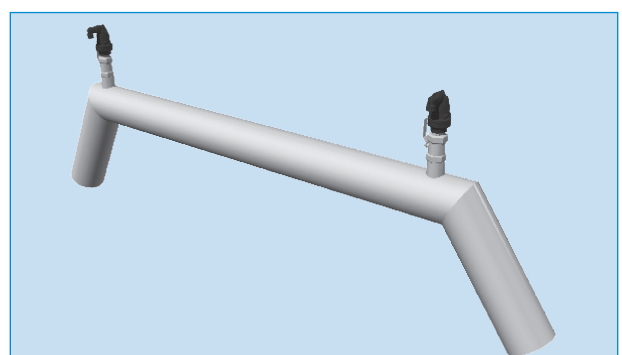

Both sides of canal and bridge crossings

**Sizing principles:**

The volumetric air flow through the air valve is equal to the flow rate of the water filling or emptying the system:

For each volume of water entering the pipeline, the same volume of air must be expelled, and similarly, for each volume of water drained from the system, the same volume of air should be admitted into the line.

**Note:** Air is a compressible media, so its density and volume vary with the pressure. The term “volumetric flow” noted above, refers to the volume of air inside the pipeline. It is smaller than the ‘standard’ (atmospheric pressure) air flow when the system is being charged with water, and larger than the ‘standard’ flow when the system is being drained. The tables and charts presented in this catalogue present the standard air flow under atmospheric pressure.

The air flow velocity in the valve depends on three factors:

- a. Rate of water flow, at the valve site
- b. Orifice Diameter of the valve
- c. Geometry of the specific valve
- d. Pressure differential between the pipe and the atmosphere

The air flow-velocity through the valve can reach very high values, due to its low density. It is limited only when the velocity reaches the sonic speed, which is practically impossible for the ‘Air and Vacuum’ valve type, but is the

normal situation in the case of the ‘Air Release’ valve type. When the system’s internal pressure reaches 0.89 barg, the volumetric air-flow through the orifice becomes constant (critical, sonic-velocity). Increase of the pressure will not result in increased volumetric-flow, though standard air-flow will continue to increase.

As a rule of thumb, the initial design value for air valves should allow maximal  $\Delta H$  of 0.1 barg across the valve. i.e. pipeline pressure which does not exceed 0.1 bar gauge-pressure while the pipe is filled, or -0.2 barg when it is drained.

However, each system must be inspected to its specific conditions, which the main one is the risk of collapse under sub-atmospheric pressures.

Too small orifice results in high air velocity that may cause:

1. Premature closure, before the water reaches the valve
2. A mechanical slam of the float to its seating area when the water has reached the valve, local water-hammer and possible breakage of the valve.
3. Too-small air valve may cause too low sub-atmospheric pressure, which in turn may cause ingress of contaminants into the system and even pipe-collapse.

**Ordering guide:**

**PLASTIC WATER SERVICE AIR RELEASE VALVES**

AV-SIZE-P	- TYPE
AV.50-P	- A Air Release
AV.75-P	- K Air and Vacuum
AV1.00-P	- KA Combination Air Release & Air and Vacuum
AV2.00-P	

**ORDERING GUIDE EXAMPLE**

AV2.00-P	- KA
----------	------

Note: 2" available with -K or -KA functions only



**AV-P-A**

The valve is designed for an efficient release of entrapped air from the pipeline, while the network is at normal working pressure.

Due to the relatively large orifice, compare to other Automatic valves in the market, it can also release the air through initial filling of a small-diameter pipe, or admit air into it while it is drained.

**Properties:**

An Automatic air valve, that enables the release of dissolved air that accumulate in the pipeline. The valve will release the air at normal operation pressures of the pipeline.

The Float is made of naturally-buoyant material (specific weight lower than 1).

The float activates a sealing stripe, that closes the outlet when the water will fill the valve body.

On accumulation of air in the valve, loss of buoyancy causes the float to drop and to pull the strip, thus opening of the air outlet.

The Hydraulic sealing of the orifice will provides a drip-tight closure at a pressure of 3psi.

**Operation:**

Releasing entrained air from the pipeline. Small quantities of diluted air accumulate in high peaks of the pipeline and in the peak of the valve.

The pressurized air expels the water. The descending water level moves the main float with it. At a certain position the main float pulls down the small seal, that partially opens the nozzle.

The pressurized air can escape, the water level rises and the nozzle re-closes.

**Technical Specifications:**

- Operating pressure 3 -250 PSI
- 1/2", 3/4", 1" MNPT Connection
- Structure materials: Cover: GRP (UV resistant), Base: GRP or Brass
- Internal parts: corrosion resistant, reinforced plastic materials and synthetic rubber
- 1/2" MNPT Part No.: AV.50-P-A
- 3/4" MNPT Part No.: AV.75-P-A
- 1" MNPT Part No.: AV1.00-P-A

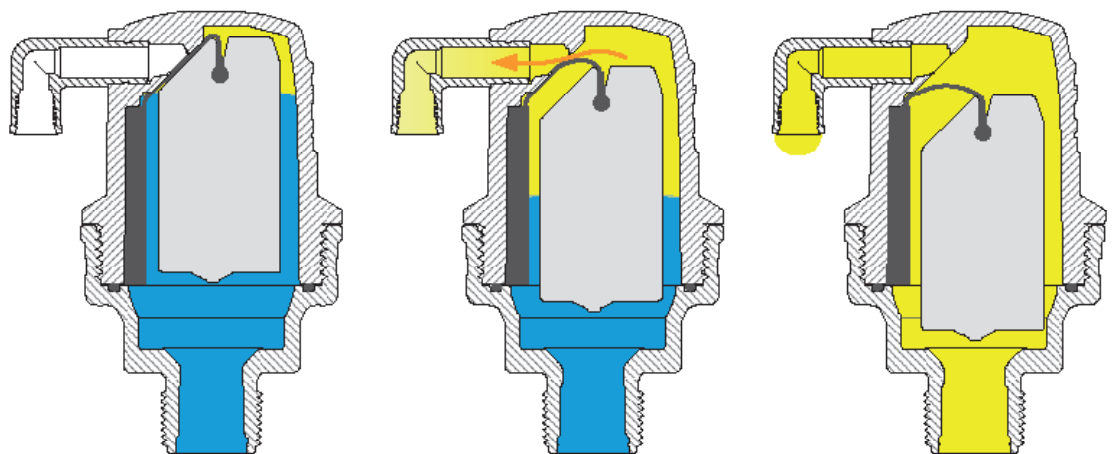
**Principle of operation:**

Pipe is full of water

Dissolved air is accumulated in the valve, released when the float drops down

Pipe is aerated

### Parts list and specifications:

Part	Description	Material
1	Base	Glass Reinforced Nylon Optional: Brass
2	Cover	Glass Reinforced Nylon
3	Float	Foamed Polypropylene
4	Seal	Silicon
5	O ring	NBR
6	Drainage Elbow	Polypropylene

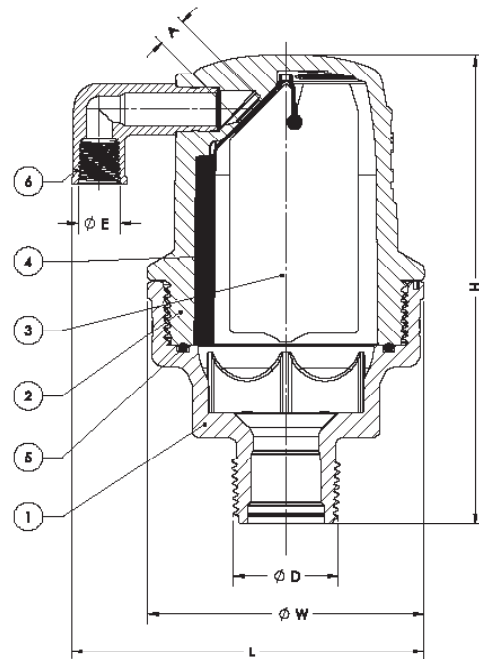

### Dimensions:

Valve	1/2"	3/4"	1"
Dimension	US	US	US
H - Height	5 <sup>3</sup> / <sub>4</sub> "	5 <sup>3</sup> / <sub>4</sub> "	5 <sup>3</sup> / <sub>4</sub> "
W - Width	3 <sup>1</sup> / <sub>3</sub> "	3 <sup>1</sup> / <sub>3</sub> "	3 <sup>1</sup> / <sub>3</sub> "
D - Thread	1/2" NPT	3/4" NPT	1" NPT
A - Nozzle Area	0.02 in <sup>2</sup>	0.02 in <sup>2</sup>	0.02 in <sup>2</sup>
L - Total Width	4 <sup>1</sup> / <sub>3</sub> "	4 <sup>1</sup> / <sub>3</sub> "	4 <sup>1</sup> / <sub>3</sub> "
E - Drainage Diameter	1/4"	1/4"	1/4"
Weight	0.88 lbs.	0.88 lbs.	0.88 lbs.

### Performance:

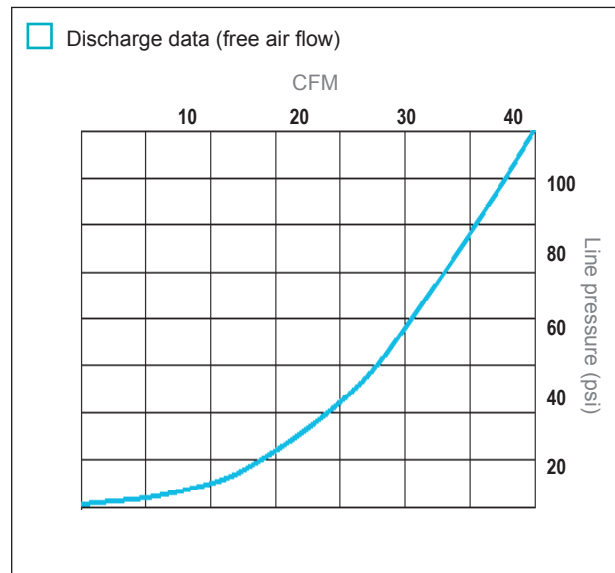
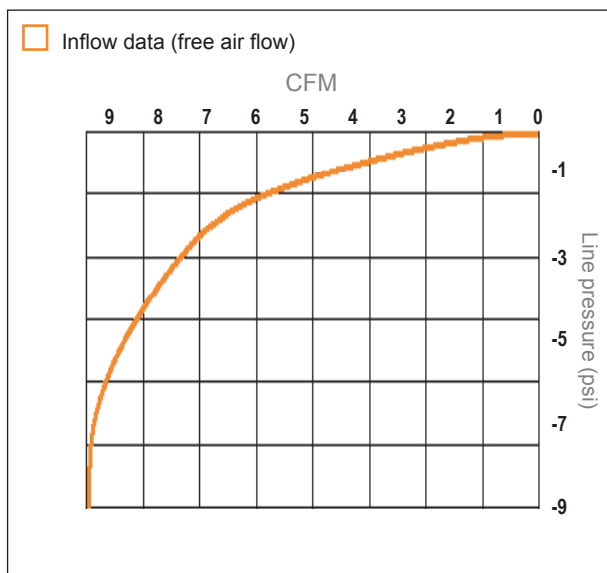

**AV-P-K**

This valve has been designed for efficient discharge and intake of air in water transport systems, filtering systems, containers, and other places where confined air could impair the system's operation.

The valve is appropriate for:

- Expelling the air at high flow velocity during the initial filling of the system
- Introducing large quantities of air when the pipe drains, maintaining atmospheric pressures in the pipe and preventing collapse and cavitation damage to the conduits

**Properties:**

Leak-proof sealing at all conditions, including low system pressure. The aerodynamic design of the float provides air flow at a very high velocity. The float does not close before the water has reached the valve. Threaded outlet elbow allows various possibilities of drain connection. The valve design contains a very limited number of parts, allowing easy dismantling for maintenance.

**Operation:**

The AV-P-K valve has two modes of operation:

Discharge of large quantities of air at a high flow velocity when the conduit is being filled. When the water arrives to the valve, the float rises up and closes the outlet.

Introduction of air into the pipeline when the internal pressure is sub-atmospheric. The pressure difference forces the float to drop to "opened" position, allowing large volumes of air to flow into the pipe.

**Technical Specifications**

- Operating pressure of 3 -250 PSI
- 1/2", 3/4", 1" and 2" MNPT Connection
- Structure materials: Cover: GRP (UV resistant), Base: GRP or Brass
- Internal parts: corrosion resistant plastic materials and synthetic rubber

1/2" Part No.: AV.50-P-K

3/4" Part No.: AV.75-P-K

1" Part No.: AV1.00-P-K

2" Part No.: AV2.00-P-K

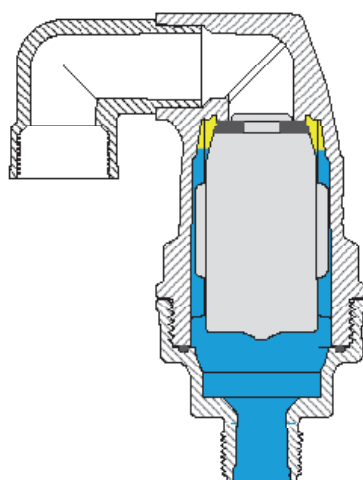
**Principle of operation:**

Pipe is full of water

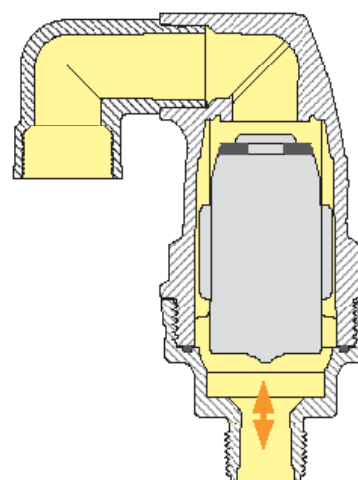

Pipe is aerated



### Parts list and specifications:

Part	Description	Material
1	Body	Glass Reinforced Nylon Optional: Brass
2	Bonnet	Glass Reinforced Nylon
3	Float	Foamed Polypropylene
4	Seal	EPDM Rubber
5	O ring	NBR
6	Drainage Elbow	Polypropylene

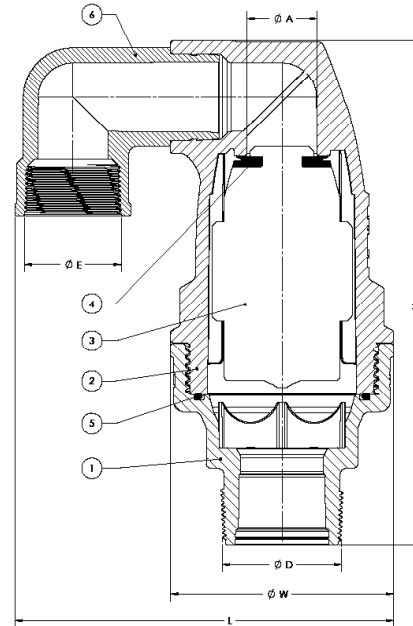

### Dimensions:

Valve	1/2"	3/4"	1"	2"
Dimension	US	US	US	US
H - Height	7 1/4"	7 1/4"	7 1/4"	9 7/8"
W - Width	3 1/3"	3 1/3"	3 1/3"	4 1/3"
D - Thread	1/2" NPT	3/4" NPT	1" NPT	2" NPT
A - Nozzle Area	0.49 in <sup>2</sup>	0.49 in <sup>2</sup>	0.49 in <sup>2</sup>	1.41 in <sup>2</sup>
L - Total Width	5 1/4"	5 1/4"	5 1/4"	7 3/8"
E - Drainage Diameter	3/4"	3/4"	3/4"	1 1/2"
Weight	1.04 lbs.	1.04 lbs.	1.04 lbs.	2.32 lbs.

### Performance:

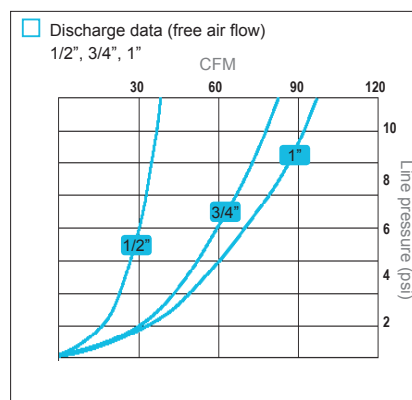
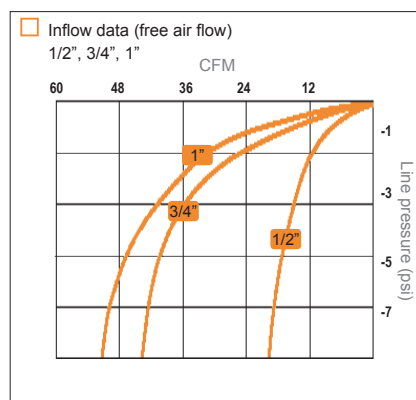
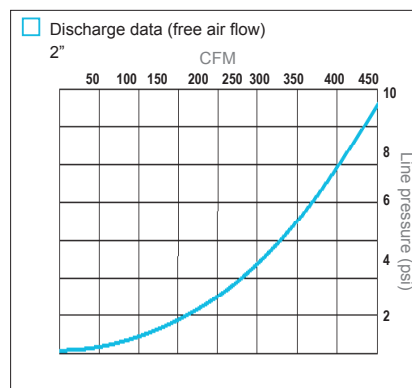
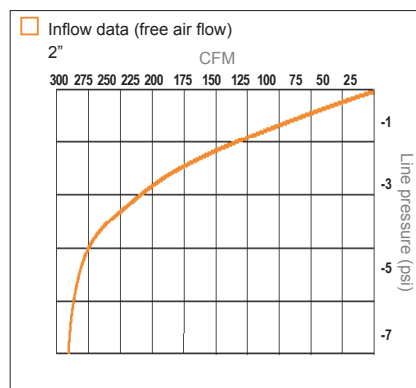

## AV-P-KA

This valve has been designed for efficient discharge and intake of air in water transport systems, filtering systems, containers, and other places where confined air could impair the system's operation.

The valve is appropriate for:

- Expelling the air at high flow velocity during the initial filling of the systems
- Introducing large quantities of air when the pipe drains, maintaining atmospheric pressures in the pipe and preventing collapse and cavitation damage to the conduits
- Relieving the entrained air from the water, while the network is pressurized

### Properties:

Leak-proof sealing at all conditions, including low system pressure. The aerodynamic design of the float provides air flow at a very high velocity. The float does not close before the water has reached the valve. Threaded outlet elbow allows various possibilities of drain connection. The valve design contains a very limited number of parts, allowing an easy dismantling for maintenance.

### Operation:

The AV-P-KA valve has three modes of operation: Discharge of large quantities of air at a high flow velocity when the conduit is being filled. When the water arrives to the valve, the main float rises up and closes the outlet. Introduction of air into the pipeline when the internal pressure is sub-atmospheric. The pressure difference forces the main float to drop to "opened" position, allowing the air to flow into the pipe. Releasing entrained air from the pipeline. Small quantities of diluted air accumulate in high peaks of the pipeline and in the peak of the valve. The pressurized air expels the water. The descending water



level moves the main float with it. At a certain position the main float pulls down the small seal, that partially opens the nozzle. The pressurized air can escape, the water level rises and the nozzle re-closes.

### Technical Specifications

- Operating pressure of 3 to 250 psi
- 1/2", 3/4", 1", 2" MNPT connection
- Structure materials: Cover: GRP (UV resistant), Base: GRP or Brass
- Internal parts: corrosion resistant plastic materials and synthetic rubber

1/2" Part No.: AV.50-P-KA

3/4" Part No.: AV.75-P-KA

1" Part No.: AV1.00-P-KA

2" Part No.: AV2.00-P-KA

### Principle of operation:

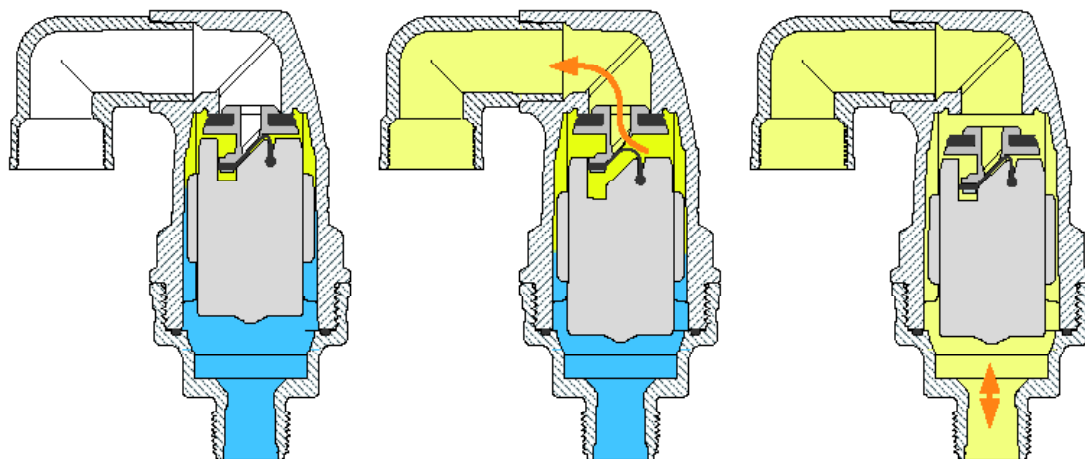

Pipe is full of water

Dissolved air is accumulated in the valve, released when the float drops down

Pipe is aerated

Parts list and specifications:

Part	Description	Material
1	Body	Glass Reinforced Nylon Optional: Brass
2	Bonnet	Glass Reinforced Nylon
3	Float	Foamed Polypropylene
4	Slider	Glass Reinforced Nylon
5	Automatic Seal	Silicon
6	Seal	EPDM Rubber
7	O ring	NBR
8	Drainage Elbow	Polypropylene

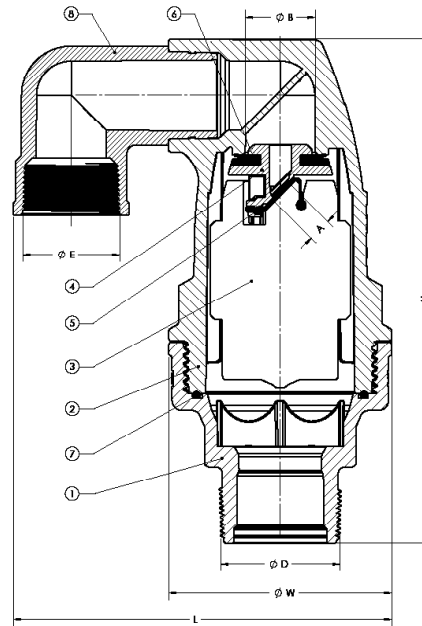

Dimensions:

Valve	1/2"	3/4"	1"	2"
Dimension	US	US	US	US
H - Height	7 1/4"	7 1/4"	7 1/4"	9 7/8"
W - Width	3 1/3"	3 1/3"	3 1/3"	4 1/3"
D - Thread	1/2" NPT	3/4" NPT	1" NPT	2" NPT
A - Nozzle Area	0.02 in <sup>2</sup>	0.02 in <sup>2</sup>	0.02 in <sup>2</sup>	0.02 in <sup>2</sup>
K - Nozzle Area	0.49 in <sup>2</sup>	0.49 in <sup>2</sup>	0.49 in <sup>2</sup>	1.41 in <sup>2</sup>
L - Total Width	5 1/4"	5 1/4"	5 1/4"	7 3/8"
E - Drainage Diameter	3/4"	3/4"	3/4"	1 1/2"
Weight	1.04 lbs.	1.04 lbs.	1.04 lbs.	2.32 lbs.

Performance:

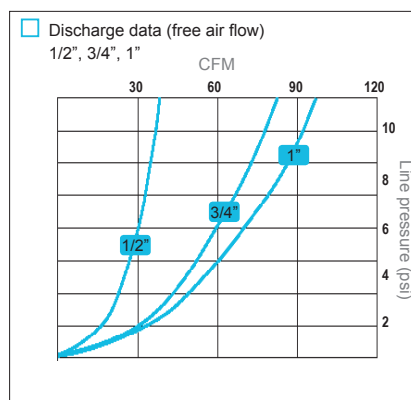
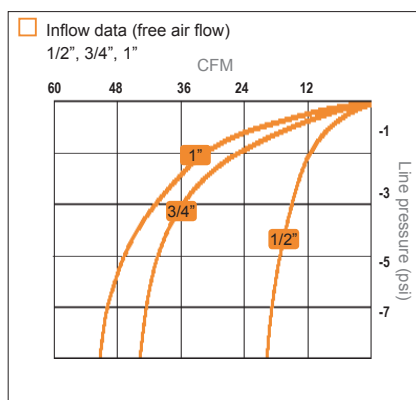
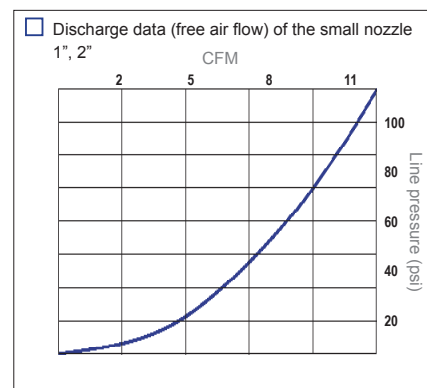
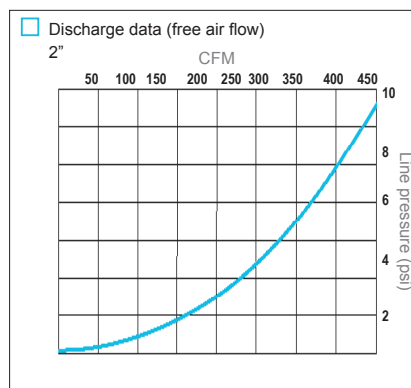
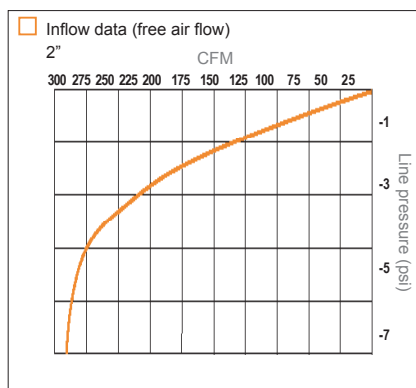



**Innovation**  
Innovation

**Expertise**  
Expertise

**Reliability**  
Reliability

Hundreds of companies in the industrial, civil engineering, municipal and agricultural sectors around the world have chosen our innovative and field-proven technologies. Since our establishment we strive to lead the valves market with continued innovation, uncompromising excellence and firm commitment to our customers, consulting and supporting them through all stages of a project and overcoming challenges in R&D, design, implementation, and maintenance.



Distributed by:  MIFAB

MIFAB, Inc., 1321 West 119th Street,  
Chicago Illinois 60643-5109, USA  
Toll Free: 1-800-465-2736, Fax: 1-773-341-3049  
Canada Toll Free: 1-800-387-3880  
www.beecoacv.com sales@mifab.com

LIT-065