

**Specification:** MIFAB® Series 4x2-1, 4 1/8" reinforced round solid nickel bronze strainer and shank, with a free area of 5 IN<sup>2</sup> and a load rating of 2000 lbs.

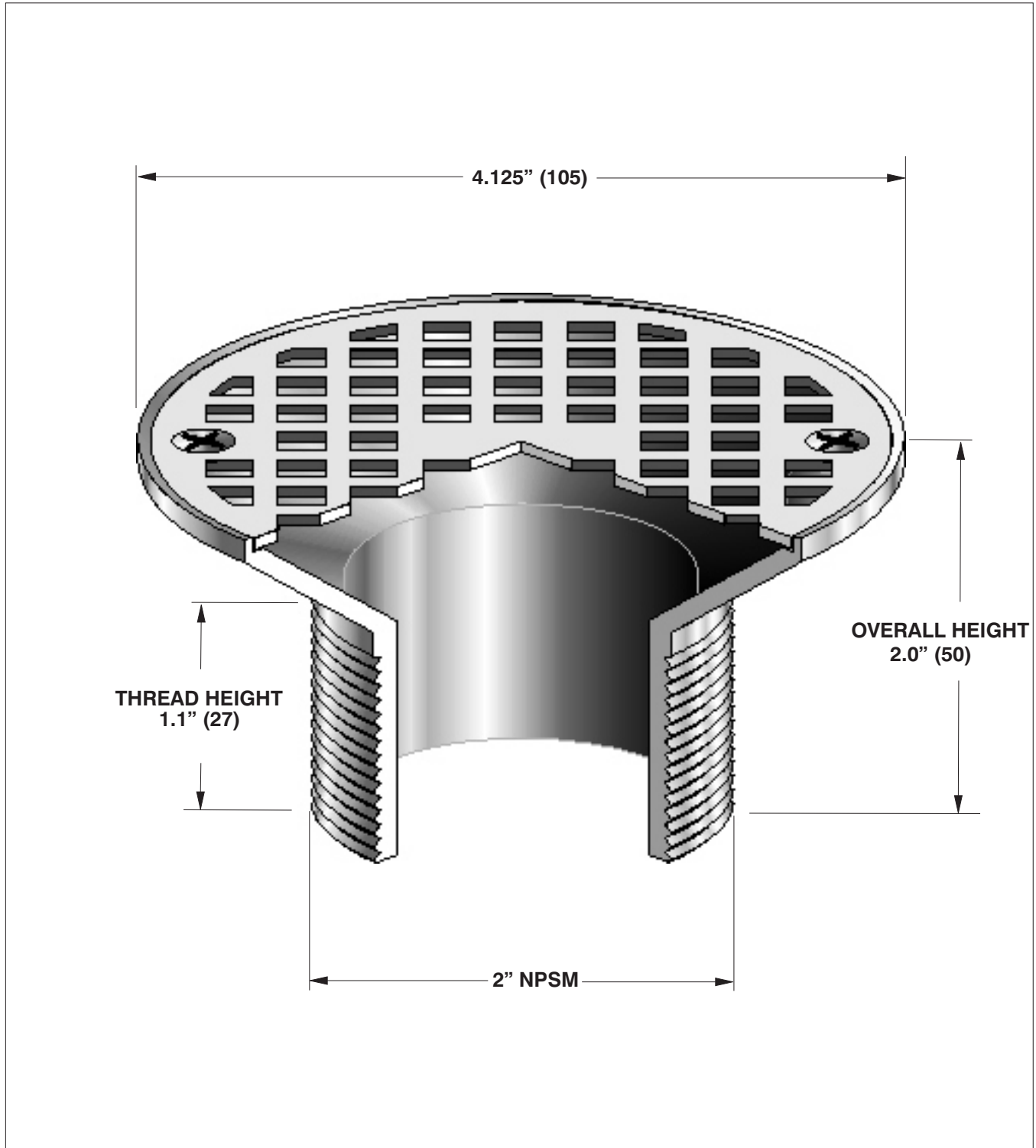

**OPTIONAL VARIATIONS: SUFFIX**

- |   |     |
|---|-----|
| <input type="checkbox"/> Polished           | -2  |
| <input type="checkbox"/> Chrome Plated      | -49 |
| <input type="checkbox"/> Vandal proof grate | -6  |

Job Name: _____	Page No: _____
Section No: _____	Contractor: _____
Schedule No: _____	Purchase Order No: _____