

Location: \_\_\_\_\_



**T1500-PG-FSPC**

**6" WIDE, 39.40" LONG, STAINLESS STEEL,  
PERFORATED, HEAVY DUTY (LOAD CLASS C) GRATE**

**Specification:** MIFAB T1500-PG-FSPC, heavy duty, (Load Class C), stainless steel (Type 304), reinforced perforated grate is 4.80" wide x 39.40" long, weighing 2.95 lbs. per linear foot. The grate has 1/4" diameter holes and has a free open area of 29.76 square inches and is ADA compliant and H-20 load rated. The grate is secured to the body with a four point self-locking (snap in) system.

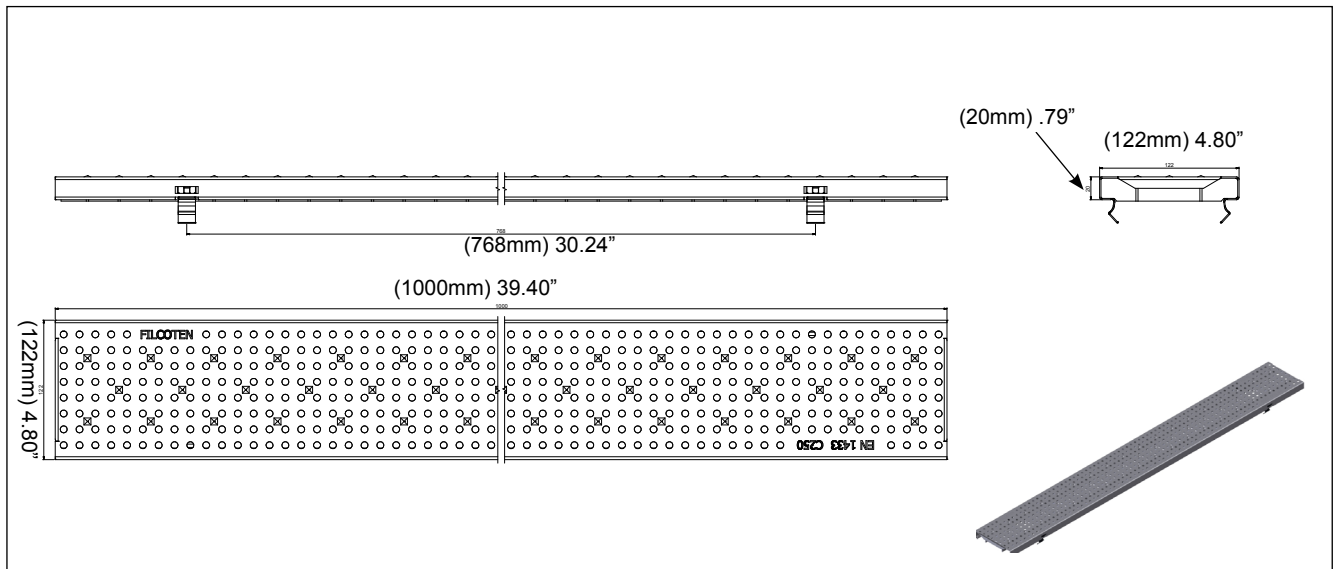
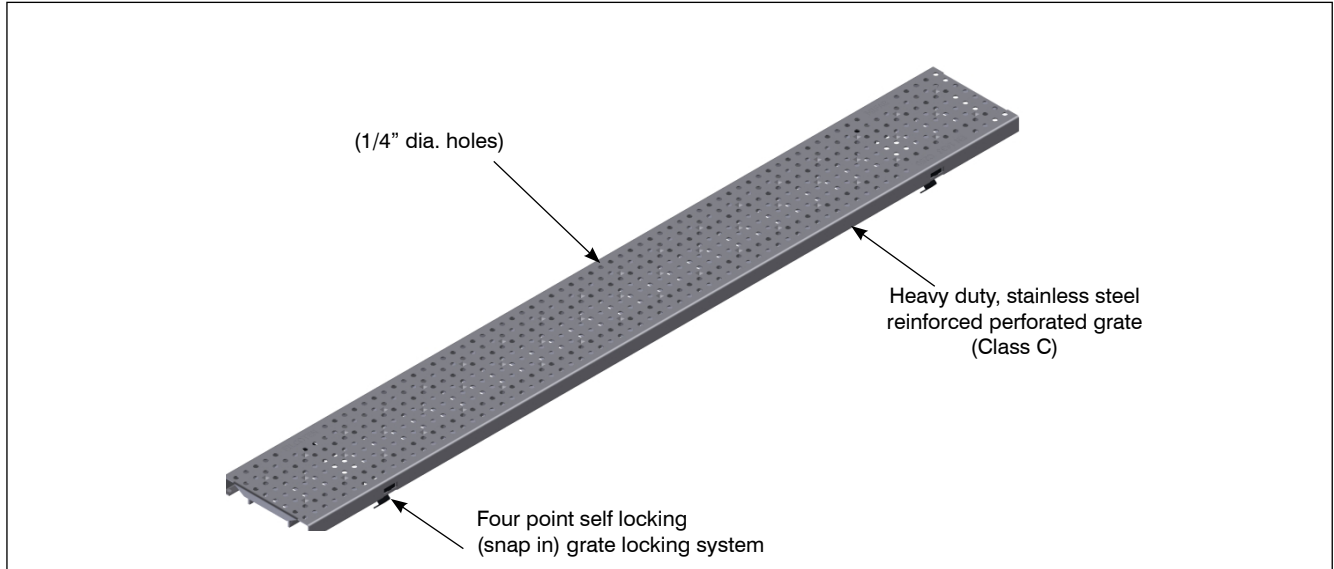

Load Class C- Heavy Duty, DIN 19580, 56,000 lbs. 1.162 psi. For commercial pneumatic tire traffic patterns and tractor trailers.

Job Name: \_\_\_\_\_  
Section No: \_\_\_\_\_  
Schedule No: \_\_\_\_\_

Page No: \_\_\_\_\_  
Contract: \_\_\_\_\_  
Purchase Order No: \_\_\_\_\_

MIFAB reserves the right to make changes in material and design without formal notice or obligation.

USA: 1-800-465-2736 [www.mifab.com](http://www.mifab.com) CAN: 1-800-387-3880