

Location: _____



T1100-F

6" Wide, Frame and Grate System

Specification: MIFAB® Series T1100-F, 6" wide, frame and grate system available in 20" long increments with a heavy duty angle iron frame assembly (1" x 1" x ¼") for all grates to secure to and finished with an acid resistant powder epoxy coating. Each 20" long section has two 1" x 3" long anchor tabs / leveling devices for securing into the surrounding concrete. Complete with MIFAB's standard ductile iron grate (T1400-PG-4). Load Class E.

Function: Used in airports, car washes, malls, parking lots, factories and any other facilities that require areas of surface drainage. The standard heavy duty angle iron frame provides for maximum load bearing capability. No body is provided as the channel is typically formed into the concrete by the installer. An infinite number of sections can be assembled together to serve any requirement.

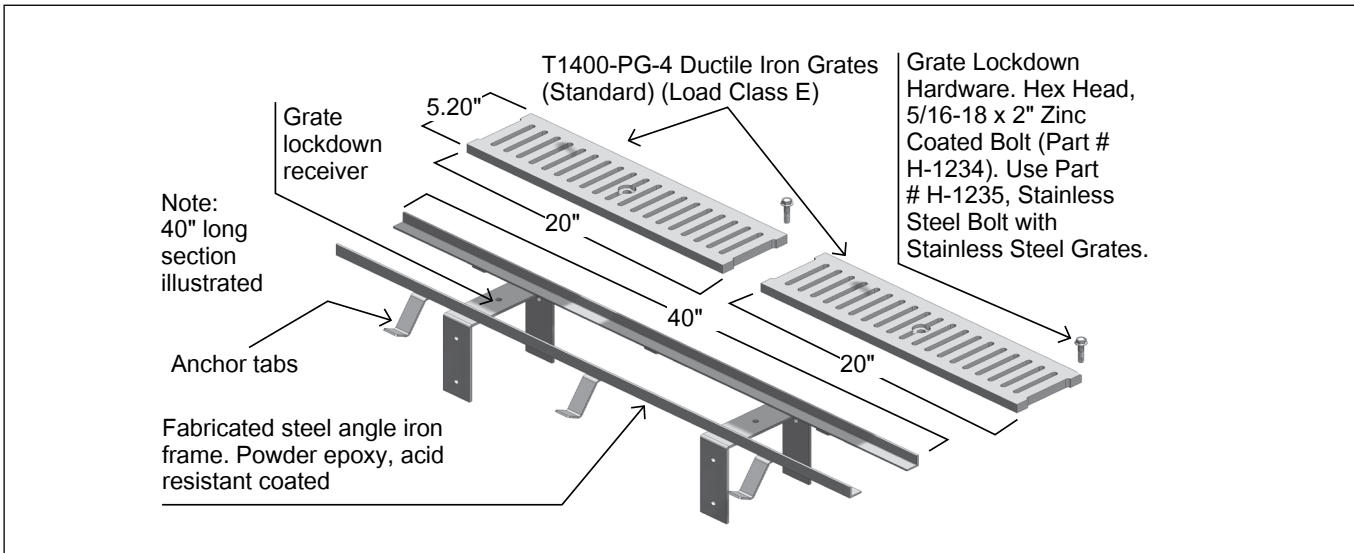
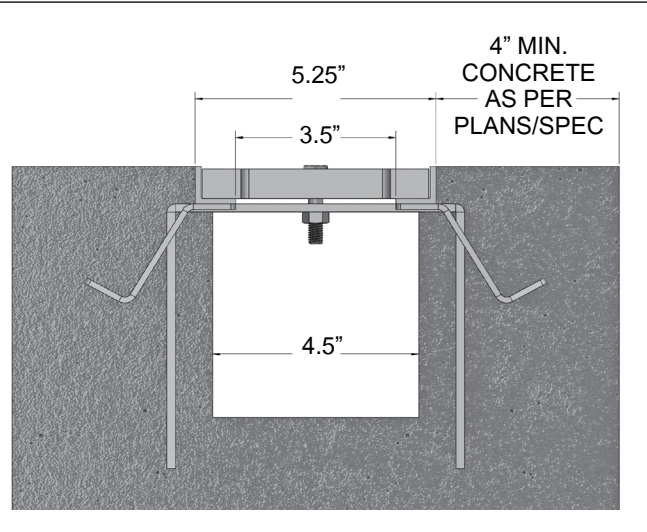

SUFFIX	OPTIONAL VARIATIONS
-3	Stainless steel grate and frame veneer – per section
-6	Vandal proof – per grate (H-1110)

SUFFIX	OPTIONAL VARIATIONS
-11	All acid resistant epoxy coated – per section
-13	All galvanized – per section

Job Name: _____ Page No: _____
 Section No: _____ Contractor: _____
 Schedule No: _____ Purchase Order No: _____