

Location: _____



BCV

BALL CHECK VALVE

Purpose: Ball check valves contain a ball that sits freely above the seat, which has only one through hole. When the pressure above the seat exceeds that above the ball, liquid is allowed to flow through the valve. But once the pressure above the ball exceeds the pressure below the seat, the ball returns to rest in the seat, forming a seal that prevents backflow.

Design: Check valves are mechanical valves that permit gases and liquids to flow in only one direction, preventing process flow from reversing. They are classified as one-way directional valves. Fluid flow in the desired direction opens the valve, while backflow forces the valve closed. The mechanics of check valve operation are not complicated.

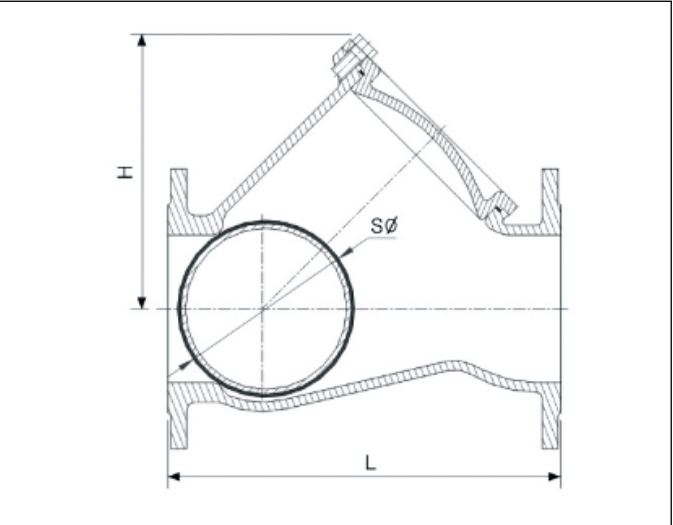

Part Name	Material	EN Spec.	ASTM Spec.
Body	Ductile Iron	EN-JS1050	A536-65-45-12
Cover	Ductile Iron	EN-JS1050	A536-65-45-12
Ball	Aluminum NBR/EPDM Coated	EN1706 AC-42100	ANSI H35.1(M) 356.0
Gasket	NBR/EPDM	Commercial	Commercial

Model No.	Size	L	H	SØ
BCV1.50	1 1/2"	7.09"	3.94"	1.96"
BCV2.00	2"	7.87"	4.92"	2.48"
BCV2.50	2 1/2"	9.45"	5.51"	3.15"
BCV3.00	3"	10.24"	6.69"	3.78"
BCV4.00	4"	11.81"	7.87"	4.92"
BCV5.00	5"	13.78"	8.86"	5.91"
BCV6.00	6"	15.75"	10.43"	7.09"
BCV8.00	8"	19.69"	13.98"	9.84"
BCV10.00	10"	23.62"	16.54"	12.60"
BCV12.00	12"	27.56"	18.90"	14.57"
BCV14.00	14"	31.50"	22.83"	17.32"

CALIFORNIA PROPOSITION 65 WARNING: This product contains chemicals known to the State of California to cause cancer and birth defects or other reproductive harm.

Job Name: _____ Page No: _____

Section No: _____ Contractor: _____

Schedule No: _____ Purchase Order No: _____