

Location: _____



BIG-L

Big Max® – HDPE Lint Interceptors

Specification: MIFAB® Series BIG-____-L HDPE rotational molded lint interceptor with liquid holding capacity of ____ (indicate) gallons. Unit shall include: dual strainer baffles with 3/8" Dia. holes, 1/2" apart, deep seal trap covered by lid, adjustable lid system, sample port access and 4" no hub inlet and outlet connections. Steel encased composite lid provides a water / gas tight seal and has a minimum of 20,000 lbs. load capacity. The lid is designed in accordance with the loading requirements of AASHTO H20.

Function: Used in laundries and maintenance facilities to receive waste water that contains lint. The lint interceptor will filter out lint and sediment from the fixture waste line before entering the pipe system to reduce clogging and improve performance. Typically installed either on or into the floor. Narrow width permits access through doorways and down stairwells. High Density Polyethylene construction ensures a lightweight installation process (two people can move and install it). Regular maintenance is required to keep the interceptor functioning. All Big Max interceptors can withstand a temperature of up to and including 180 degrees Fahrenheit.

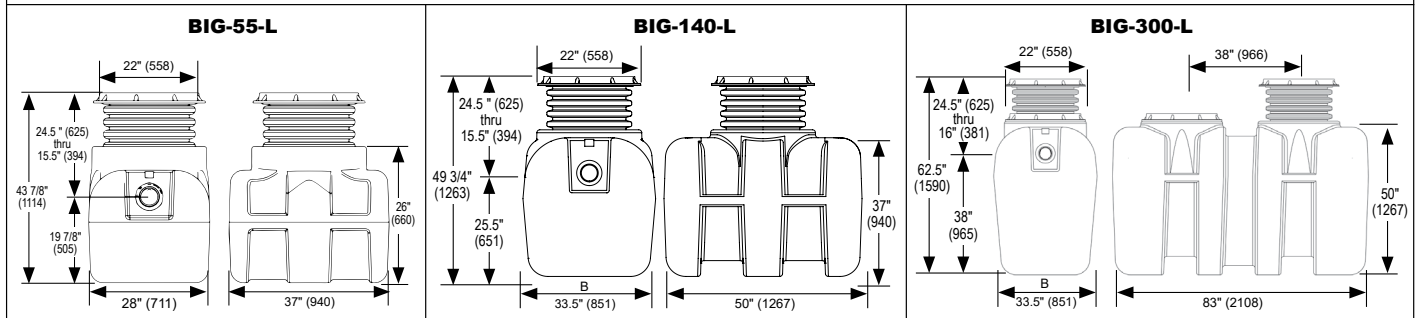
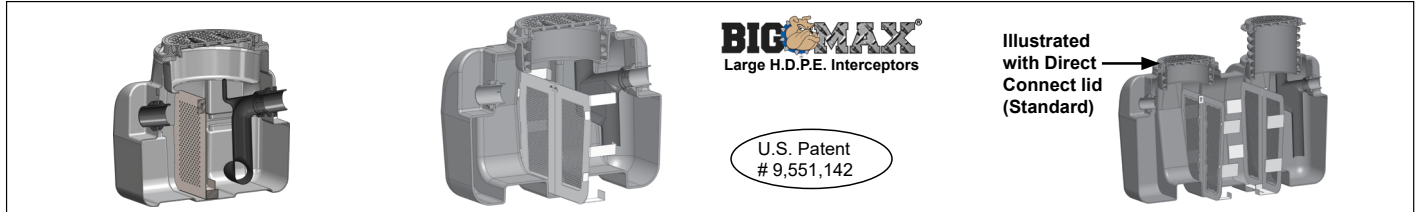

Model No.	Number of Washing Machines	LIQUID CAP. (Gallons / Cu. Ft.)	SOLIDS CAP. (Gallons / Cu. Ft.)	B Width	Shipping Weight (Lbs.)
BIG-55-L	6	55 / 7.19	28 / 4	28.00"	92
BIG-140-L	14	140 / 18.30	70 / 9	33.50"	165
BIG-300-L	30	300 / 39.21	150 / 20	33.50"	290

SUFFIX	OPTIONAL VARIATIONS	PART NO.
-AK	Anchor kit (set of two) for BIG-55-PL	BIG-500-AK-SET
-AK	Anchor kit (set of two) for BIG-140-L	BIG-750-AK-SET
-AK	Anchor kit (set of two) for BIG-300-L	BIG-1150-AK-SET
-C	Lid Extension - up to 44" high - for BIG-55-PL and BIG-140-PL	BIG-750-EXT-44
-C	Lid Extension - up to 72" high - for BIG-55-PL and BIG-140-PL	BIG-750-EXT-72
-C	Lid Extension - up to 94" high - for BIG-55-PL and BIG-140-PL	BIG-750-EXT-94
-C	Lid Extension - up to 44" high - for BIG-300-PL	BIG-1150-EXT-44 (2 pcs. Incl.)
-C	Lid Extension - up to 72" high - for BIG-300-PL	BIG-1150-EXT-72 (2 pcs. Incl.)
-C	Lid Extension - up to 94" high - for BIG-300-PL	BIG-1150-EXT-94 (2 pcs. Incl.)
-DI	Ductile iron lid and collar - for BIG-55-PL	XL-MI-G-0-PL4
-DI	Ductile iron lid and collar - for BIG-140-L	XL-MI-G-0-PL4
-DI	Ductile iron lid and collar - for BIG-300-L (2 pcs. Included)	XL-MI-G-0-PL4 (2 pcs. Included)
-F6	6" no hub inlet and outlet (2 pcs. Included) (flow rate of 700 GPM with 6" connections)	MI-G-PL-PF6
-FL-C	Membrane clamp kit for BIG-55-PL and BIG-140-L	XL-MI-G-PL-FLM
-FL-C	Membrane clamp kit for BIG-300-L (2 pcs. Included)	XL-MI-G-PL-FLM (2 pcs. Included)
-HF	250 GPM flow rate (with 4" connections)	-
-LHSI	No hub inlet on left hand side (not available with sediment bucket) (for Lil Max, Big Max, SuperMax)	MI-G-PL-PF4
-LHSO	No hub outlet on left hand side (not available with sediment bucket) (for Lil Max, Big Max, SuperMax)	MI-G-PL-PF4
-POK	Remote pump out kit	BIG-MAX-POK
-RHSI	No hub inlet on right hand side (not available with sediment bucket) (for Lil Max, Big Max, SuperMax)	MI-G-PL-PF4
-RHSO	No hub outlet on right hand side (not available with sediment bucket) (for Lil Max, Big Max, SuperMax)	MI-G-PL-PF4
-RPO	4" Remote pump outlet connections on top of interceptor - specify location and number required	BIG-MAX-RPO
-SP	External sampling port - inline, high connections	BIG-SP
-SP-L	External sampling port - inline, low connections	BIG-SP-L
-SP-OF	External sampling port - offset	BIG-SP-OF
-T	Female threaded connections (2 pcs. Included)	MI-G-PL-PF4T

CALIFORNIA PROPOSITION 65 WARNING. This product contains chemicals known to the State of California to cause cancer and birth defects or other reproductive harm.

Job Name: _____ Page No: _____

Section No: _____ Contractor: _____

Schedule No: _____ Purchase Order No: _____