

Location: _____



R1200-JD-G8H-AI

PLANTING AREA DRAIN

Specification: MIFAB® Series R1200-JD-M-G8H-AI* (specify size) lacquered cast iron large planting area drain with anchor flange, cast iron water proofing membrane clamp ring, stainless steel ballast guard with secured cover, auxiliary inlet, and lifting handle.

Function: Used to drain water that accumulates on green roof applications. The perforated stainless steel ballast guard prevents vines from entering the drain line.

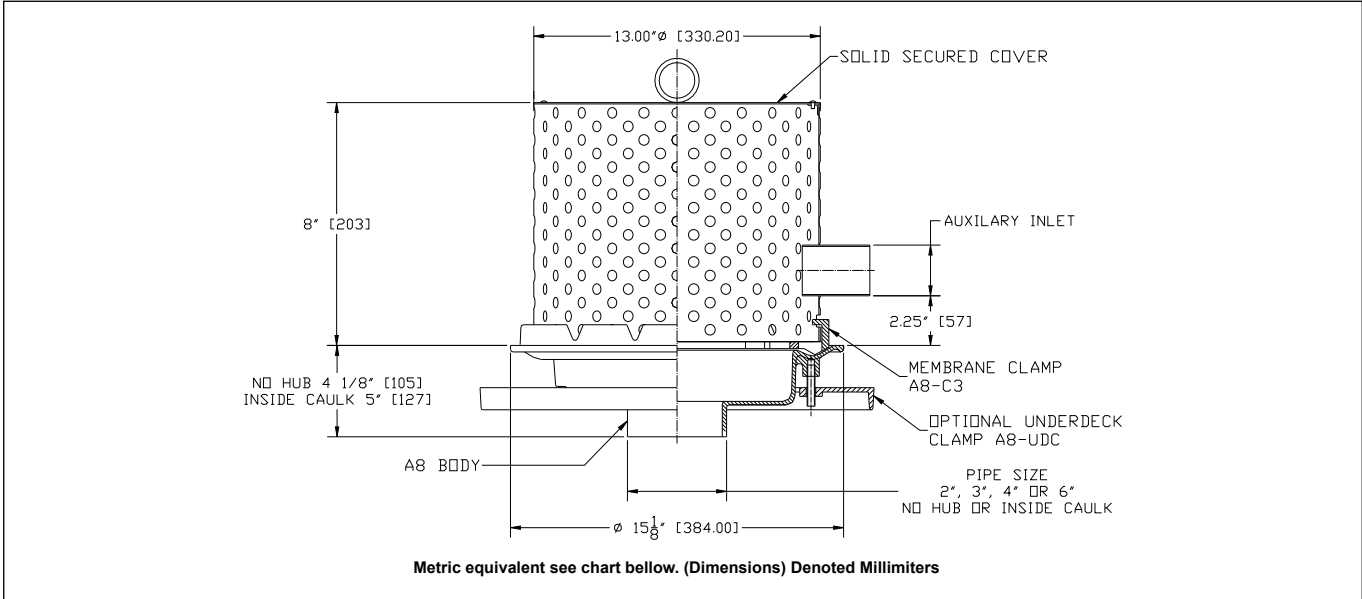

PIPE SIZE	A8 BODY HEIGHT	
	NO HUB (STANDARD)	INSIDE CAULK (X)
2" (51)	4 1/8" (104)	5.05" (127)
3" (76)	4 1/8" (104)	5.05" (127)
4" (102)	4 1/8" (104)	5.05" (127)
5" (127)	4 1/8" (104)	5.05" (127)
6" (152)	4 1/8" (104)	5.05" (127)

Suffix	Description
-11	Acid resistant epoxy coated body, membrane clamp & dome
-12A	Galvanized body and membrane clamp
-13	Galvanized body, membrane clamp and dome
-28	Stainless steel body (Type 304)
-45	3" no hub auxiliary inlet (on ballast guard)
-46	4" no hub auxiliary inlet (on ballast guard)
-47	Custom ballast guard height (per 1" over the standard 8")
-B	Sump receiver (A8-BP)
-BA	Buy America Act compliant product
-C	Secondary clamp (A8-C3)
-E	Adjustable extension
-EG	Galvanized adjustable extension
-PA	Pennsylvania Steel Act compliant product
-R	2" external water dam (A8-WD)
-V	Fixed extension, (2",3",4") (A8-V2, A8-V3, A8-V4)
-VG	Galvanized fixed extension, (2",3",4")
-W	Adjustable water dam (5" high x 4" diameter) (W-31)
-W-1	Water proofing flange (A8-W-1)
-W2	2" internal water dam (2" high x 4" diameter) (A8-C3-W and W-31)
-W3	3" internal water dam (3" high x 4" diameter) (A8-C3-W and W-31)
-W4	4" internal water dam (4" high x 4" diameter) (A8-C3-W and W-31)
X	Inside caulk outlet, (2", 3", 4", 5" or 6")
-Z	Extended wide flange on body (20" Dia. x 1/4 thick)

CALIFORNIA PROPOSITION 65 WARNING. This product contains chemicals known to the State of California to cause cancer and birth defects or other reproductive harm.

Job Name: _____ Page No: _____
 Section No: _____ Contractor: _____
 Schedule No: _____ Purchase Order No: _____