

Location: \_\_\_\_\_



**P6030**

**3" Wide, Stainless Steel Body and Grate System**

**SPECIFICATION:**

MIFAB® Series P6030, 3" wide, 16 gauge fabricated Type 304 stainless steel presloped trench drain (1/8" per foot) with slotted Load Class "A" Light duty stainless steel ADA compliant grates. Free area of 5.25 square inches per 1' section. Square bottom bodies have flanged ends to connect to each other with a neoprene rubber gasket in between. Bottom and end outlets are available in 1 1/2" or 2" no hub outlet connections (specify outlet size) and fabricated as part of the trench drain system. Also available with B, C, D and E load rated stainless steel grates and optional anchor flange (Suffix -FL).

**FUNCTION:**

Used in front of walk in coolers, barrier free showers and industrial, commercial, kitchen and other hygienic areas. Type 304 stainless steel construction provides for ease of cleaning, maintenance and sanitary installation. The inside of the body is manufactured without any overlapping material to ensure that bacteria does not have a place to grow. All grate openings are polished to a smooth finish.

**Note:** Every order of this product is a special / custom order fabrication. This product is non returnable and noncancellable.

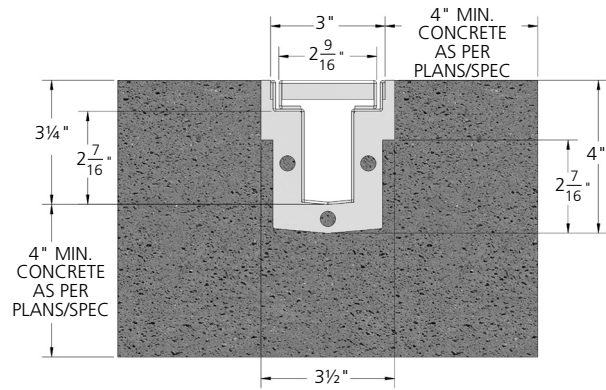

Specifying engineer is responsible for concrete encasement and reinforcing based upon application and local codes.

**Note:** The neoprene gasket used to connect long runs of trench drain bodies is not recommended for use with caustic or harsh chemicals. In these cases, it is recommended that the trench drain sections be welded on site.



(Illustrated with Optional -FL Anchor Flange)

The P6030-LCB is NSF certified with a load classification of Medium Duty.

MODEL NUMBER	DESCRIPTION
<b>P6030</b>	3" wide, Type 304 Stainless Steel Trench Drain Body and Grate System (Load Class "A", "Light Duty" ADA compliant grates).
<b>P6030-29</b>	3" wide, Type 316 Stainless Steel Trench Drain Body and Grate System (Load Class "A", "Light Duty" ADA compliant grates).

OPTIONAL VARIATIONS	DESCRIPTION
<b>-C</b>	Membrane Clamp
<b>-EO</b>	For a 1 1/2" end outlet add Suffix -150-EO to the model #. Eg. P6012-150-EO. For a 2" end outlet add Suffix -EO to the model #. Eg. P6012-EO.
<b>-FL</b>	Anchor Flange (Instead of Anchor Tabs)
<b>-LCB</b>	Load Class "B", Medium Duty Grate (2,000 - 4,999 lbs.)
<b>-LCC</b>	Load Class "C", Heavy Duty Grate (5,000 - 7,499 lbs.)
<b>-LCD</b>	Load Class "D", Extra Heavy Duty Grate (7,500 - 10,000 lbs.)
<b>-LCE</b>	Load Class "E", Special Duty Grate (over 10,000 lbs.)
<b>Length</b>	Specify the length that is required
<b>-LS</b>	Longitudinal Slotted Grate (ADA Compliant)

<b>-NS</b>	Slip Resistant Grate (Non slip grit finish)
<b>P</b>	Push on outlet
<b>-PG</b>	Perforated Grate (1/4" diameter holes)
<b>-PHP</b>	Perforated "Heel Proof Grate" (less than 1/4" diameter perforations)
<b>-SHP</b>	Slotted "Heel Proof" Grate (less than 1/4" wide slots)
<b>T</b>	Threaded outlet
<b>X</b>	Inside caulk outlet
<b>-5</b>	Sediment Bucket
<b>-6</b>	Vandal Resistant Grate
<b>-7MG</b>	MI-GARD trap seal protection device (available for 1-1/2", 2", 3", 3-1/2", 4" and 6" outlet connections)
<b>-90</b>	90 Degree Section

**Note:** A 2" No Hub bottom outlet is standard. For a 1 1/2" no hub bottom outlet connection, specify Suffix -150 after the model #. Eg. P6030-150.

CALIFORNIA PROPOSITION 65 WARNING. This product contains chemicals known to the State of California to cause cancer and birth defects or other reproductive harm.

Job Name: \_\_\_\_\_  
 Section No: \_\_\_\_\_  
 Schedule No: \_\_\_\_\_

Page No: \_\_\_\_\_  
 Contract: \_\_\_\_\_  
 Purchase Order No: \_\_\_\_\_