

Location: _____



MC-35

**HANGER PLATE AND EXPOSED ARM
LAVATORY CARRIER WITH THREE UPRIGHTS**

Specification: MIFAB® Series MC-35 hanger plate and exposed arm lavatory carrier with two universal, adjustable, top support plates and three white, lacquered, adjustable, cast iron exposed support arms assembled to lacquered cast iron invertible and adjustable arm supporting brackets. Complete with three lacquered 2" x 1" x 1/8" thick structural steel uprights with 3" x 4 1/2" welded steel feet and mounting hardware.

Function: Used to support extra wide heavy duty wall-hung lavatories such as scrub sinks that are independent of the wall. Heavy duty cast iron support arms provide extra support for the fixture. Designed for use in conjunction with the fixture hangar plate supplied by the fixture manufacturer.

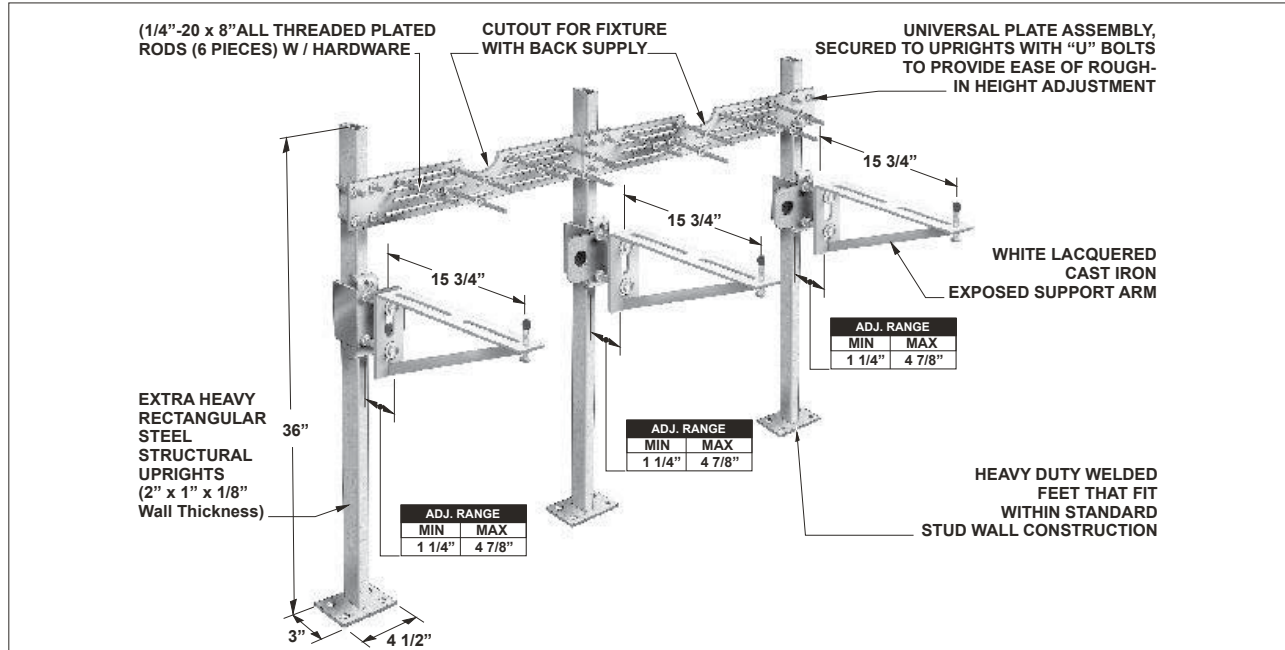

MC-35 Series Meets ANSI/ASME fixture carrier standard A112.6.1M-97

NOTE: FOOT SUPPORTS SHOULD BE SECURELY ANCHORED TO FLOOR WITH 1/2" (13) BOLTS AND ANCHORS BY OTHERS.

Note: Wall supported fixture mounting plates must be securely affixed (with suitable hardware by others) to a wall fully capable of bearing the weight of the plate and fixture.

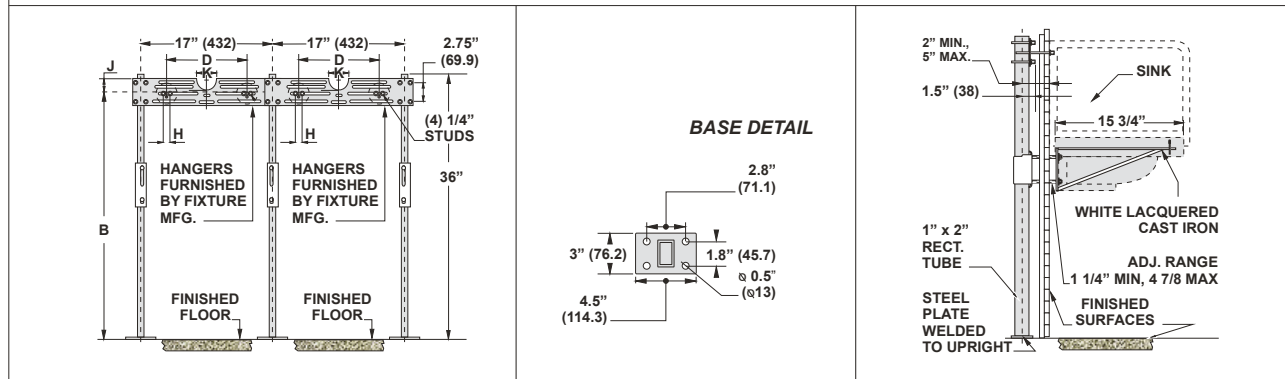

SUFFIX	OPTIONAL VARIATIONS
-A	Stud length over 8" (specify)
-BA	Buy American Act compliant product
-G	Wall support plate
-HDH	Heavy duty hanger
-PA	Pennsylvania Steel Act compliant product
-PFAB	Prefabricated carrier
-Z	Higher uprights (over 36")
-14	Vandal proof finish trim
-88	3/8" threaded eye bolts for cast iron lavs (H-1028)

CALIFORNIA PROPOSITION 65 WARNING. This product contains chemicals known to the State of California to cause cancer and birth defects or other reproductive harm.

Job Name: _____ Page No: _____
 Section No: _____ Contractor: _____
 Schedule No: _____ Purchase Order No: _____