

Location: _____



MC-33

HANGER PLATE CARRIER WITH THREE UPRIGHTS

Specification: MIFAB® Series MC-33 hanger plate carrier with two universal, adjustable, top support plates. Complete with three lacquered 2" x 1" x 1/8" thick structural steel uprights with 3" x 4 1/2" welded steel feet and mounting hardware.

Function: Used to support wall-hung fixtures such as urinals and water coolers that are independent of the wall. Designed for use in conjunction with the fixture hangar plate supplied by the fixture manufacturer.

UNIVERSAL PLATE ASSEMBLY, SECURED TO UPRIGHTS WITH "U" BOLTS TO PROVIDE EASE OF ROUGH-IN HEIGHT ADJUSTMENT

EXTRA HEAVY RECTANGULAR STEEL STRUCTURAL UPRIGHTS (2" x 1" x 1/8" Wall Thickness)

(1/4"-.20 x 8" ALL THREADED PLATED RODS (6 PIECES) W / HARDWARE

CUTOUT FOR FIXTURE WITH BACK SUPPLY

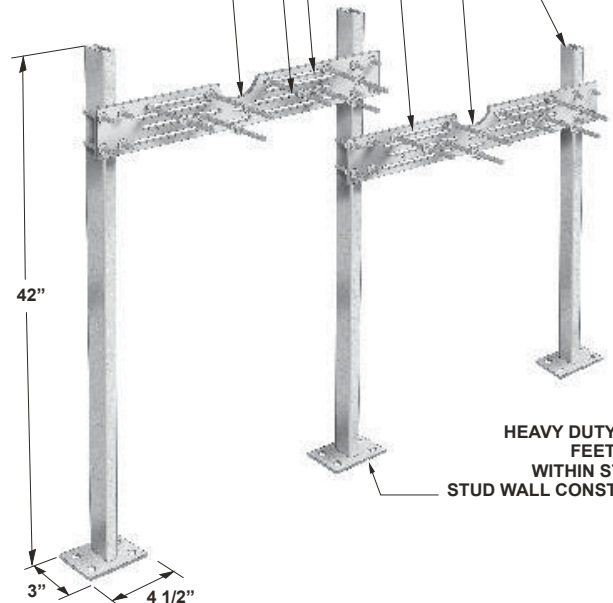

HEAVY DUTY WELDED FEET THAT FIT WITHIN STANDARD STUD WALL CONSTRUCTION

MC-33 Series Meets ANSI/ASME fixture carrier standard A112.6.1M-97

NOTE: FOOT SUPPORTS SHOULD BE SECURELY ANCHORED TO FLOOR WITH 1/2" (13) BOLTS AND ANCHORS BY OTHERS.

Note: See the various fixture dimensional rough-in guides on the www.mifab.com website.

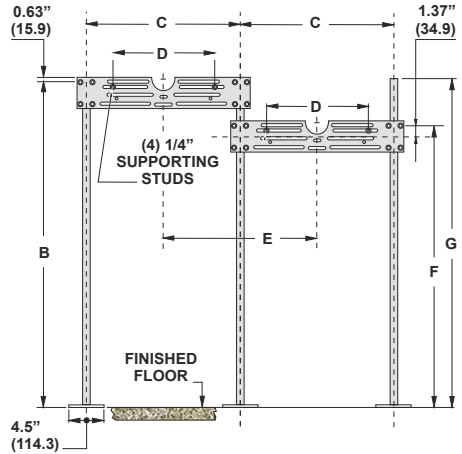

BASE DETAIL

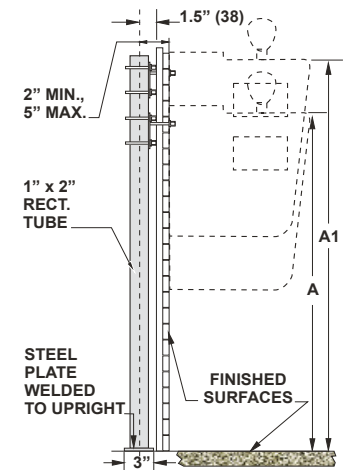
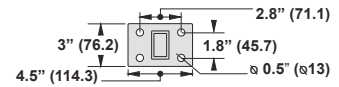

SUFFIX	OPTIONAL VARIATIONS
-A	Stud length over 8" (specify)
-BA	Buy American Act compliant product
-HDH	Heavy duty hanger
-PA	Pennsylvania Steel Act compliant product
-PFAB	Prefabricated carrier
-Z	Higher uprights (over 42")

CALIFORNIA PROPOSITION 65 WARNING. This product contains chemicals known to the State of California to cause cancer and birth defects or other reproductive harm.

Job Name: _____

Page No: _____

Section No: _____

Contractor: _____

Schedule No: _____

Purchase Order No: _____