

MIFAB®

HYDRANTS

HYDRANTS

DUAL SIZE INLET CONNECTION

MIFAB's hydrants are manufactured with a combination 3/4" female and 1" male threaded "inlet" connection for maximum installation flexibility.

VACUUM BREAKER

MIFAB's MHY-10, MHY-20 and MHY-60 hydrants are manufactured with a vandal resistant integral vacuum breaker that is tested and certified to the A.S.S.E. 1019-B Standard.

POLISHED CHROME FACE PLATE

MIFAB's wall hydrants are manufactured with a polished chrome plated face plate for a high quality and endearing appearance.

DRIP LIP

MIFAB's hydrant boxes are manufactured with a "drip lip". When the hydrant is turned off, and the hose is removed, the water that is within the hydrant will drain into the box and down the drip lip, away from the wall and onto the ground. This eliminates unsightly stains on the wall below the hydrant box which is typical with others.

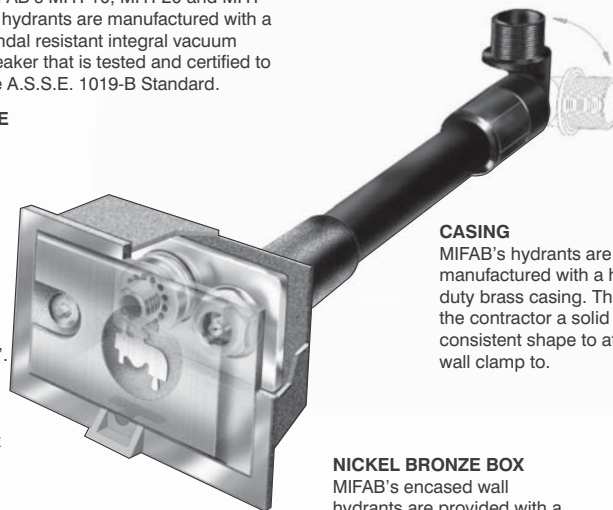

(MHY-20 ILLUSTRATED)

CASING

MIFAB's hydrants are manufactured with a heavy duty brass casing. This offers the contractor a solid and consistent shape to attach a wall clamp to.

NICKEL BRONZE BOX

MIFAB's encased wall hydrants are provided with a heavy duty cast nickel bronze box with hinged locking cover for maximum durability. Optional cast Stainless Steel box will not discolor due to oxidation. Specify suffix -3.