

MIFAB®

FIXTURE CARRIERS

STRUCTURAL FEET

The feet are heavy duty cast ductile iron and invertible. No distinction is necessary between right and left hand. Each foot wraps around the specially formed edge of the carrier body extending only 7/8" (22) beyond the faceplate. This wrap around design allows for better seating with a continuous adjustment slot that covers the full mounting range. Slots at the top and bottom provide additional means to install the feet. The 18" (460) height covers most mounting requirements for both standard and ADA water closets.

EXTENSION

The extension includes a test cap and N.P.T. (tapered) threads. It is made of ABS plastic. The standard length is 8" (200) long and covers a 1" (25) minimum to 6 1/4" (160) maximum range. After system testing, the extension is easily cut off to meet the installation requirements.

HARDWARE

The hardware is cadmium plated, with chrome plated MIFAB cap nuts.

FITTING GASKET

The gasket is elastomer and is designed with a raised bead to provide a positive watertight seal between the fitting and carrier body. It is held in place at the fitting opening, eliminating awkward handling when attaching the carrier body to the fitting.

CARRIER FACEPLATE

The faceplate is lacquered cast iron, heavy duty and invertible for use with siphon jet or blowout water closets. Breakaway tabs and elongated mounting slots accommodate the full range of standard and wheelchair roughing-in heights. It slides into the groove in the structural feet to form a rigid assembly.

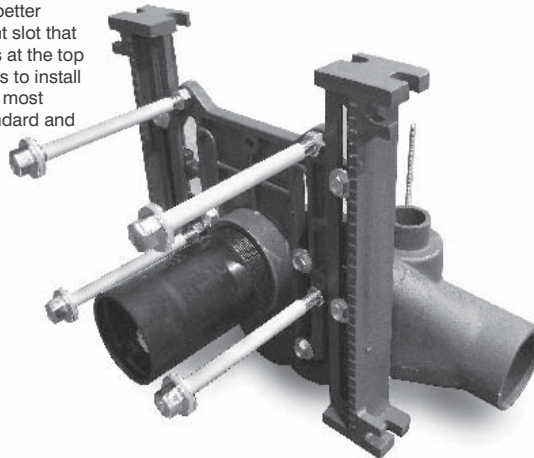

OPTIONAL ANCHOR FOOT

The anchor foot is heavy-duty lacquered cast iron, which provides three-point support. Adjustable threaded rod attaches the foot to the fitting. A single anchor bolt secures the foot to the floor. (Specify suffix -3)

FIXTURE CARRIERS