



Pressure Reducing Control Valve with Hydraulic Check Feature

Distributed by: MIFAB®

ACVxx-HF-PR-CV (Full Port: 1.50" – 2.50")

5/17

- Reduces a fluctuating higher inlet pressure to a constant lower outlet pressure
- Hydraulic Check Feature closes the valve upon pressure reversal
- Outlet setpoint is adjustable
- Valve will regulate near-zero flow without the use of special trim or low-flow bypass

Standard Components

- A – Main Valve
- B – Ball Valve
- C – Pressure Reducing Pilot
- D – Check Valve
- F – Self-Cleaning Strainer
- G – Pressure Gauge
- O – Orifice / Restrictor
- S – Adjustable Speed Control
- V – Air Vent

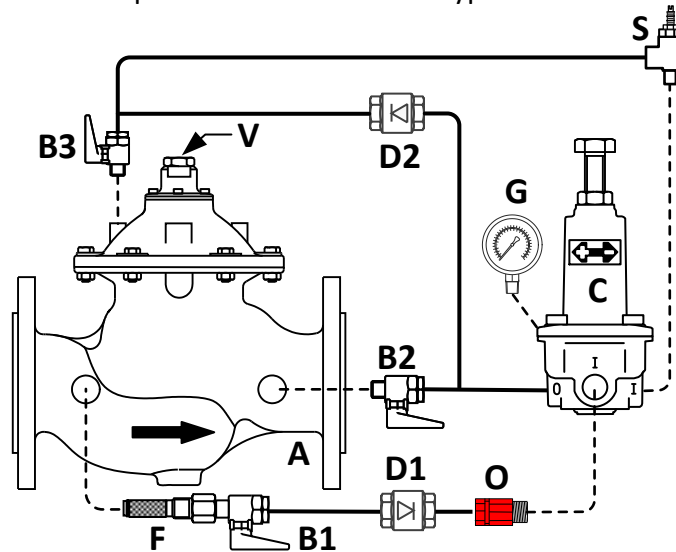

Operation

The BEECO Model “PR-CV” Pressure Reducing Control Valve with Hydraulic Check Feature is a pilot controlled diaphragm valve designed to reduce a fluctuating higher upstream pressure to a constant lower downstream pressure regardless of varying flow rates. It is controlled by Pressure Reducing Pilot (C) which internally senses downstream pressure, and allows fluid out of the main valve control chamber when downstream pressure is below the adjustable setting, and fluid to fill the main valve control chamber through Orifice / Restrictor (O) when downstream pressure is above the adjustable setting.

A decrease in downstream pressure below the adjustable setting of Pressure Reducing Pilot (C) causes the valve to modulate toward an open position, raising downstream pressure. An increase in downstream pressure above the adjustable setting causes the valve to modulate toward a closed position, lowering downstream pressure.

The downstream pressure setting can be changed by turning the Adjusting Screw of Pressure Reducing Pilot (C) clockwise (in) to increase or counterclockwise (out) to decrease the setting. Pressure Gauge (G) indicates downstream pressure setting. Speed of valve operation/response is controlled by Speed Control (S).

If downstream pressure rises above upstream pressure the valve closes, preventing reverse flow.

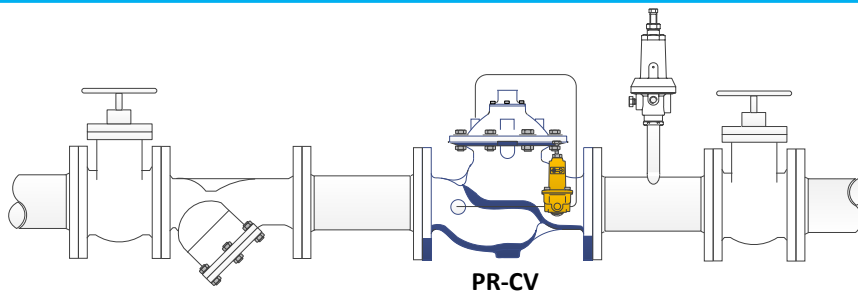

The Model PR-CV reduces high pressure from near zero to the maximum flow rate without the need for an additional Low-Flow Bypass. If the system is subjected to potentially static downstream conditions, a Pressure Relief Valve (½” or larger) is recommended for additional system protection.

Pressure Reducing Control Valve w/ Hydraulic Check Feature

ACVxx-HF-PR-CV (Full Port)
ACVxx-PR-CV (Reduced Port)

Materials	Main Valve	Pilot Control System
Body & Cover	Ductile Iron ASTM A-536	Control Pilot(s) Brass w/ Stainless Steel Seat
Coating	Fusion Bonded Epoxy (RAL 5010)	Tubing Fiber Reinforced Nylon SAE J844 (std) Copper (optional) Stainless Steel (optional)
Seat & Throttling Guide	304 Stainless Steel	Fittings Brass (std) Stainless Steel (optional)
Elastomers	Nylon Reinforced EPDM	Strainer Self Cleaning (1.50"-2.50") Removable Self-Cleaning (3"-12")
Diaphragm Washers	304 Stainless Steel (1.50"-6") Epoxy Coated Steel (8"-12")	Ball Valves Standard (all sizes)
Stem, Spring & Nut	Stainless Steel	
External Fasteners	Stainless Steel (1.50"-8") Zinc Plated Steel (10"-12")	

Main Valve Components and Options

Optional Valve Position Indicator (-I)

A Valve Position Indicator can be added to any new or existing Control Valve. The Position Indicator installs in the center of the Main Valve Cover/Bonnet. The stainless steel Indicating Shaft attaches to the Main Valve Stem by a floating ball & socket connection. An adjustable trip collar is included for the addition of an optional Limit Switch.

Optional Cavitation Control Trim Kit (-F)

For use when the pressure drop through a standard valve exceeds recommended safe operating conditions. The multi-port design allows damaging cavitation to occur inside the calibrated stainless steel cylinder, isolating the valve body and internal components from potential damage.

Repair Kits

Repair Kits are available for each size Main Valve, and contain all Rubber Components necessary to rebuild the valve. Repair Kits are also available for each Control Pilot.

No special tools are required to Service or Repair the Main Valve or Control Pilots.

Pilot Control System

The valve has two tapped ports on the Inlet and Outlet. The Pilot Control System is typically assembled using the ports on the "Right Hand" side of the Control Valve. Depending on valve size and/or function(s), the ports on the left-hand side of the valve may also be used. Adequate room should be provided to allow Service Technicians access the Pilot Control System for Start-Up and Maintenance Operations. The Pilot Control System can be installed on the left-hand side of the valve if specified "Left Hand Installation". Consult proper valve Schematic before field-changing from Right-Hand to Left-Hand to insure proper port connections.

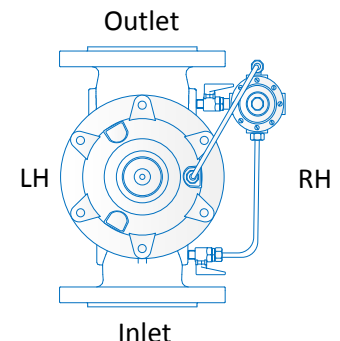
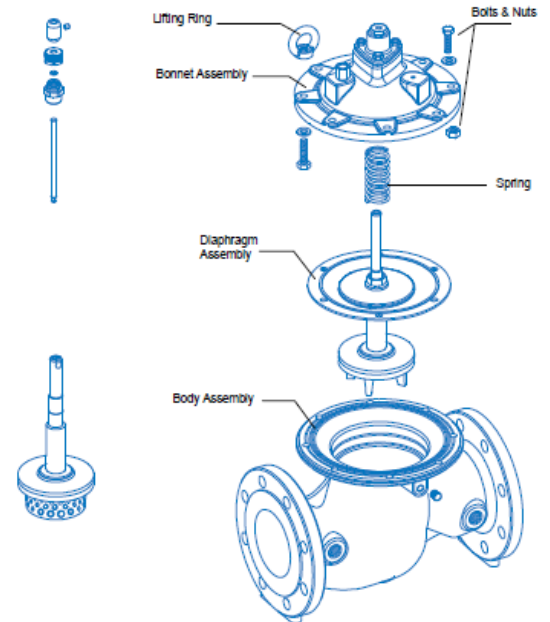

Pressure Reducing Control Valve w/ Hydraulic Check Feature

ACVxx-HF-PR-CV (Full Port)
ACVxx-HF-HP-PR-CV (Full Port)

(xx = Size)

Specification

The Pressure Reducing Control Valve with Hydraulic Check Feature shall be a pilot controlled diaphragm valve designed to automatically reduce a fluctuating higher upstream pressure to a constant lower downstream pressure regardless of varying flow rates. If downstream pressure rises above upstream pressure the valve shall close preventing reverse flow. The valve shall be capable of stable throttling from a minimum of <5 gpm to the rated capacity of the valve size without the use of an external low-flow bypass valve arrangement.

The valve Body and Cover shall be Ductile Iron ASTM A536 ([Globe, Angle](#)) Pattern, internally and externally epoxy lined and coated with ([Threaded, ANSI 150 Flanged, ANSI 300 Flanged, Grooved](#)) end connections. All control port connections shall be stainless steel to prevent corrosion and blockage. Direction of flow through shall be clearly indicated by a large highly visible flow arrow cast into the Valve Body. All external fasteners shall be stainless steel.

The Diaphragm shall be constructed of nylon reinforced EPDM, contour formed and molded to evenly contact the support surfaces of the Body and Cover without buckling or wrinkling when installed. The Disc and Diaphragm Assembly shall contain an EPDM Seal Disc. The valve Cover shall be equipped with an Air Release Vent to assist in start-up and troubleshooting procedures.

The Disc and Diaphragm Assembly must be separately top and bottom guided to avoid deflection and assure positive disc-to-seat contact. All Main Valve internals and throttling components shall be Stainless Steel.

The Pilot Control System shall contain a Flo-Clean Strainer, a Brass Pressure Reducing Pilot with pre-installed liquid filled pressure gauge, Color-Coded Fixed Orifice Restriction, Adjustable Valve Speed Control, (2) rubber seated spring loaded Poppet Check Valves, Type B Nylon Core Fiber Reinforced and Jacketed Control Tubing conforming with SAEJ844 / DOT FMVSS 49CFR 571.106 with Brass Fittings, and Isolation Ball Valves on all Body and Cover port connections.

The Main Valve with Pilot Control System installed shall be factory tested hydrostatically to 160% of the maximum working pressure and functionally tested to assure proper valve performance prior to shipment.

The valve will be sized as shown on the plans and associated valve schedules, and shall be BEECO Model [ACV-HF-PR-CV](#) or [ACV-HF-HP-PR-CV \(Full Port\)](#) Pressure Reducing Control Valve with Hydraulic Check Feature.

Other BEECO Pressure Reducing Control Valves

PR	Pressure Reducing Control Valve
PR-EL	Pressure Reducing Control Valve w/ Electric On-Off Feature
PR-PS	Pressure Reducing Control Valve w/ Pressure Sustaining Feature
PR-Q	Pressure Reducing Control Valve w/ Quick-Closing Feature