

Location: _____



AP

AIRPORT SUPPORT SYSTEM

Specification:

Dimensions: 2" High x 5" Wide x Length (Base Length)

Material

Base - 100% recycled rubber, UV resistant

Maximum Load: 500 lbs.



**Environmentally Friendly
made from
100% recycled tires**

Function: The AP Series is designed to provide support for all electrical and HVAC equipment. Grooved recessed tray prevents movement and dampens vibration. Allows water passage; prevents growth of moss and mold. Lightweight. Consult roofing manufacturer or engineer for roof loading.



Consult with roofing consultant for allowable loads.

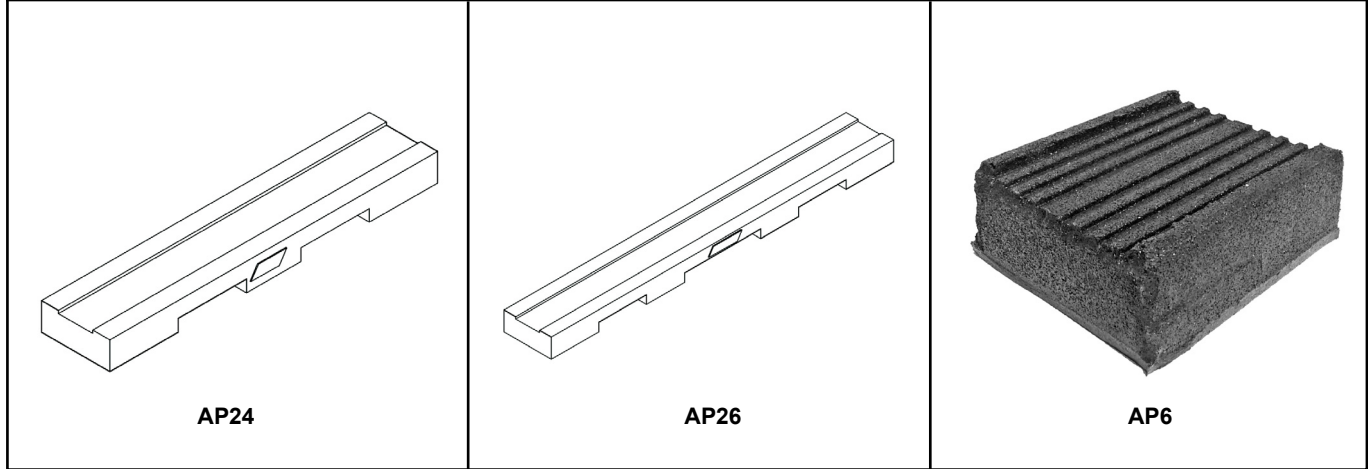
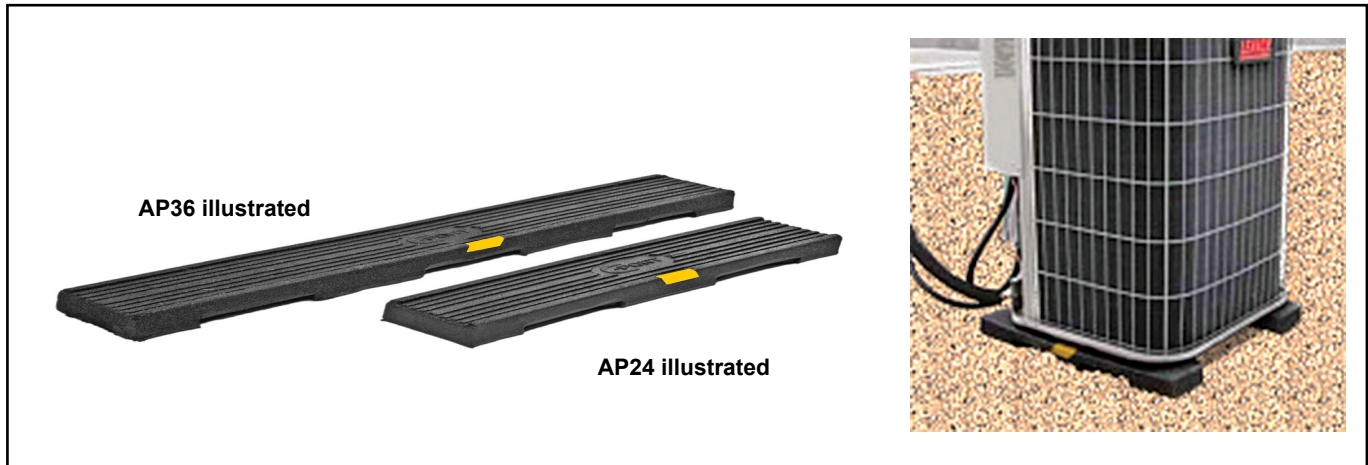

MODEL NO.	HEIGHT (H)	WIDTH (W)	LENGTH (W)	WEIGHT
AP6	2" (51)	5" (127)	5 1/2" (140)	2.20 lbs.
AP24	2" (51)	5" (127)	24" (610)	7.12 lbs.
AP36	2" (51)	5" (127)	36" (914)	12.14 lbs.

CALIFORNIA PROPOSITION 65 WARNING. This product contains chemicals known to the State of California to cause cancer and birth defects or other reproductive harm.

Job Name: _____ Page No: _____
 Section No: _____ Contractor: _____
 Schedule No: _____ Purchase Order No: _____

MIFAB® reserves the right to make changes in material and design without formal notice and obligation.

USA: 1-800-465-2736 www.mifab.com CAN: 1-800-387-3880